

FURUNO

OPERATOR'S MANUAL

VOYAGE DATA RECORDER
SIMPLIFIED VOYAGE DATA RECORDER

VR-3000

MODEL VR-3000S



FURUNO ELECTRIC CO., LTD.

NISHINOMIYA, JAPAN

SAFETY INSTRUCTIONS

WARNING



ELECTRICAL SHOCK HAZARD
Do not open the equipment.

Only qualified personnel should work inside the equipment.

Do not disassemble or modify the equipment.

Fire, electrical shock or serious injury can result.

Immediately turn off the power (BATTERY, DC and AC switches in that order) at the DCU and also turn off the power at the ship's mains switchboard if water leaks into the equipment or the equipment is emitting smoke or fire.

Continued use can cause fatal damage to the equipment.

WARNING

Keep heater away from equipment.

Heat can alter equipment shape and melt the power cord, which can cause fire or electrical shock.

Do not place liquid-filled containers near the equipment.

Fire or electrical shock can result if a liquid spills into the equipment.

Do not operate the equipment with wet hands.

Electrical shock can result.

Batteries should be recycled.
Contact FURUNO dealer.

CAUTION AT POWER-ON

On the power control panel in the DCU, confirm that the status display shows “- - -” and the NORMAL LED is lit after the power has been on for two minutes. If not, see Chapter 3.

Procedure for turning on power

1. Turn the AC breaker switch on.
2. Turn the DC breaker switch on if DC power is connected.
3. Turn the BATTERY breaker switch on.

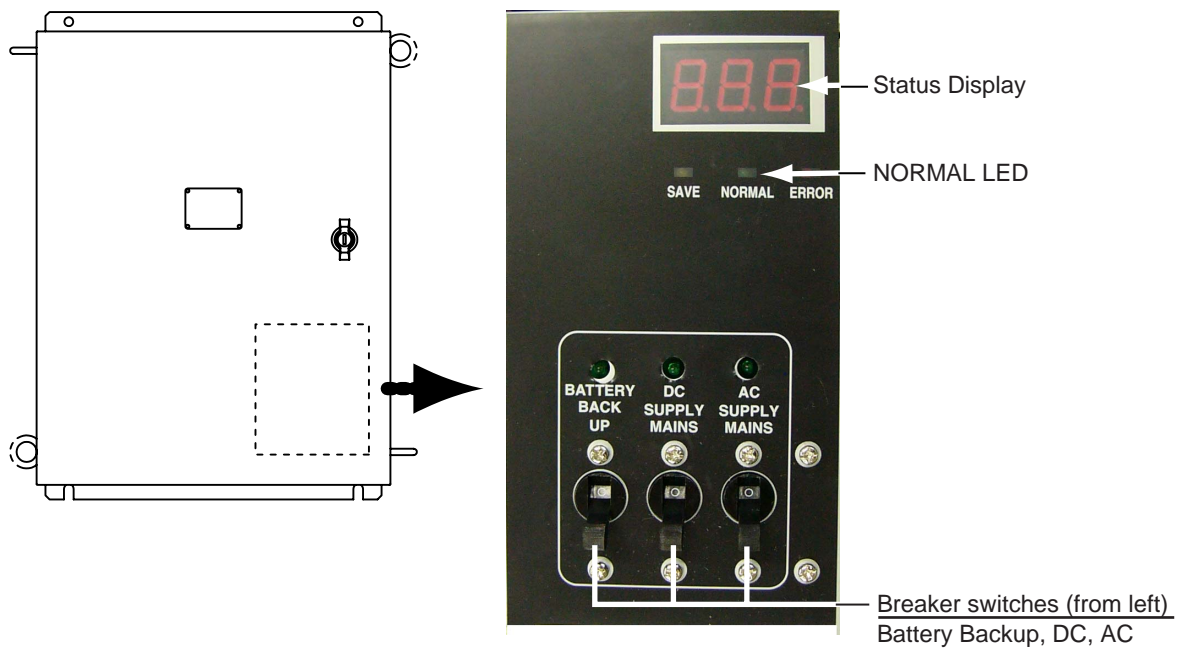

Power control panel/status display, inside the DCU

Error indication on Remote Alarm Panel (RAP)

If the ERROR LED (red) lights on the RAP, check the LEDs on the DCU.

CONTENTS

INTRODUCTION	iv
SYSTEM CONFIGURATION	v
1. OPERATION	1
1.1 Overview	1
1.2 Operating Procedure	5
1.3 Operation on Remote Alarm Panel	6
1.4 Copying of VDR Information	7
1.5 How to Remove DRU	7
2. MAINTENANCE	8
2.1 Routine Check	8
2.2 Replacement of Batteries	8
2.3 Replacing Acoustic Beacon	10
3. TROUBLESHOOTING	11
3.1 General Trouble Finding	11
3.2 Error Codes	12
4. LOCATION OF PARTS	16
4.1 Parts Location	16
4.2 Parts List	19
5. INTERFACE (IEC 61162-1, IEC-61162-2)	20
5.1 Data Sentences	20
5.2 Interface Circuits	33
SPECIFICATIONS	SP-1

INTRODUCTION

A Word to the Owner of the VR-3000, VR-3000S

Thank you for purchasing the FURUNO Voyage Data Recorder (VDR) VR-3000, Simplified Voyage Data Recorder (S-VDR) VR-3000S. We are confident you will discover why FURUNO has become synonymous with quality and reliability.

What is a VDR, S-VDR?

A VDR records various data and events encountered aboard ship. The purpose of the VDR is to help investigators locate the causes of marine incidents. There is no principle difference between a VDR and an S-VDR. The difference is the amount of information required to be recorded. The VDR is required to record more data than the S-VDR. Note that this manual refers to either the VDR or S-VDR as VDR.

The revised SOLAS Chapter V requires the installation of VDRs on passenger ships of 150 GT and above on all voyages and other ships of 3000 GT and above on international voyages and for newly built ships on and after 1 July, 2002.

The basic VR-3000/VR-3000S consists of a Data Collection Unit (DCU), a Data Recording Unit (DRU) and microphones to record bridge audio. The VR-3000 is also equipped with a Remote Junction Box (RJB), which is optional on the VR-3000S. The DCU contains the Data Processor Unit, interface modules and backup batteries. It collects data from sensors as required by the IMO and IEC standards. The DCU processes the incoming data and information in the order of occurrence while old data is overwritten with new data for storage in the DRU for a 12 h period. The batteries supply power to the DCU to record bridge audio for 2 h in case of a main ship's power failure.

The flash memory in the DRU stores the data coming from the DCU. All essential navigation and status data including bridge conversation, VHF communications, and radar images are recorded. The data can be retrieved by using playback software for investigation after an incident. The DRU components are embodied in the protective capsule. The capsule ensures survival and recovery of the recorded data after an incident. An acoustical pinger helps locate the DRU underwater.

Features

- Reliable and fast data exchange between DCU and DRU via a single IEEE1394 cable.
- Easy commissioning and maintenance by PC downloading/uploading
- 12-hour recording of normal sensor loading in standard memory
- UTC time tagged for system synchronization and easy data retrieval
- Choice of flash memory capacity in the data recording unit
- Removable hard disk (HD) for storage and retrieval of data
- Meets IMO A.861 (20), IEC 61996 and other relevant standards.

SYSTEM CONFIGURATION

VR-3000

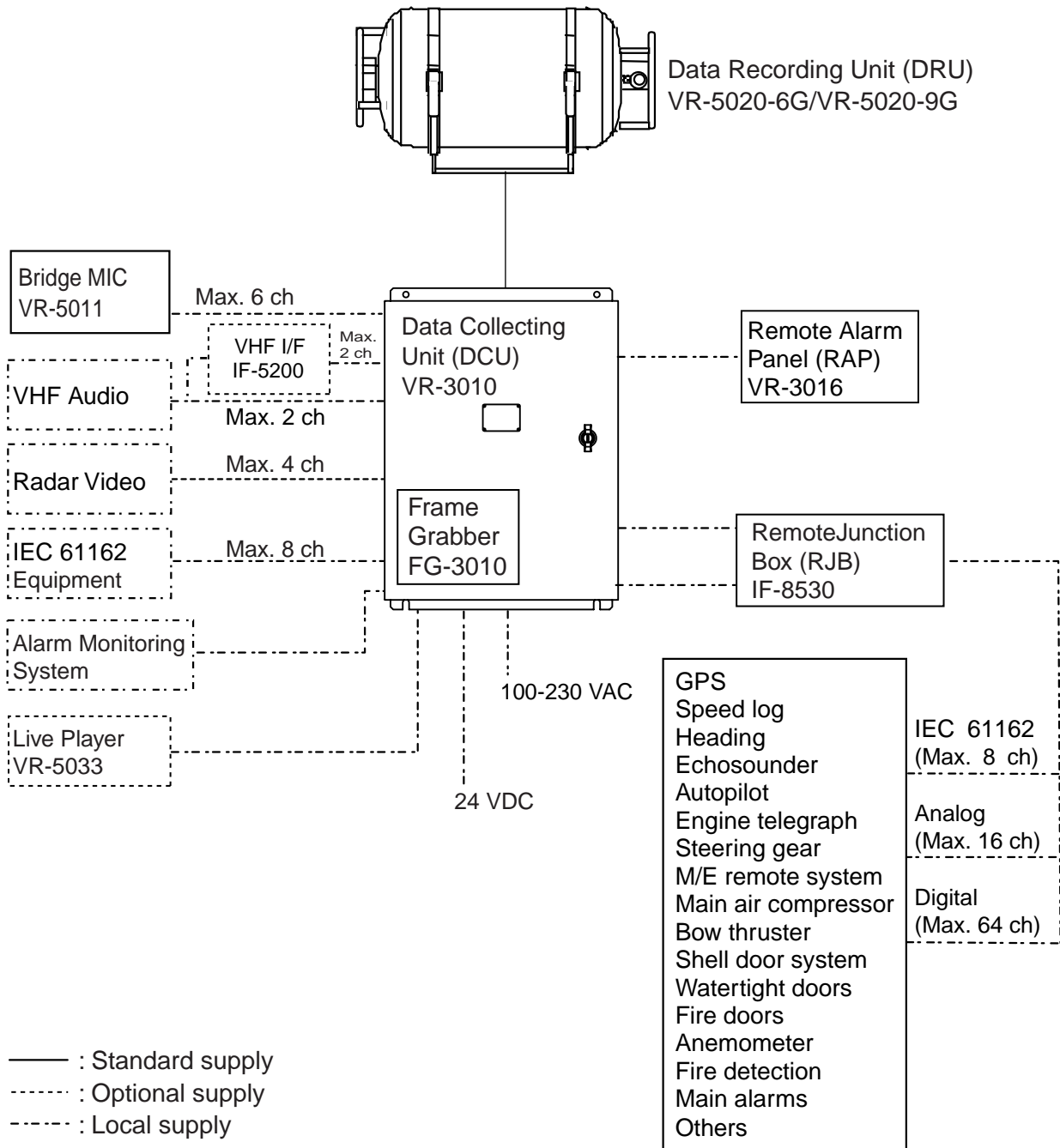

Environmental category

DCU	Protected from weather
DRU	Exposed to weather
RAP	Protected from weather
Microphone	Protected from weather
VHF I/F unit	Protected from weather
RJB	Protected from weather

VR-3000S

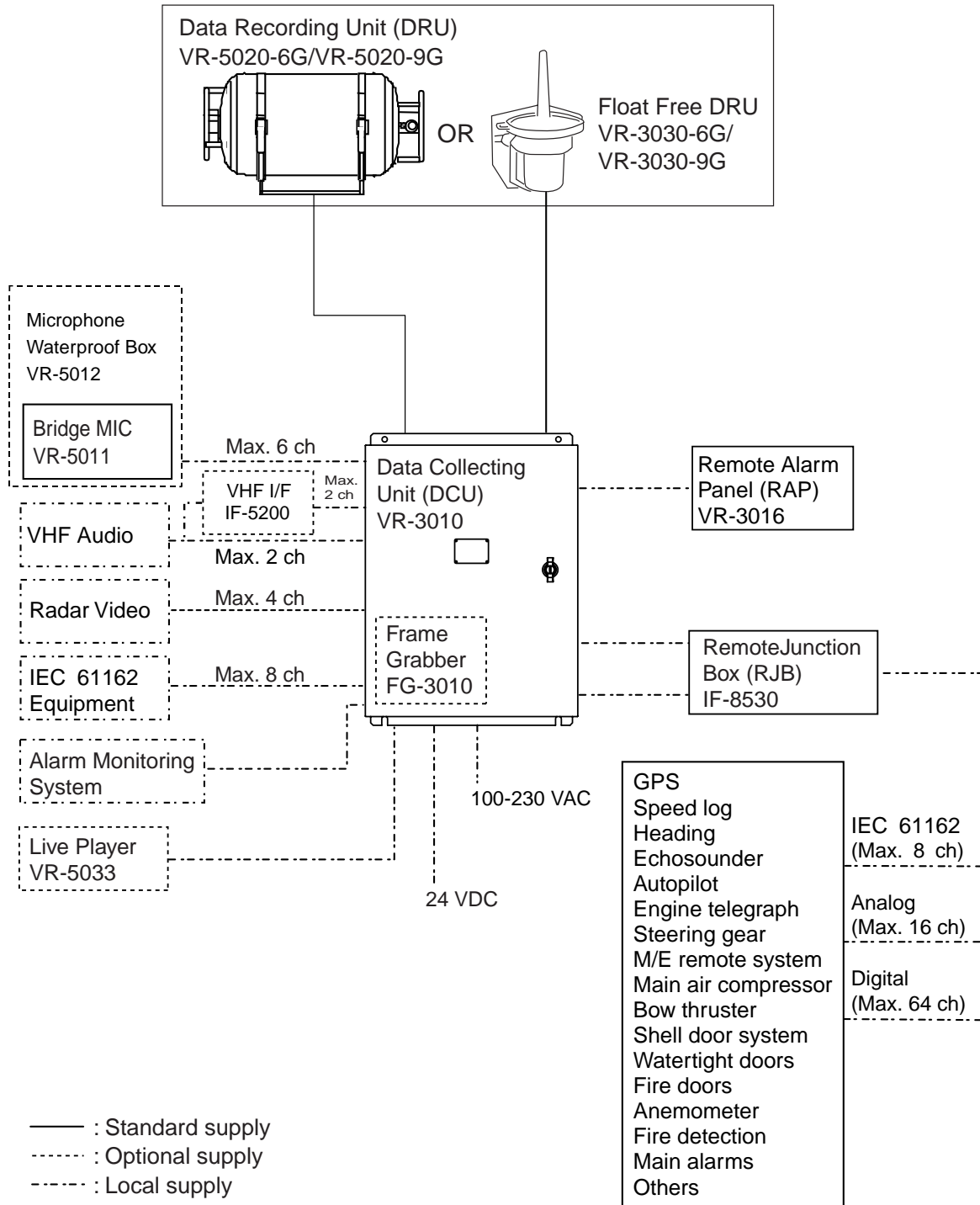

Environmental category

DCU	Protected from weather
DRU	Exposed to weather
RAP	Protected from weather
Microphone	Protected from weather
VHF I/F unit	Protected from weather
RJB	Protected from weather

1. OPERATION

1.1 Overview

The VR-3000/VR-3000S consists of Data Collecting Unit (DCU), Data Recording Unit (DRU), Remote Junction Box (optional supply with VR-3000S) and bridge microphone units. The VDR system continuously store data from the past 12 hours onto the Flash Memory in the capsule, erasing the oldest data stored as new data is recorded. The data to be recorded includes the following:

Parameters to be recorded	IEC 61162 formatter	Notes
Date and time	ZDA	
Ship's position and datum used	GNS and DTM	
Speed (water and/or ground)	VBW	
Heading (true)	HDT	
Heading (magnetic)	HDG	
AIS-VHF data-link message	VDM	
AIS-VHF data-link own-vessel message	VDO	
Depth (echo sounder)	DPT	
Alarms	ALR	No requirement for S-VDR to send alarm messages
Rudder order/response manual	RSA	
Rudder order/response automatic	HTC and HTD	
Engine order/response	RPM and XDR	
Hull openings, watertight doors	XDR	
Accelerations and hull stress	XDR, ALR	
Wind speed and direction	MWV	
VDR alarm output	\$VRALR	
Radar data		
Bridge audio		
VHF communication audio		

Power supply precaution

If ship's mains power source (100-230 VAC) and emergency source fail, the VR-3000S continues to record bridge audio for 2 h from backup batteries.

Continuity of storing data

The VDR should be provided with power to store data for 12 h on first-in, first-out basis. Recording is only terminated with a key under the following circumstances:

- a) During essential maintenance while the vessel is in port.
- b) When the vessel is laid-up.
- c) In case of emergency, when the HD is removed.

Data Recording Unit

The Data Recording Unit is housed in a highly visible protective capsule which can withstand a fire of 1100°C for 1 hour and deep-sea pressure of 6000 m.

The underwater acoustic beacon (pinger) on the capsule automatically transmits 10 ms pulses at 37.5 kHz for at least 30 days when it is submerged in water. The expected life of the beacon is 6 years. The DRU is connected to the Data Collecting Unit (DCU) with a non-halogen FireWire cable (IEEE1394).

Data Collecting Unit

The DCU mainly consists of Data Processor Unit, Power Control Panel and Junction Box. The DCU includes two 12 V backup batteries with a lifetime of approximately four years. The DCU collects the data from various sensors and radar and records them in the flash memory in the capsule (final recording medium).

Recording interval of data and audio is;

- Radar video signal: every 15 seconds
- Bridge and VHF audio: real time
- IEC sentences: when received
- Analog and digital data: every half seconds

Integrity

The recording integrity is ensured by continuous monitoring of power supply, record function, bit error rate, an microphone functionality. Visual alarm is generated for malfunction of any of these. Alarm status is also indicated by relay contacts.

Data items to be recorded

Date and time

Date and time is obtained from an external GPS navigator referenced to UTC. Time information is recorded at intervals of 1 s. Without data and time data, no data except audio signal is recorded.

Ship's position and datum used

Latitude, longitude and datum are obtained from a GPS navigator, Loran-C receiver or other EPFS or INS available on standard digital interface. The source of data is identifiable on playback.

Speed (water and/or ground)

Speed through the water (STW) or speed over the ground (SOG) is recorded at intervals of 1 s. The resolution is 0.1 kt. Transverse speed is also indicated when available on board.

Heading (true, magnetic)

Heading is recorded at intervals of 1 s to a resolution of 0.1°. The data is labeled G (gyrocompass), GPS, GLONASS, MAG. If heading information is not available in IEC 61162 format, an appropriate interface may be necessary.

AIS-VHF data-link message, AIS-VHF data-link own-vessel message

Where there is no commercial off-the-shelf interface available to obtain radar data then AIS target data shall be recorded as a source of information regarding other ships, otherwise AIS information may be recorded additionally as a beneficial secondary source of information on both other and own ship.

The VDM message shall be recorded in such a way that all target data available from the onboard AIS are acquired. If the VDO message is recorded, this shall be additional to the recording of individual sensor data.

Depth (echo sounder)

Depth under keel up to a resolution of 0.1 m as available on the ship is recorded.

Alarms

The status of all IMO mandatory alarms are recorded individually with ID number and time stamp. Audible alarms from the alarm units is stored simultaneously by the bridge audio microphones.

Rudder order/response

Rudder order and response angles are recorded up to a resolution of 1° as available on the ship. The rudder information is recorded. If more than one rudder is provided, the circuitry can be duplicated.

Engine order/response

The DCU obtains the engine order and response from the engine telegraph or direct engine control. The signal level is normally 0-10 V. The engine parameters with shaft revolution and ahead/astern indicators are recorded to a resolution of 1 rpm.

If a bow or stern thruster is fitted, the circuitry must be duplicated. If controllable pitch propellers are fitted, their order and response can be recorded.

Hull openings, watertight doors

Inputs digital or RS-422 serial can be connected individually. The data is received at intervals of 1 s and stored with time stamps. Serial data sentence XDR is received at a data rate of 1,200-9,600 baud.

Accelerations and hull stresses

The DCU obtains signals from appropriate hull stress and response monitoring devices. The inputs are recorded individually and stored with time stamps. Serial data sentence XDR is received at a data rate of 1,200-9,600 baud.

Wind speed and direction

The DCU obtains the signal from appropriate wind speed and direction sensor. The inputs are recorded individually and stored with time stamps. Serial data sentence XDR is received at a data rate of 1,200-9,600 baud.

VDR alarm output

There is no requirement for the S-VDR to send alarm messages. If, as an option, such messages are sent then the appropriate sentence format is ALR.

Radar data

Radar image including range rings, EBLs, VRMs, plotting symbols, radar maps, parts of SENC, voyage plan, and other essential navigational indications, is recorded in the DRU via the interface in the DCU which is connected to the buffered video output of the radar display unit. One complete picture frame is captured at intervals of 15 s.

The radar display complying with IEC 60936-1 should have a buffered output (VESA DMTS compatible) with resolutions between 640 x 480 and 1280 x 1024, and can be directly connected with the VDR. Scanning may be interlaced or non-interlaced.

Most type approved radars from different manufacturers can be interfaced with the DCU.

Bridge audio

Up to six microphones are supplied as standard to record conversation at conning station, radar display, chart table. If possible, the microphones should be positioned to capture the audio from the intercom, public address system, and audible alarms on the bridge. The microphones are labeled Mic1, Mic2, etc. Microphone captures conversation in the bridge, audio signals from equipment and sound from machinery. The microphone generates a test beep every 12 hours which is also recorded. The microphone picks up audio signals ranging from 150 to 6000 Hz.

Communications audio

A maximum of two VHF communications are recorded for both transmitted and received audio signals. Audio will be compressed by MP3 or similar technique. The VHF radio connections are labeled VHF1 and VHF2.

1.2 Operating Procedure

The VDR comes with a key to lock the DCU to protect against any unauthorized access. The key must be kept securely after installation.

1.2.1 Recording

On the power control panel in the DCU, turn on the AC SUPPLY MAINS , DC SUPPLY MAINS and BATTERY BACK-UP switches in this order. Confirm that the NORMAL LED on the power control panel and RAP lights. The VDR records data automatically in the DRU and HD memories.

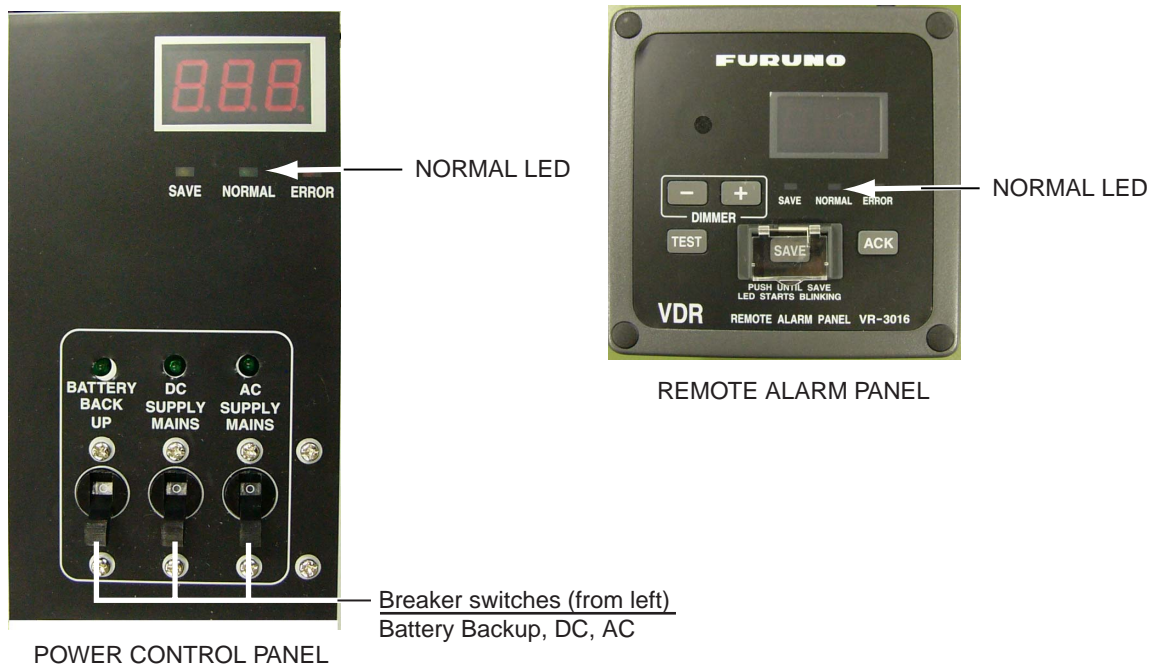

1.2.2 Stopping recording

Note that the recording is terminated only:

- During essential maintenance purposes while the vessel is in port.
- When the vessel is laid-up.

To stop recording, turn off the BATTERY BACK-UP, DC SUPPLY MAINS and AC SUPPLY MAINS switches in this order. **DO NOT turn off the system by the main breaker** while the BATTERY switch is on. If this is done, the system operates on the batteries. The system stops after running on batteries for 2 hours.

1.3 Operation on Remote Alarm Panel

No power switch is provided on the Remote Alarm Panel. It is turned on and off by the power switch on the DCU. To silence the buzzer, press the **ACK** button. When the ERROR LED (red) on the Remote Alarm Panel is on, identify the error by checking code number on the Power Control Panel in the DCU, referring to Chapter 3. The buttons on the Remote Alarm Panel work as described in the figure below.

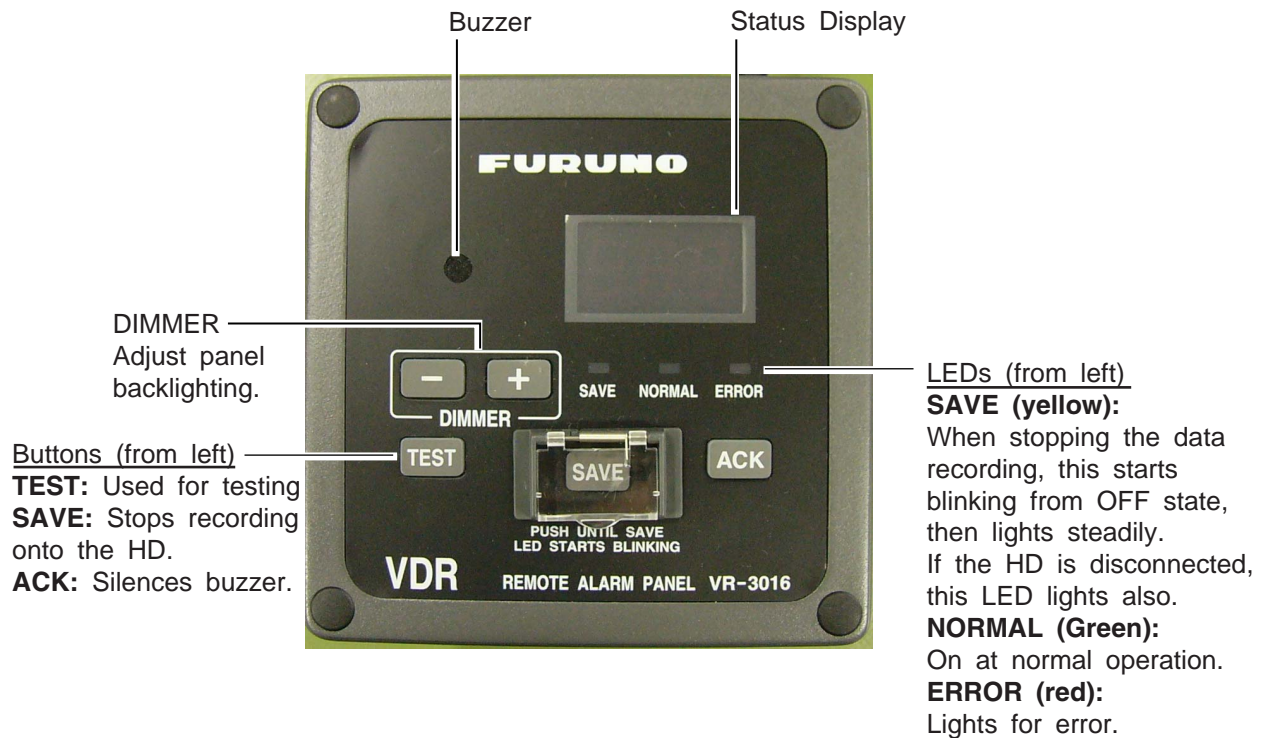

Remote Alarm Panel

Note: Every time the radar connected to the VDR is turned off, the alarm sounds. Press the ACK button to silence the alarm.

*: If the HD is removed after stopping data recording, data can not be written to the same HD. To use the same HD, consult a FURUNO serviceman.

1.4 Copying of VDR Information

VDR information is copied automatically into the removable hard disk (HD) for 12 hours and is then automatically over-written with new data. Bring the HD with you after an incident if possible.

To remove the HD, do the following:

1. Press the **SAVE** button (long press) on the RAP (Remote Alarm Panel). The yellow LED starts blinking, showing that recording is being terminated.
2. Wait until the LED lights steadily..
3. Pull the knob on the HD door to open the door.
4. Disconnect the FireWire cable.
5. Remove the HD.

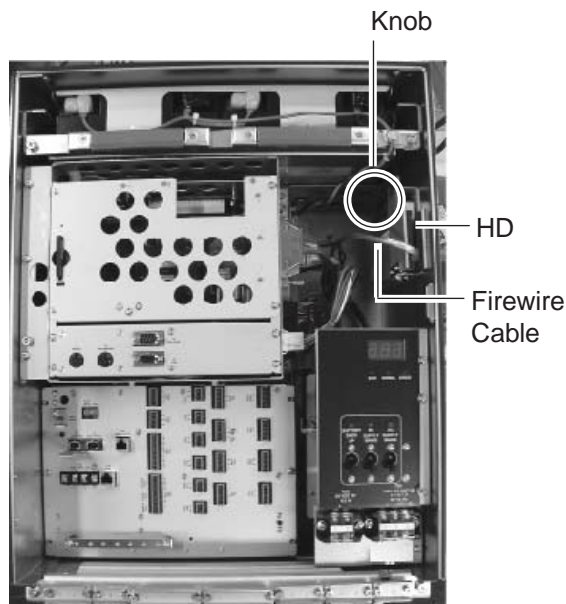

DCU, showing location of HD

1.5 How to Remove DRU

To remove the DRU from the bracket (cradle) do the following:

1. Loosen the hand-tightened cap.
2. Pull the DRU cable straight out.
(The cable may be cut after an incident.)
3. Remove two snap pins and then two hinge pins.
4. Lift the release levers.

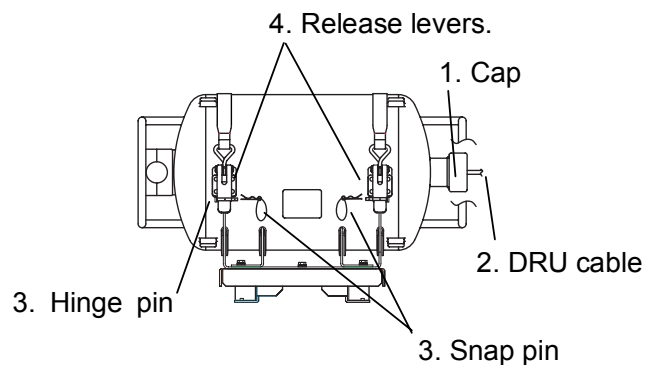

DRU

2. MAINTENANCE

Periodic checks and maintenance are important for proper operation of any electronic systems. This chapter contains maintenance instructions to be followed to obtain optimum performance and the longest possible life of the equipment. This chapter, except for 2.1 Routine check, is provided for qualified personnel.

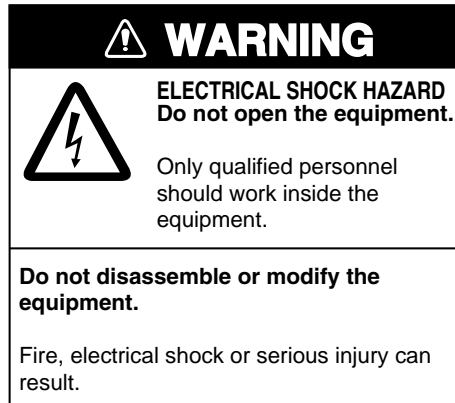

2.1 Routine Check

Periodically, carry out the following checks.

- 1) Examine the cables for signs of damage, such as chafing, cuts or nicks.
- 2) Check that all connections are tight.

2.2 Replacement of Batteries

Every four years, the back-up batteries (2 pcs.) in the DCU must be replaced with new ones (Type: NPH16-12T, Code no.: 000-157-809) by a qualified service engineer. Note that the batteries should be recycled. Contact a FURUNO dealer for further details.

Observe the following precautions with the batteries:

- Do not attempt to dismantle the battery. If accidental skin/eye contact is made with the battery fluid, wash the affected area/part immediately with liberal amounts of clean fresh water and seek IMMEDIATE medical attention.
- DO NOT INCINERATE batteries as they are liable to rupture if placed into a fire. Batteries that have reached the end of their service life must be disposed in accordance with appropriate regulations.
- Do not attempt to dismantle the battery. If accidental skin/eye contact is made with the battery fluid, wash the affected area/part immediately with liberal amounts of clean fresh water and seek IMMEDIATE medical attention.
- Touching electrically conductive parts might result in an electric shock. Be sure to wear rubber gloves before inspection or maintenance work.
- Mixing batteries with different capacity, different ages and different manufactures is liable to cause damage to the battery itself and/or the associated equipment.
- To obtain maximum life, batteries should never be shorted in a discharge state.

To replace the batteries, do the following:

1. Power off the DCU.
2. Open the DCU cover with the key.
3. Unfasten J3 connector from the PDU Board (24P0083)
4. Unfasten two screws securing the batteries.
5. Use the handles on the batteries to remove them from the DCU.
6. Disconnect four connectors.
7. Replace batteries.
8. Lock the DCU.

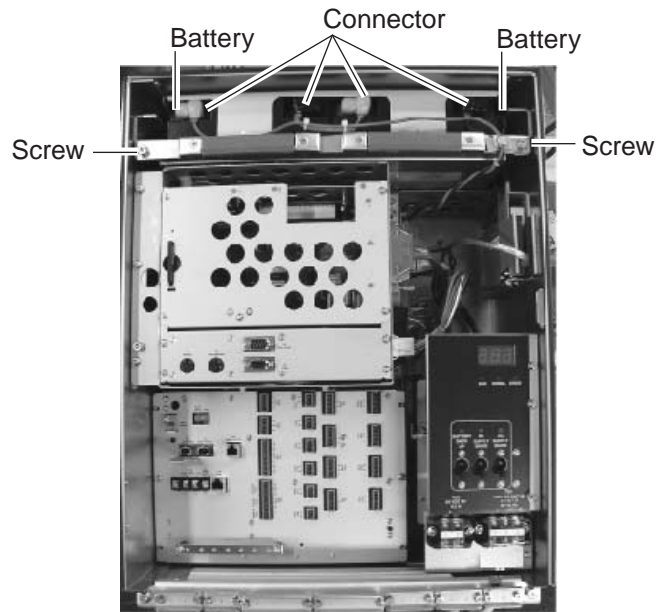

DCU, inside view

2.3 Replacing Acoustic Beacon

The underwater acoustic beacon has a built-in battery with approx 6 year lifetime. The beacon must be replaced with new one (Type: DK-120, Code no. 000-148-648) by a qualified service engineer before validity date marked on the beacon.

Necessary tool: M5 Allen wrench

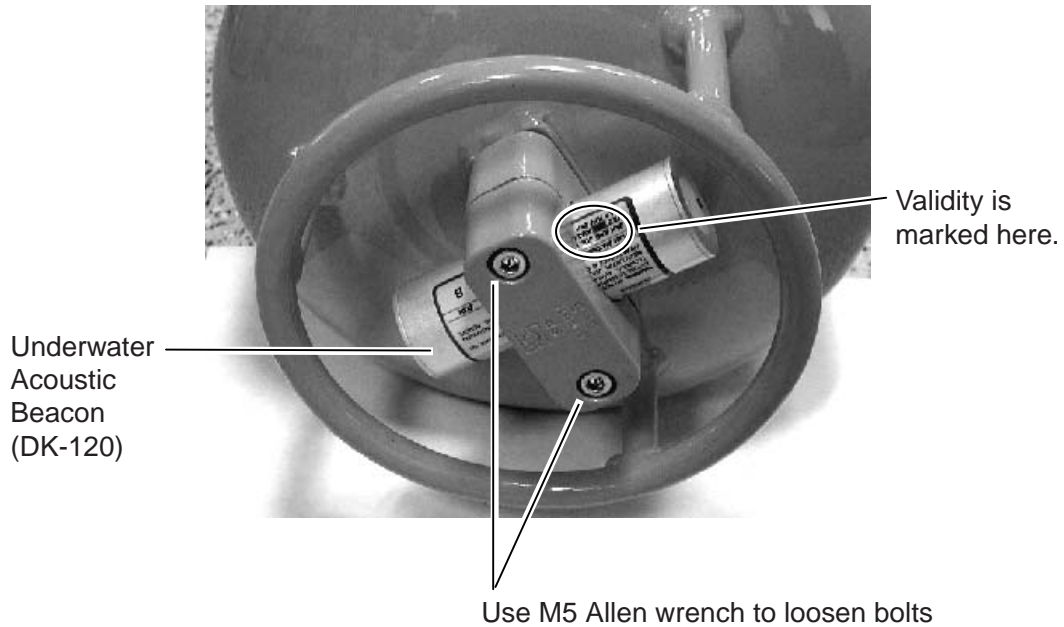

Underwater Acoustic Beacon on DRU

NOTICE

As the acoustic beacon contains a battery, it must be disposed of in accordance with appropriate regulations.

3. TROUBLESHOOTING

This chapter provides information on possible causes of problems you may experience with your VDR. If you still have a problem after referring to the table, contact your local dealer or national distributor for further advice. Always provide the product serial number.

3.1 General Trouble Finding

Use the table below to identify the trouble. The system provides the start-up self-test and the result is indicated by LEDs.

Troubleshooting table

Symptom	Possible causes	Possible solutions
AC and/or DC LED not lit	No power supply	Check the breaker switches.
BAT LED not lighting	No power from the battery	Call for service.
ERROR LED lighting in red	Malfunction of the system	Restart the system. If the problem still remains, call for service. Check integrity of DRU connection.

3.2 Error Codes

Error codes may appear on the status display on the Power Control Panel to alert to possible trouble. Below is a list of those codes

Error codes

Error Code No.	Name	Description	Action
---		Normal operation after two minutes	None
253	PRC_STATUS_OK_INDICATION	System is running normally with no errors pending	None
170	PRC_STATUS_FATAL_FAILURE_INDICATION	Fatal system error	Request service
010	PRC_STATUS_DRU_FAILURE_INDICATION	System is experiencing trouble communicating with DRU.	Trouble-shoot connection from VR-3000S to the DRU (cable, repeaters and possible IEEE1394 /FireWire – board in the DCU.)
014	PRC_STATUS_BACKUP_DEVICE_FAILURE	Backup device is either faulty or not set up correctly.	Replace or reconfigure backup device.
034	PRC_STATUS_STORAGE_FAILURE_INDICATION	Problem with storing data on storage devices.	Investigate LOG and repair or replace.
046	PRC_STATUS_DRU_INDEX_ERROR	Problem with INDEX in DRU	Investigate LOG and clear INDEX.
022	PRC_STATUS_STORAGE_DRU_CONNECTION_TIMEOUT	DRU has been discontinued more than 90 seconds.	Connect DRU again or investigate LOG and repair or replace.
062	PRC_STATUS_STORAGE_LAST_BUFFER_NOT_SAVED	Storage problem with DRU/BACKUP	Investigate LOG(if possible) or contact dealer for repair.
130	PRC_STATUS_DATAIO_FAILURE_INDICATION	Problem with ANALOG/DIGITAL interface board. Self-test program run during boot should indicate which board.	Replace faulty board.
042	PRC_STATUS_GRABBER_FAILURE_INDICATION	One of the active/enabled video channels can't grab from the channel. This can be either because radar is turned OFF or wrong configuration.	If radar is turned OFF, press ACK on the RAP to silence alarm. Error will clear when radar is turned ON again. If radar is ON, check installation(cabling) and configuration.

Error codes (con't from previous page)

Error Code No.	Name	Description	Action
186	PRC_STATUS_GRABBER_IMAGE_TOO_BIG	Video image captured from radar is larger than expected.	Check quality of captured image, colormask(video channels) and re-adjust framegrabber.
138	PRC_STATUS_CONFIG_FAILURE_INDICATION	Unexpected error when trying to read CONFIG.	Check that installed firmware version is correct for connected DRU. If this is a new DTU, CONFIG_area needs to be cleared.
154	PRC_STATUS_CONFIG_INVALID_START_TAG	CONFIG_area in the DRU is clean. This should only happen during installation/service. This will also be displayed after first boot after clearing CONFIG_area.	Restart VR-3000S.
150	PRC_STATUS_CONFIG_INVALID_SIZE	Size of CONFIG_area in the DRU is different from expected one. This should only happen during installation/service and upgrade of the system software.	Clear CONFIG_area and restart VR-3000S. This will install a "default" minimum configuration.
090	PRC_STATUS_CONFIG_INVALID_FLASH_HANDLE	CONFIG_area in the DRU is corrupt/wrong un-initialized. This should only happen during installation/service and if using a DRU not initialized by the VR-3000S it is connected to.	Clear CONFIG_area and restart VR-3000S. This will install a "default" minimum configuration.
162	PRC_STATUS_CONFIG_MISSING_IN_FLASH	CONFIG_area in the DRU is corrupt/wrong un-initialized. This should only happen during installation/service and if using a DRU not initialized by the VR-3000S it is connected to.	Clear CONFIG_area and restart VR-3000S. This will install a "default" minimum configuration.

Error codes (con't from previous page)

Error Code No.	Name	Description	Action
086	PRC_STATUS_CONFIG_VDRDEFAULT_ERROR	Built-in configuration in VR-3000S system software failed to load into the DRU. Reason can be firmware itself or a problem with the DRU.	Clear CONFIG_area and restart VR-3000S. This will install a “default” minimum configuration. If the error still occurs, try to see if the DRU is set up correctly (partitions, partition size).
102	PRC_STATUS_CONFIG_UNABLE_TO_SAVE	VR-3000S could not save configuration to the DRU/BACKUPDRIVE.	Check DRU connected; BACKUP DRIVE OK; For other call for service.
026	PRC_STATUS_TIMEDIFF_TOO_BIG	Communication port defined to deliver UTC time info delivered UTC time that is more than 1 hour different from VR-3000S system clock. This normally happens if GPS or time source sending the info is out of sync, or the system clock wasn't set to UTC time before starting.	Try to see if the CMOS clock is set correctly. If not, set it and restart VR-3000S. If yes, find out why the time source device defined in the WEB-configurator is delivering “out of bands” time info.
218	PRC_STATUS_MIC_TEST_FAILED	Microphone test failed to test the microphones defined in the WEB_configurator. This test can be run from MENU 13 in the WEB_configurator, and is run every 12 hours during normal operation (first time 12 hours after system start up).	Check if microphones mounted are disabled in the WEB_configurator. (AUDIO section>channels(3, 4, 5)). If this is OK, locate the faulty microphone and check/replace it.
301-316	PRC_SERIAL_MIC_TIMEOUT (250)	A serial channel has not delivered data within the specified timeout period.	Reconnect serial data. Check failed device.
214	PRC_STATUS_RUNNING_ON_BATTERY	Both AC and DC power are down. Audible alarms will only be generated for max. 2 min.	Reconnect AC or DC power.

Error codes (con't from previous page)

Error Code No.	Name	Description	Action
246	PRC_STATUS_PDU_NO_CONNECTION	The cable between the Power Control Panel and DPU is not connected.	Reconnect cable between the Power Control Panel and DPU.
082	PRC_STATUS_RAP_MISSING	RAP is missing. Connection to RAP is lost.	Check cable connected to RAP. Reconnect RAP.
206	PRC_RECORDING_STOPPED_INDICATION	VR-3000S has stopped recording. System has been running on BATTERY only for more than 2 hours, or index has been cleared and system has not been rebooted.	Reconnect AC or DC. The system will start recording after 30 sec.
106	PRC_STATUS_SYSTEM_STOPPED	SYSTEM_STOP request has been completed (system has stopped collecting data).	Turn OFF power to power down, or recycle POWER to restart.
238	PRC_SYSTEM_DRIVE_FAILURE	System did not find valid system drive(DRU).	Check that valid DRU is connected. (Validated flashdrives installed.)
234	PRC.UTC_TIMEOUT	System has not received UTC info within 2 minutes after system start up.	Check that a valid UTC source is connected to the serial port defined as UTC source.
254	PRC_SELFTEST_FAILED	System failed the SELFTEST.	Connect via web browser or VGA screen to see reason for failure.
226	PRC_NUM_FLASH_DRU_ERROR	System failed to find correct number of flash drives in DRU.	Check communication with DRU.
094	PRC_RECORDING_BACKUP_INACTIVE	Could not record data to backup HD.	Check backup HD.
098	PRC_RECORDING_DRU_INACTIVE	Could not record data to DRU.	Check DRU.
084	VDR_AP_MISSING	No alarm panel connection	Check connection to alarm panel.
089	VDR_RJB_MISSING	No remote junction box connection	Check connection to remote junction box.

4. LOCATION OF PARTS

4.1 Parts Location

4.1.1 Data Collecting Unit (VR-3010)

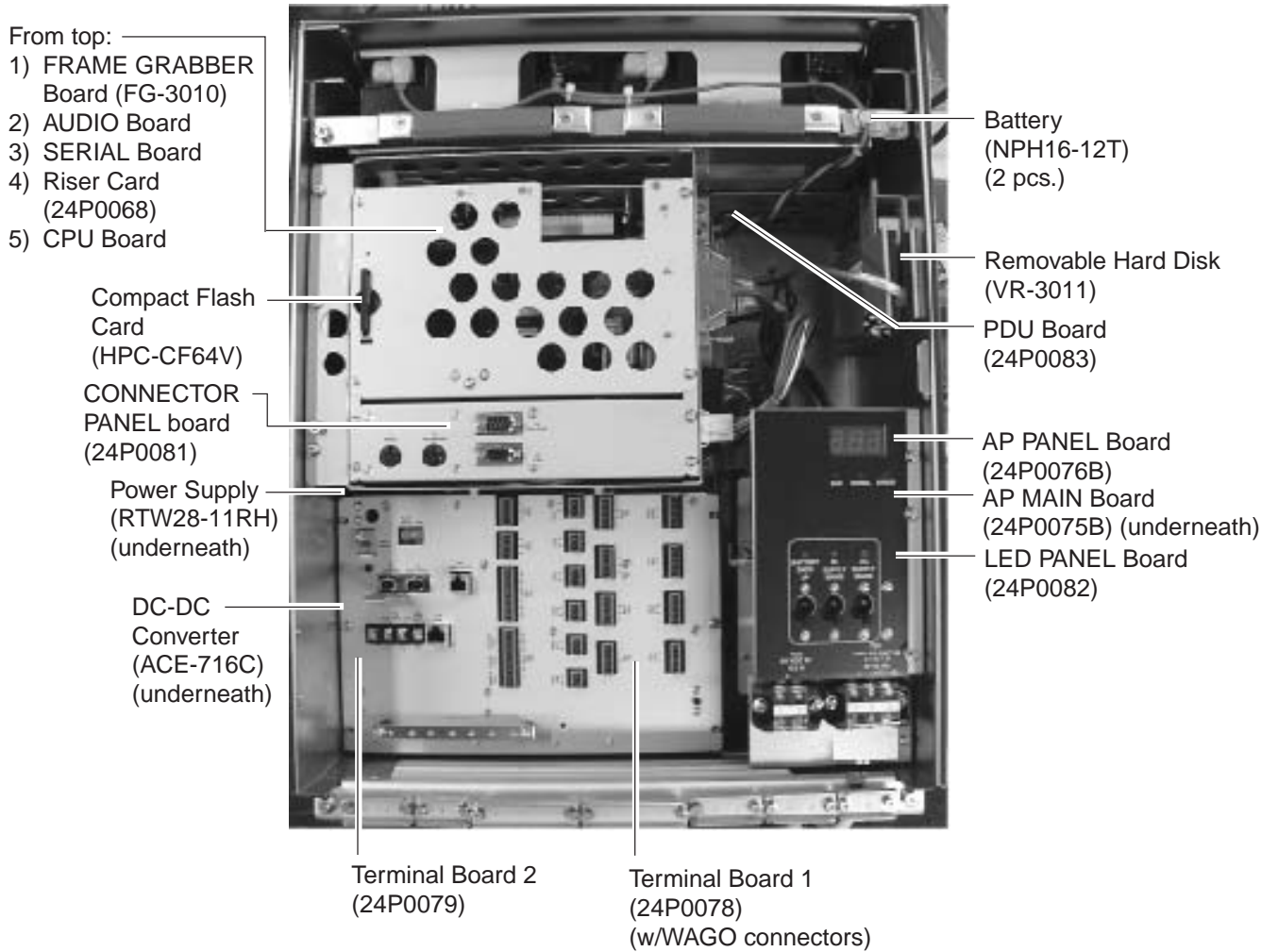

Data Collecting Unit (VR-3010)

4.1.2 Data Recording Unit (VR-5020-9G or VR-5020-6G)

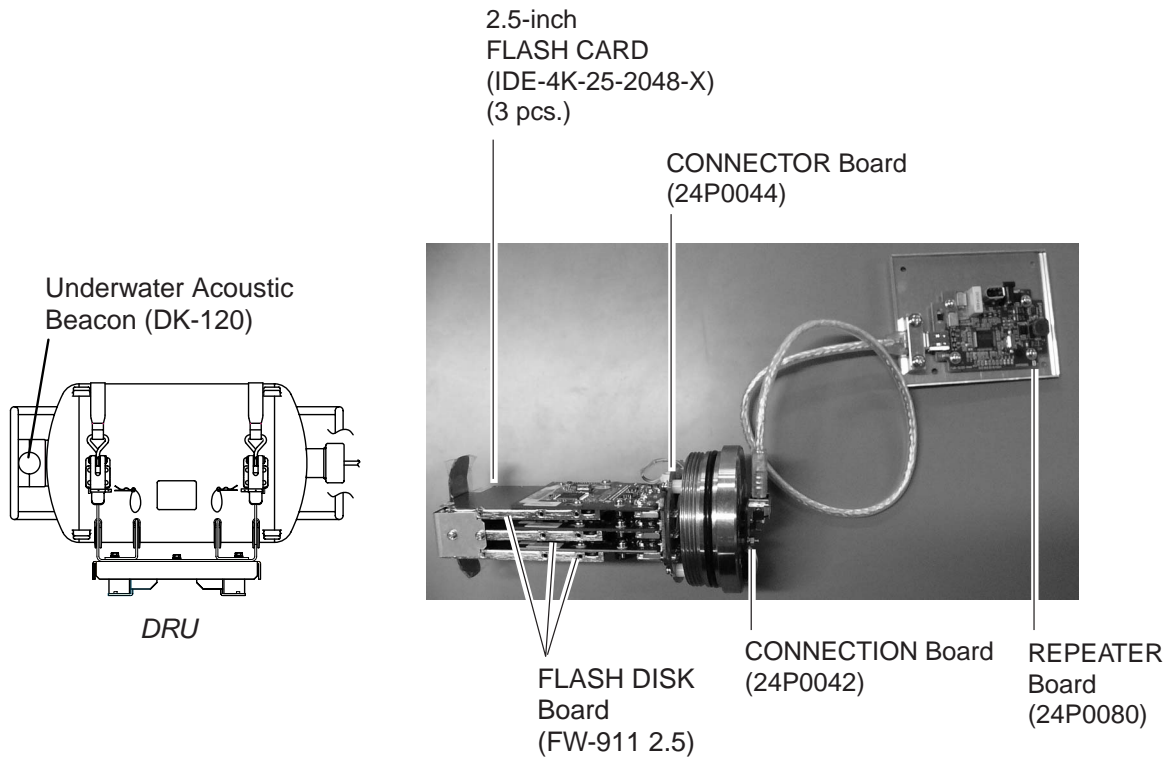

Components inside capsule

Data Recording Unit (VR-5020-9G or VR-5020-6G)

4.1.3 Remote Junction Box (IF-8530)

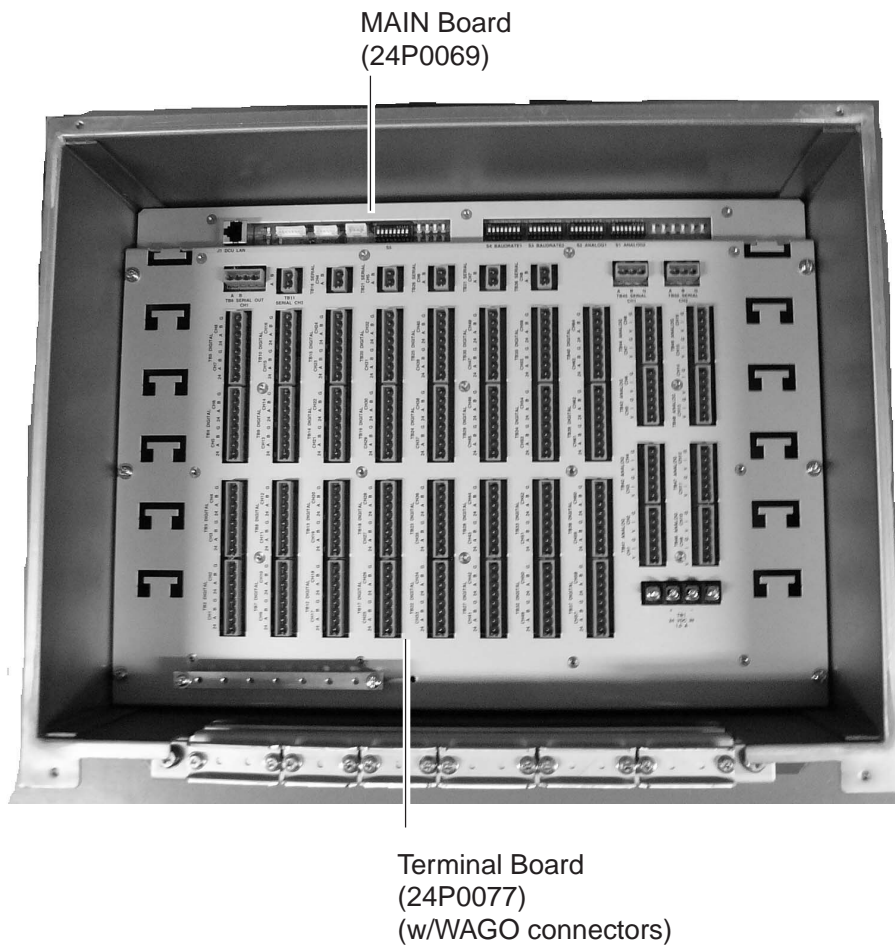

Remote Junction Box (IF-8530)

4.1.4 Remote Alarm Panel (VR-3016)

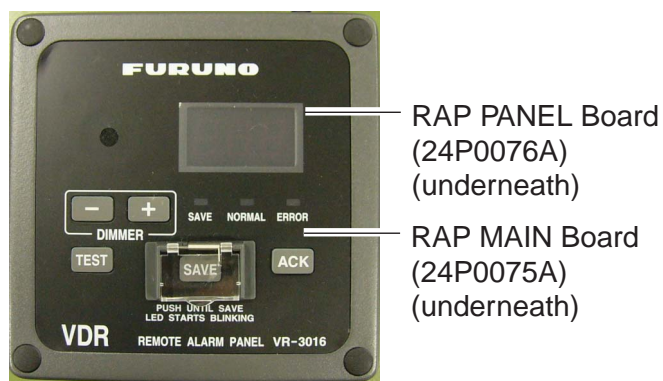

Remote Alarm Panel (VR-3016)

4.2 Parts List

This equipment contains complex modules in which fault diagnosis and repair down to component level are not practical (IMO A.694(17)/8.3.1. Only some discrete components are used. FURUNO Electric Co., Ltd. believes identifying these components is of no value for shipborne maintenance; therefore, they are not listed in this manual. Major modules can be located on the parts location on previous pages.

Name	Type	Remarks
Data Collecting Unit (VR-3010)		
AP MAIN Board	24P0075B	
AP PANEL Board	24P0076B	
AUDIO Board		
Battery	NPH16-12T	2 pcs.
Compact Flash Card	HPC-CF64V	
CONNECTOR PANEL Board	24P0081	
CPU Board		
DC-DC Converter	ACE-716C	
FRAME GRABBER Board	FG-3010	
LED PANEL Board	24P0082	
PDU Board	24P0083	
Power Supply	RTW28-11RH	
Riser Card	24P0068	
SERIAL Board		
Terminal Board 1	24P0078	
Terminal Board 2	24P0079	
Removable Hard Disk	VR-3011	
Data Recording Unit (VR-5020-9G or VR-5020-6G)		
CONNECTION Board	24P0044	
CONNECTOR Board	24P0042	
FLASH DISK Card	IDE-4K-25-2048-X	3 pcs.
FLASH DISK Board	FW-911 2.5	3 pcs.
REPEATER Board	24P0080	
Underwater Acoustic Beacon	DK-120	
Remote Junction Box (IF-8530)		
MAIN Board	24P0069	
Terminal Board	24P0077	
Remote Alarm Panel (VR-3010)		
RAP MAIN Board	24P0075A	
RAP PANEL Board	24P0076A	

5. INTERFACE

(IEC 61162-1, IEC-61162-2)

5.1 Data Sentences

Some sentences described here are proposed ones by the recent IEC TC80/WG6 (Digital Interface Working Group) at the time of this publication. They are marked with PAS 101, PAS 102, etc.

ALA - Set detail alarm condition

0 1 2 3 4 5 6 7 8 9
\$xxALA, hhhmss.ss, aa, aa, xx, xxx, A, A, c--c *hh<CR><LF>

0: Header 1: Event time (Optional) 2: System indicator of alarm source
3: Sub-system/equipment/item indicator of alarm source 4: Number of equipment / units / items
5: Number of alarm source 6: Alarm condition 7: Alarm's acknowledge state
8: Alarm's description text 9: Check-sum

ALR - Set alarm status (PAS 101)

Updated the text label of the alarm identification field to be the same as that field in the ACK sentence.

\$--ALR, hhhmss.ss, xxx, A, A, c--c *hh<CR><LF>

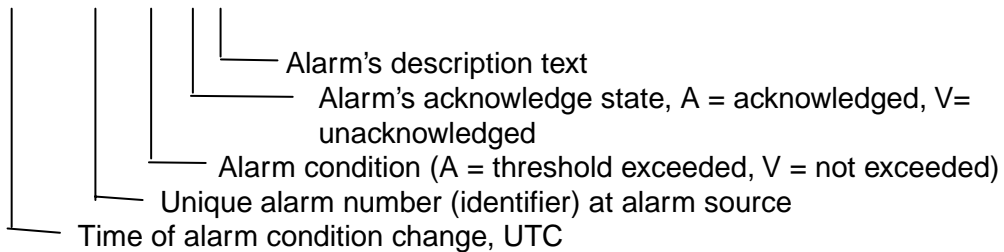

DOR - Door status indication

This sentence indicates the status of watertight doors, fire doors and other hull openings / doors. Malfunction alarms of the watertight door, fire door and hull opening/door controller should be included in the “ALA” sentence.

\$xxDOR, A, hhmmss.ss, aa, aa, xxx, xxx, A, c—c, *hh<cr><lf>

0 1 2 3 4 5 6 7 8 9

0) Header

1) Message type

S: Status for section: the number of faulty and/or open doors reported in the division specified in field 4. The section may be a whole section (one or both of the division indicators are empty) or a sub-section. (If S is used then it shall be transmitted at regular intervals.)

E: Status for single door. (E may be used to indicate an event).

F: Fault in system: If limited to one section, indicated by division indicator fields, if not, division indicators empty. (F may be used to indicate an event.)

2) Time stamp

Time when this status/message was valid.

3) System indicator of door status

Indicator characters as door system. The field is two fixed characters.

4) Division indicator of door allocation (1)

Indicator showing division where door is located. This field is two characters.

It may be physical fire zone or entity identifier for control and monitoring system, e.g., central number.

5) Division indicator of door allocation (2)

Indicator showing in which division the door is located. This field is three numeric characters.

It may be physical deck number or identifier for control and monitoring system sub-system, e.g., loop number.

6) Door number or door open count

Number showing door number or number of doors that are open/faulty.

This field is three fixed numeric characters.

7) Door status

This field includes a single character specified by the following: when S status indicated in 2nd field, this field is ignored

O = Open

C = Close

F = Free status (for watertight door)

X = Fault (impossible to know state)

8) Message's description text

Additional and optional descriptive text/door tag. Also if a door allocation identifier is string type, it is possible to use this field instead of above door allocation fields.

Maximum number of characters will be limited by maximum sentence length and length of other fields.

DPT - Depth

IMO Resolution A.224 (VII). Water depth relative to the transducer and offset of the measuring transducer. Positive offset numbers provide the distance from the transducer to the waterline. Negative offset numbers provide the distance from the transducer to the part of the keel of interest.

\$--DPT, x.x, x.x*hh<CR><LF>

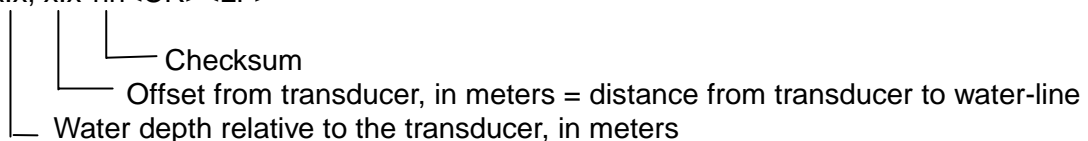

DTM - Datum reference (to be further developed)

Local geodetic datum to which a position location is referenced.

\$--DTM, ccc, a*hh<CR><LF>

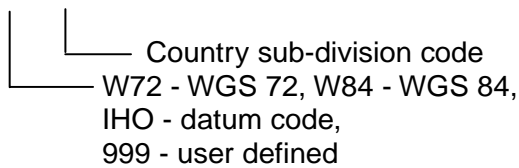

ETL - Engine telegraph operation status

The ETL sentence indicates engine telegraph position including operating location and sub-telegraph indicator

\$xxETL, hhmmss.ss, a, xx, xx, a, x, *hh<cr><lf>

0 1 2 3 4 5 6 7

- 0) Header
- 1) Event Time
- 2) Indicator of command
O = Order
A = Answerback
- 3) Position indication of engine telegraph
00 = Stop engine
01 = [AH] Dead Slow
02 = [AH] Slow
03 = [AH] Half
04 = Full
05 = [AH] Nav. Full
11 = [AS] Dead Slow
12 = [AS] Slow
13 = [AS] Half
14 = [AS] Full
15 = [AS] Crash Astern
- 4) Position indication of sub telegraph
20 = S/B (Stand-by engine)
30 = F/A (Full away – Navigation full)
40 = F/E (Finish with engine)
- 5) Operating location indicator
B = Bridge
P = Port wing 1
S = Starboard wing 1
C = Engine control room
E = Engine side
- 6) Number of engine or propeller shaft
0 = single or on centre-line
Odd = starboard
Even = port
- 7) Checksum

FIR - Fire detection (PAS 102)

0 1 2 3 4 5 6 7 8 9 10
\$xxFIR, A, hhmss.ss, aa, xx, xxx, xxx, A, A, c--c, *hh<CR><LF>

0: Header 1: message type 3: System indicator of fire detection 4: Division indicator of door allocation (1) 5: Division indicator of door allocation (2) 6: Fire detector number or activation detection number count 7. Condition 8: Alarm's acknowledge state 9: Alarm's description text 10: Check-sum

GEN - Generic status information

This sentence provides a means of transmitting multi-sensor generic status information from any source, in a format that can be registered by the VDR. The sentence is designed for efficient use of the bandwidth and must be accompanied with a description of how to interpret the information. Each sentence holds a base address for all status groups. Each group is assigned a 16-bit address. Up to eight contiguous groups with increasing address may be transmitted in a single sentence. Data is blocked in 16-bit groups. Unused bits shall be assigned a fixed value to simplify data compression.

A separate configuration with interpretation of bit equal to "1" and "0" for all sentence groups and bit positions that are used, must be provided as this information is not included in the sentence. It is the responsibility of the talker to provide this information.

\$xxGEN, hhhh, hhmss.ss, hhhh[,hhhh], *hh<cr><lf>

0 1 2 3 4

0) Header

1) Address of first group in sentence

Address of first group in GEN sentence. Address is represented in hexadecimal format in range 0x0000 through 0xFFFF.

The 16-bit address is formatted as fixed 4-character HEX field.

2) Time stamp

Time when status was valid.

3) Packed generic status group

The packed generic status group is represented as a 6-bit value.

The 16-bit value is formatted as fixed 4-character HEX field.

4) Optional repeat of field 3

Optional repeated packed generic status field. Each repeat increases the status address by one.

Up to seven repetitions yielding a total of 128 status bits per sentence is possible.

hh = Check sum

GNS - GNSS fix data

Fix data for single or combined satellite navigation systems (GNSS).

\$--GNS,hhmmss.ss,llll.lll,a,yyyyy.yyy,a,c--c,xx,x.x,x.x,x.x,x.x,x.x*x*hh<CR><LF>

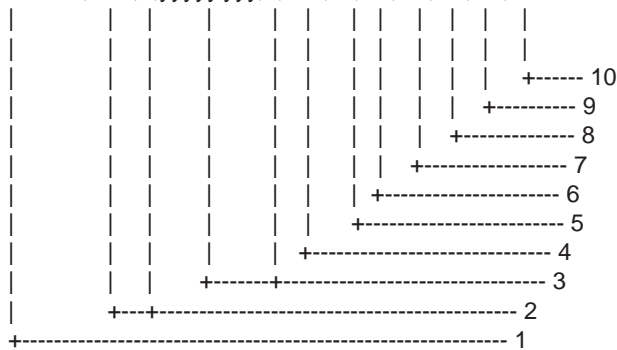

1. UTC of position
2. Latitude, N/S
3. Longitude, E/W
4. Mode indicator
5. Total number of satellite in use,00-99
6. HDOP
7. Antenna altitude, metres, re:mean-sea-level(geoid)
8. Geoidal separation
9. Age of differential data
10. Differential reference station ID
11. Checksum

HDG - Heading Magnetic

\$--HDG,x.x,x.x,a,x.x,a*hh<CR><LF>

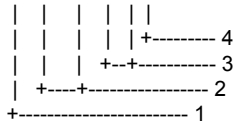

1. Magnetic sensor heading, degrees
2. Magnetic deviation, degrees E/W
3. Magnetic variation, degrees E/W
4. Checksum

HDT - Heading True

\$--HDT, x.x, T*hh<CR><LF>

\$--HDT,x.x,T*hh<CR><LF>

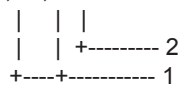

1. Heading, degrees true
2. Checksum

MWV - Wind speed and angle (PAS 102)

When the reference field is set to relative, data is provided giving the wind angle in relation to the vessel's heading and wind speed, both relative to the moving vessel.

When the reference field is set to true, data is provided giving the wind angle relative to the vessel's heading and wind speed, both with reference to the moving water. True wind is the vector sum of the relative apparent wind vector and the vessel's velocity vector along the heading line of the vessel. It represents the wind at the vessel if it were stationary relative to the water and heading in the same direction.

\$--MWV,x.x,a,x.x,a,A*hh<CR><LF>

```
| | | | | |
| | | | | +----- 6
| | | | | +----- 5
| | | | | +----- 4
| | | | | +----- 3
| | | | | +----- 2
+----- 1
```

1. Wind angle, 0 to 359 (degrees)
2. Reference, R=relative, T=true
3. Wind speed
4. Wind speed units, K/M/N
5. Status, A=data valid, V=data invalid
6. Checksum

PRC - Propulsion remote control status

This sentence indicates the engine control status (engine order) on a M/E remote control system. This provides the detail data not available from the engine telegraph.

\$xxPRC, x.x, A, x.x, A, x.x, A, x, *hh<cr><lf>

0 1 2 3 4 5 6 7 8

- 0) Header
- 1) Lever demand position
-100 - 0 - 100% from "full astern" (crash astern) to "full ahead" (navigation full) "stop engine"
- 2) Data status
A = data valid
V = data invalid
- 3) RPM demand
- 4) Data status
R = relative (%): 0-100% from zero to maximum rpm
T = true (rpm): "-"Astern
V = data invalid
- 5) Pitch demand
- 6) Data status
R = relative (%): -100 - 0 - 100% from "full astern" (crash astern) to "full ahead" (navigation full) "stop engine"
T = true (degree): "-"Astern
V = data invalid
- 7) Number engine or propeller shaft
0 = single or on centre-line
Odd = starboard
Even = port
- 8) Checksum

RPM - Revolutions (PAS 102)

Shaft or engine revolution rate and propeller pitch.

\$--RPM, a, x, x.x, x.x, A*hh<CR><LF>

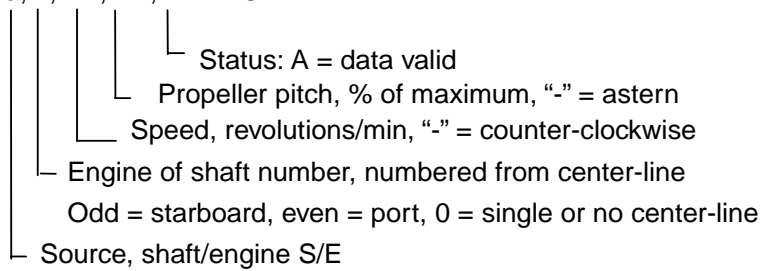

RSA - Rudder sensor angle

\$--RSA, x.x, A, x.x, A*hh<CR><LF>

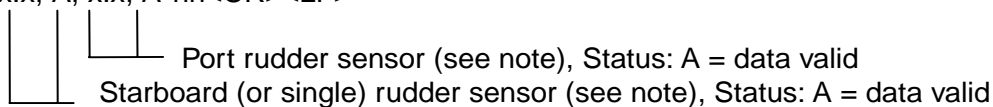

NOTE - Relative measurement of rudder angle without units, "-" = turn to port. Sensor output is proportional to rudder angle but not necessarily 1 : 1.

TRC - Thruster control data

This sentence provides the control data for thruster devices

\$xxTRC, x, x.x, A, x.x, A, x.x, *hh<cr><lf>

0 1 2 3 4 5 6 7

- 0) Header
- 1) Number of thrusters
Odd = Bow thruster
Even = Stern thruster
- 2) RPM demand
- 3) Data status
R = relative (%): 0-100% from zero to maximum rpm
T = true (deg) V = data invalid
- 4) Pitch demand value
"- " port
- 5) Data status
R = relative (%)
T = True (deg)
V = Data invalid
- 6) Azimuth demand
Direction of thrust in degrees (0 deg - 360 deg)
for thrusters capable of rotating direction of thrust
- 7) Checksum

TRD - Thruster response data

This sentence provides the response data for thruster devices.

\$xxTRD, x, x.x, A, x.x, A, x.x, *hh<cr><lf>

0 1 2 3 4 5 6 7

- 0) Header
- 1) Number of thrusters
Odd = Bow thruster
Even = Stern thruster
- 2) RPM demand
- 3) Data status
R = relative (%): 0-100% from zero to maximum rpm
T = true (deg) V = data invalid
- 4) Pitch response value
"- " port
- 5) Data status
R = relative (%)
T = True (deg)
V = Data invalid
- 6) Azimuth demand
Direction of thrust in degrees (0 deg - 360 deg)
for thrusters capable of rotating direction of thrust
- 7) Checksum

VBW - Dual ground/water speed: This sentence to be expanded as shown below:

\$--VBW,x.x,x.x,A,x.x,x.x,A,x.x,A,x.x,A*hh<CR><LF>

```

| | | | | | | | | | | |
| | | | | | | | | | | +--- 11
| | | | | | | | | | | +----- 10
| | | | | | | | | | | +----- 9
| | | | | | | | | | | +----- 8
| | | | | | | | | | | +----- 7
| | | | | | | | | | | +----- 6
| | | | | | | | | | | +----- 5
| | | | | | | | | | | +----- 4
| | | | | | | | | | | +----- 3
| | | | | | | | | | | +----- 2
| | | | | | | | | | | +----- 1

```

- 1. Longitudinal water speed, knots
- 2. Transverse water speed, knots
- 3. Status: water speed, A=data valid V=data invalid
- 4. Longitudinal ground speed, knots
- 5. Transverse ground speed, knots
- 6. Status: ground speed, A=data valid V=data invalid
- 7. Stern transverse water speed, knots
- 8. Status: stern water speed, A=data valid V=data invalid
- 9. Stern transverse ground speed, knots
- 10. Status: stern ground speed, A=data valid V=data invalid
- 11. Checksum

VDM - UAIS VHF Data-link Message (IEC 61162-2, for AIS)

!--VDM,x,x,x,x,s--s,x*hh<CR><LF>

```
| | | | | | |
| | | | | | +--- 7
| | | | | +---- 6
| | | | +----- 5
| | | +----- 4
| | +----- 3
| +----- 2
+----- 1
```

1. Total number of sentences needed to transfer the message, 1 to 9
2. Message sentence number, 1 to 9
3. Sequential message identifier, 0 to 9
4. AIS channel Number
5. Encapsulated ITU-R M.1371 radio message
6. Number of fill-bits, 0 to 5
7. Checksum

VDO - UAIS VHF Data-link Own-vessel report (IEC 61162-2, for AIS)

!--VDO,x,x,x,x,s--s,x*hh<CR><LF>

```
| | | | | | |
| | | | | | +--- 7
| | | | | +---- 6
| | | | +----- 5
| | | +----- 4
| | +----- 3
| +----- 2
+----- 1
```

1. Total number of sentences needed to transfer the message, 1 to 9
2. Message sentence number, 1 to 9
3. Sequential message identifier, 0 to 9
4. AIS channel Number
5. Encapsulated ITU-R M.1371 radio message
6. Number of fill-bits, 0 to 5
7. Checksum

WAT - Water level detection (PAS 102)

This sentence provides detection status of water leakage and bilge water level, with monitoring location data. Malfunction alarm of the water level detector should be included in the "ALA" sentence.

\$xxWAT, A, hhmmss.ss, aa, aa, xx, xxx, A, c—c, *hh<cr><lf>

0 1 2 3 4 5 6 7 8 9

0) Header

1) Message type

S: Status for section: Number of faulty and activated condition reported as number in field 4.

The section may be a whole section (one or both of the division indicators are empty) or a sub-section. (If S is used then it shall be transmitted at regular intervals)

E: Status for each water level detector. (E may be used to indicate an event.)

F: Fault in system: If limited to one section, indicated by division indicator fields, if not, division indicators [empty]. (F may be used to indicate an event).

2) Time stamp

Time when this status/message was valid.

3) System indicator of alarm source

Indicator characters showing system detecting water level. The field is two characters.

4) Location (1)

Indicator characters showing detection location. The field is two characters.

5) Location (2)

Indicator characters showing detection location. The field is two characters.

6) Number of detection point or detection point number

Number showing high-water-level detecting point or the number of the water leakage detection point. This field is three fixed numeric characters.

7) Alarm condition

This field is a single character specified by the following:

N = normal state

H = alarm state (threshold exceeded)

J = alarm state (extreme threshold exceeded)

L = alarm state (Low threshold exceeded i.e. not reached)

K = alarm state(extreme low threshold exceeded i.e. not reached)

X = Fault (state unknown)

When S status indicated in 2nd field, this field is ignored

8) Descriptive text

Additional and optional descriptive text/level detector tag.

9) Checksum

XDR - Transducer measurements

Measurement data from transducers that measure physical quantities such as temperature, force, pressure, frequency, angular or linear displacement, etc. Data from a variable number of transducers measuring the same or different quantities can be mixed in the same sentence. This sentence is designed for use by integrated systems as well as transducers that may be connected in a "chain" where each transducer receives the sentence as an input and adds its own data fields on before retransmitting the sentence.

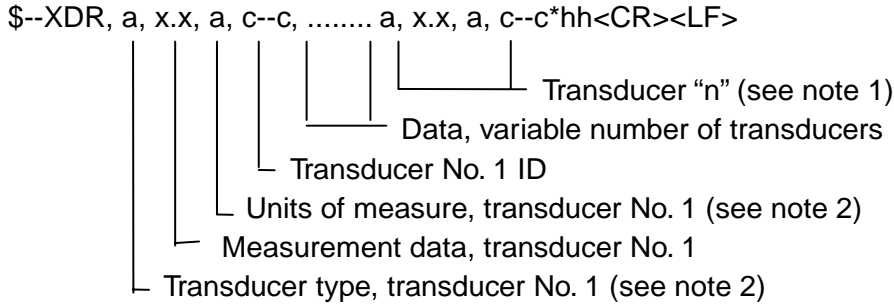

NOTES

1 Sets of the four fields "type-data-units-ID" are allowed for an undefined number of transducers. Up to "n" transducers may be included within the limits of allowed sentence length, null fields are not required except where portions of the "type-data-units-ID" combination are not available.

ZDA - Time and date

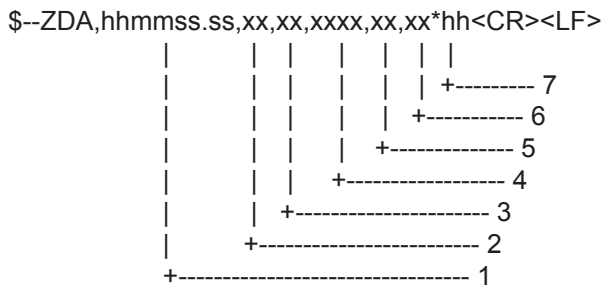

1. UTC
2. Day, 01 to 31(UTC)
3. Month, 01 to 12(UTC)
4. Year(UTC)
5. Local zone hours, 00h to +-13h
6. Local zone minutes, 00 to +59 as local hours
7. Checksum

NOTE - Zone description if the number of whole hours added to local time to obtain GMT. Zone description is negative for east longitudes.

5.2 Interface Circuits

5.2.1 IEC 61162-1

DCU

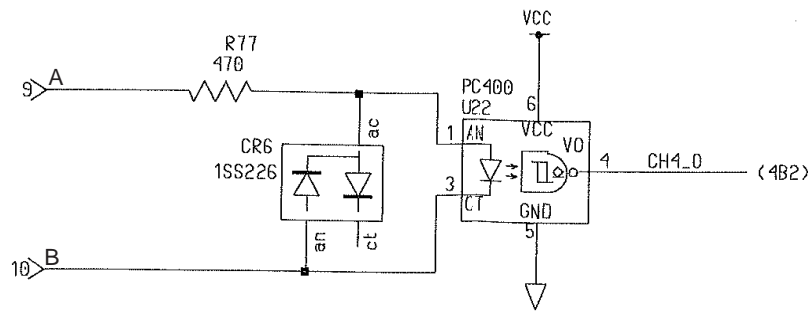

RJB

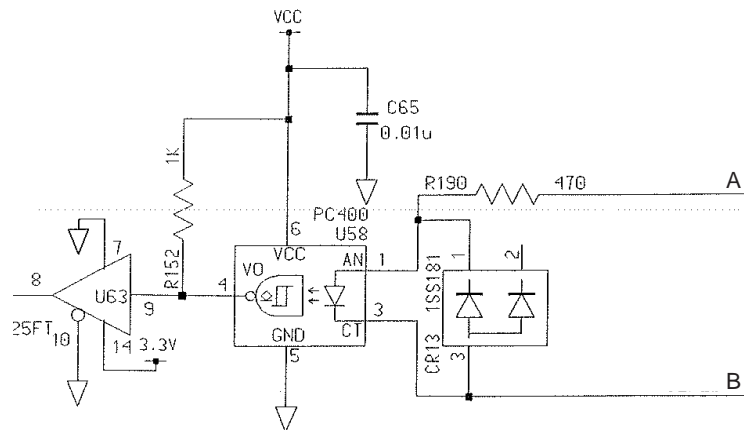

**SPECIFICATIONS OF THE VOYAGE DATA RECORDER
VR-3000**

The Voyager Data Recorder (VDR) is a new system required on certain categories of ships from 1st July 2002 by the revised SOLAS Chapter V. VR-3000 fully complies with the IMO Resolution A. 861 (20) and IEC 61996 testing standard. The standard VDR consists of a Data Collecting Unit, a Data Recording Unit in the robust protective capsule, Interface modules, an Uninterruptible Power Supply, a Junction box and ancillary units.

1 GENERAL

- 1.1 Recording Period 12 hours, IEC61996.4.5.4 - A. 861.5.3.3
- 1.2 Recording Medium Solid state component in a protected capsule
- 1.3 Reserve Power Source Lead acid battery (12VDC, 16 AH x 2pcs.)
IEC61996.4.5.3 - A. 861.5.3.2

2 DATA COLLECTING UNIT (DCU) : VR-3010

- 2.1 CPU Intel Pentium M 1.6Ghz
- 2.2 Memory 512 M byte of PC-333 SDRAM
- 2.3 Interface IEC 61162-1/2 : 2ch
IEC 61162-1/NMEA0183 : 6ch
VIDEO : 1ch / 2ch / 4ch
AUDIO(MICROPHONE) : 6ch (775mV AC/600 ohm)
AUDIO(VHF) : 2ch (775mV AC/600 ohm)
Remote Ack Input : 1ch (Dry Contact a/b)
System Fail Output : 1ch (Dry Contact a/b)
Local Ack Output : 1ch (Dry Contact a/b)
Ethernet 100Base-T : 1ch (For Live Player)

3 DATA RECORDING UNIT (DRU) : VR-5020

- 3.1 Chassis Protective capsule
- 3.2 Shock Resistant 50G x 11 ms
- 3.3 Penetration Resistance 250 kg weight, dropped from 3 m height
- 3.4 Fire Resistant 1100°C for 1 hour, 260°C for 10 hour
- 3.5 Submersible 6000 m
- 3.6 Acoustic Beacon DK120 / Replaced every 6 years

4 REMOTE JUNCTION BOX (RJB) : IF-8530

4.1	Power Supply	24VDC from DCU	
4.2	Interface	IEC 61162-1/2	: 2ch
		IEC 61162-1/NMEA0183	: 6ch
		CONTACT (a/b)	: 64ch
		ANALOG ($\pm 10V, 0-20mA$)	: 16ch

5 MICROPHONE : VR-5011

5.1	AGC Amplifier Output	775mV AC/600 ohm
5.2	Frequency Response	0 dB (150Hz to 6 kHz)
5.3	Power Supply	24VDC from DCU
5.4	Audio Coverage	Cylindrical area of approx. 5 m in diameter Distance: approx. 2 m
5.5	On-board Beeper	1s in 12 hours period (built in)

6 POWER SUPPLY

100-230 VAC, 1 phase, 50/60 Hz, 200VA
(With Emergency Power Supply)
24VDC, 7.5A Max

7 ENVIRONMENTAL CONDITION

7.1	Ambient temperature	IEC 60945
	Data collecting unit (VR-3010)	-15°C to +55°C
	Data recording unit (VR-5020)	-25°C to +55°C (IEC61996)
	Others	-15°C to +55°C
7.2	Relative humidity	95% at 40°C
7.3	Waterproofing	IEC 60952
	Data collecting unit (VR-3010)	IP20
	Data recording unit (VR-5020)	IPX7 (IEC61996)
	Remote junction box (IF-8530)	IP20
	Remote alarm panel (VR-3016)	IP20
	Microphone (VR-5011)	IP20
7.4	Vibration	IEC 60945

8 COATING COLOR

8.1	Data collecting unit (VR-3010)	2.5GY5/1.5
8.2	Data recording unit (VR-5020)	Fluorescent orange
8.3	Remote junction box (IF-8530)	2.5GY5/1.5
8.4	Remote alarm panel (VR-3016)	N3.0
8.5	Microphone (VR-5011)	2.5GY5/1.5

**SPECIFICATIONS OF THE SIMPLIFIED VOYAGE DATA RECORDER
VR-3000S**

The Simplified Voyager Data Recorder (S-VDR) is the system required by IMO MSC.163(78). VR-3000S fully complies with the IMO MSC.163(78) and IEC/PAS 61996 testing standard. The standard VDR consists of a Data Collecting Unit, a Data Recording Unit in the robust protective capsule, Interface modules, an Uninterruptible Power Supply, a Junction box and ancillary units.

1 GENERAL

- 1.1 Recording Period 12 hours, IEC61996.4.5.4 - A. 861.5.3.3
- 1.2 Recording Medium Solid state component in a capsule
- 1.3 Reserve Power Source Lead acid battery (12VDC, 16 AH x 2pcs.)
IEC61996.4.5.3 - A. 861.5.3.2

2 DATA COLLECTING UNIT (DCU) : VR-3010

- 2.1 CPU Intel Pentium M 1.6Ghz
- 2.2 Memory 512 M byte of PC-333 SDRAM
- 2.3 Interface IEC 61162-1/2 : 2ch
IEC 61162-1/NMEA0183 : 6ch
VIDEO : 1ch / 2ch / 4ch (Option:FG-3010)
AUDIO(MICROPHONE) : 6ch (775mV AC/600 ohm)
AUDIO(VHF) : 2ch (775mV AC/600 ohm)
Remote Ack Input : 1ch (Dry Contact a/b)
System Fail Output : 1ch (Dry Contact a/b)
Local Ack Output : 1ch (Dry Contact a/b)
Ethernet 100Base-T : 1ch (For Live Player)

3A DATA RECORDING UNIT (DRU) : VR-5020

- 3.1 Chassis Protective capsule
- 3.2 Shock Resistant 50G x 11 ms
- 3.3 Penetration Resistance 250 kg weight, dropped from 3 m height
- 3.4 Fire Resistant 1100°C for 1 hour, 260°C for 10 hour
- 3.5 Submersible 6000 m
- 3.6 Acoustic Beacon DK120 / Replaced every 6 years

3B DATA RECORDING UNIT (DRU) : VR-3030

- | | | |
|-----|--------------------|--|
| 3.7 | Chassis | Float Free capsule (A.810(19)) |
| 3.8 | 406 EPIRB Approved | COSPAS-SARSAT T.001 class2
RTCM SC110-STD Version2 class2
ETS 300 066
IEC 61097-2 |
| 3.9 | Battery | LO26SX sulphur-dioxide D-cell / Replaced every 6 years |

4 REMOTE JUNCTION BOX (RJB) : IF-8530 (OPTION)

- | | | |
|-----|--------------|--|
| 4.1 | Power Supply | 24VDC from DCU |
| 4.2 | Interface | IEC 61162-1/2 : 2ch
IEC 61162-1/NMEA0183 : 6ch
CONTACT (a/b) : 64ch
ANALOG ($\pm 10V, 0-20mA$) : 16ch |

5 MICROPHONE : VR-5011

- | | | |
|-----|----------------------|--|
| 5.1 | AGC Amplifier Output | 775mV AC/600 ohm |
| 5.2 | Frequency Response | 0 dB (150Hz to 6 kHz) |
| 5.3 | Power Supply | 24VDC from DCU |
| 5.4 | Audio Coverage | Cylindrical area of approx. 5 m in diameter
Distance: approx. 2 m |
| 5.5 | On-board Beeper | 1s in 12 hours period (built in) |

6 POWER SUPPLY

100-230 VAC, 1 phase, 50/60 Hz, 200VA Max.
(With Emergency Power Supply)
24VDC, 7.5A Max.

7 ENVIRONMENTAL CONDITION

- | | | |
|-----|--------------------------------|----------------------------|
| 7.1 | Ambient temperature | IEC 60945 |
| | Data collecting unit (VR-3010) | -15°C to +55°C |
| | Data recording unit (VR-5020) | -25°C to +55°C (IEC61996) |
| | Data recording unit (VR-3030) | -20°C to +55°C (IEC 61097) |
| | Others | -15°C to +55°C |
| 7.2 | Relative humidity (All Unit) | 95% at 40°C |
| 7.3 | Waterproofing | IEC 60952 |

Data collecting unit (VR-3010)	IP20
Data recording unit (VR-5020)	IPX7 (IEC61996)
Data recording unit (VR-3030)	IPX7 (IEC 61097)
Remote junction box (IF-8530)	IP20 (Option)
Remote alarm panel (VR-3016)	IP20
Microphone (VR-5011)	IP20
7.4 Vibration	IEC 60945

8 COATING COLOR

8.1 Data collecting unit (VR-3010)	2.5GY5/1.5
8.2 Data recording unit (VR-5020)	Fluorescent Orange
8.3 Data recording unit (VR-3030)	Orange
8.4 Remote junction box (IF-8530)	2.5GY5/1.5 (Option)
8.5 Remote alarm panel (VR-3016)	N3.0
8.6 Microphone (VR-5011)	2.5GY5/1.5



(Elemental Chlorine Free)

The paper used in this manual
is elemental chlorine free.

© **FURUNO ELECTRIC CO., LTD.**

9-52 Ashihara-cho,
Nishinomiya 662-8580, JAPAN

Telephone : 0798-65-2111

Fax : 0798-65-4200

FURUNO Authorized Distributor/Dealer

All rights reserved.

Printed in Japan

Pub. No. OME-44370

(DAMI) VR-3000

FIRST EDITION : NOV. 2005

A1 : NOV. 29, 2005



* 0 0 0 1 5 7 0 7 8 0 0 *



* O M E 4 4 3 7 0 A 1 0 *