

FURUNO

OPERATOR'S MANUAL

NAVTEX RECEIVER

MODEL NX-300



FURUNO ELECTRIC CO., LTD.
NISHINOMIYA, JAPAN



(Elemental Chlorine Free)

The paper used in this manual
is elemental chlorine free.

© **FURUNO ELECTRIC CO., LTD.**

9-52 Ashihara-cho,
Nishinomiya 662-8580, JAPAN

Telephone : 0798-65-2111

Fax : 0798-65-4200

FURUNO Authorized Distributor/Dealer

All rights reserved.

Printed in Japan

Pub. No. OME-56290

(YOSH) NX-300

FIRST EDITION :MAR. 2000

J2 :NOV. 01, 2005



* 0 0 0 8 0 9 0 0 0 2 *



* O M E 5 6 2 9 0 J 2 0 *



SAFETY INSTRUCTIONS

Safety Instructions for the Operator



WARNING



Do not open the cover of the equipment.

Only qualified personnel should work inside the equipment.

Immediately turn off the power at the ship's mains switchboard if water or foreign object falls into the equipment or the equipment is emitting smoke or fire.

Continued use of the equipment can cause fire, electrical shock and serious injury.

Do not disassemble or modify the equipment.

Fire, electrical shock or serious injury can result.



CAUTION

Keep heater away from equipment.

A heater can melt the equipment's power cord, which can cause fire or electrical shock.



Use the proper fuse.



Use of the wrong fuse can cause fire or equipment damage.

Do not operate the equipment with wet hands.

Electrical shock can result.

Safety Instructions for the Installer

 WARNING	
	<p>Do not open the cover unless totally familiar with electrical circuits and service manual.</p> <p>Improper handling can result in electrical shock.</p>
<p>Turn off the power at the ship's mains switchboard before beginning the installation. Post a warning sign near the switchboard to ensure that the power will not be applied while the equipment is being installed.</p> <p>Serious injury or death can result if the power is not turned off, or is applied while the equipment is being installed.</p>	

 CAUTION							
	<p>Ground the equipment to prevent mutual interference.</p>						
<p>Confirm that power supply voltage is compatible with the voltage rating of the equipment.</p> <p>Connection to the wrong power supply can cause fire or equipment damage. The voltage rating appears on the label at the rear of the equipment.</p>							
<p>Observe the following compass safe distances to prevent interference to a magnetic compass:</p> <table border="1"><thead><tr><th></th><th>Standard compass</th><th>Steering compass</th></tr></thead><tbody><tr><td>NX-300</td><td>0.5 m</td><td>0.3 m</td></tr></tbody></table>			Standard compass	Steering compass	NX-300	0.5 m	0.3 m
	Standard compass	Steering compass					
NX-300	0.5 m	0.3 m					

CONTENTS

FOREWORD	v
A Word to NX-300 Owners.....	v
Features.....	vi
SYSTEM CONFIGURATION.....	vii
EQUIPMENT LISTS	viii
1. PRINCIPLE OF NAVTEX SYSTEM.....	1-1
1.1 How NAVTEX Works	1-1
1.2 NAVTEX System Operation.....	1-1
1.3 Message Format.....	1-2
1.4 Display Indications.....	1-3
1.5 NAVTEX Station Map.....	1-4
1.6 NAVTEX Station List	1-5
2. OPERATION.....	2-1
2.1 Control Description	2-1
2.2 Turning the Power On/Off.....	2-1
2.3 Adjusting Dimmer and Contrast.....	2-2
2.4 Menu Operation Overview	2-2
2.5 Selecting Stations	2-3
2.6 Selecting Messages.....	2-4
2.7 Setting Functions (FUNCTIONS menu)	2-5
2.8 Selecting Language.....	2-9
2.9 Displaying Messages.....	2-9
2.10 Sample Messages	2-10
2.11 Displaying Navigation Data.....	2-11
2.12 Selecting Receive Frequency.....	2-12
3. SYSTEM MENU	3-1
3.1 Units of Measurement.....	3-1
3.2 Time Difference (using local time)	3-2
3.3 Time Display	3-3
3.4 Default Setting	3-3

3.5 Delete All Messages	3-4
3.6 User Display of Navigation Data	3-4
4. OTHER FUNCTIONS	4-1
4.1 DEMO Mode.....	4-1
4.2 VIEW Mode	4-1
4.3 All Clear.....	4-1
4.4 Changing Received Message Log Window	4-2
5. MAINTENANCE & TROUBLESHOOTING	5-1
5.1 Maintenance.....	5-1
5.2 Diagnostic Test	5-1
5.3 When the Battery Icon Appears.....	5-2
5.4 Replacement of Fuse.....	5-3
6. INSTALLATION.....	6-1
6.1 Installation of Display Unit.....	6-1
6.2 Installation of Antenna Unit	6-2
6.3 Wiring.....	6-3
6.4 Interfacing	6-4
MENU TREE.....	AP-1
SPECIFICATIONS	SP-1
PACKING LIST.....	A-1
OUTLINE DRAWINGS	D-1
INTERCONNECTION DIAGRAM.....	S-1
INDEX.....	index-1
Declaration of Conformity	

FOREWORD

A Word to NX-300 Owners

Congratulations on your choice of the FURUNO NX-300 NAVTEX Receiver. We are confident that you will enjoy many years of operation with this fine piece of equipment.

For over 50 years FURUNO Electric Company has enjoyed an enviable reputation for quality and reliability throughout the world. Our extensive global network of agents and dealers furthers this dedication to excellence.

The NX-300 is just one of the many FURUNO developments in the field of marine radio communication. The NX-300 provides cost-effective price, high sensitivity and simple operation in one compact and light-weight unit. In addition to its fundamental function of receiving NAVTEX broadcasts, this unit can also function as nav data display when connected to navigation equipment.

This unit is designed and constructed to ensure the user many years of trouble-free operation. To obtain full performance from the equipment, however, you should carefully read and follow the recommended procedures for installation, operation and maintenance. No machine can perform its intended functions unless it is installed and maintained properly.

Thank you for considering and purchasing FURUNO equipment.

Features

NAVTEX (Navigational Telex) is a worldwide coastal telex broadcasting system. Coastal NAVTEX broadcasting stations with specific ID's transmit Navigational warnings, Meteorological warnings, Search and Rescue (SAR) information and other navigational information for NAVTEX receiver-equipped vessels sailing in coastal waters.

The FURUNO NX-300 NAVTEX receiver receives NAVTEX messages and automatically displays them together with station ID and message category information.

The service range of a NAVTEX station is typically 200-400 nautical miles. A NAVTEX station normally broadcasts every 4 hours.

The NAVTEX message is relevant for all types and sizes of vessels. The NX-300 is shipped from the factory equipped to receive 7 specific types of NAVTEX messages from all NAVTEX stations. However unnecessary stations can be rejected or necessary stations can be added by the "manual station selection" facility.

If ship's position data is fed from navigation equipment, the NX-300 automatically decides in which NAVAREA the vessel is navigating, and selects stations. (NAVAREAs are geographical zones defined by the International Maritime Organization.)

- Unattended operation once required data is entered.
- Received data is not saved nor displayed when the error rate exceeds the percentage you set (max 39%).
- No paper required
- Designed for small boats and fishing vessels
- Compact, stylish display and antenna units
- Memory of up to 28,000 characters for last 72 hours
- Navigation data can be fed through external input (connection with navigation aid required).
- Bright 95 x 60 mm LCD with adjustable contrast and brilliance
- Memory backup with a long-life lithium battery
- Low power consumption

SYSTEM CONFIGURATION

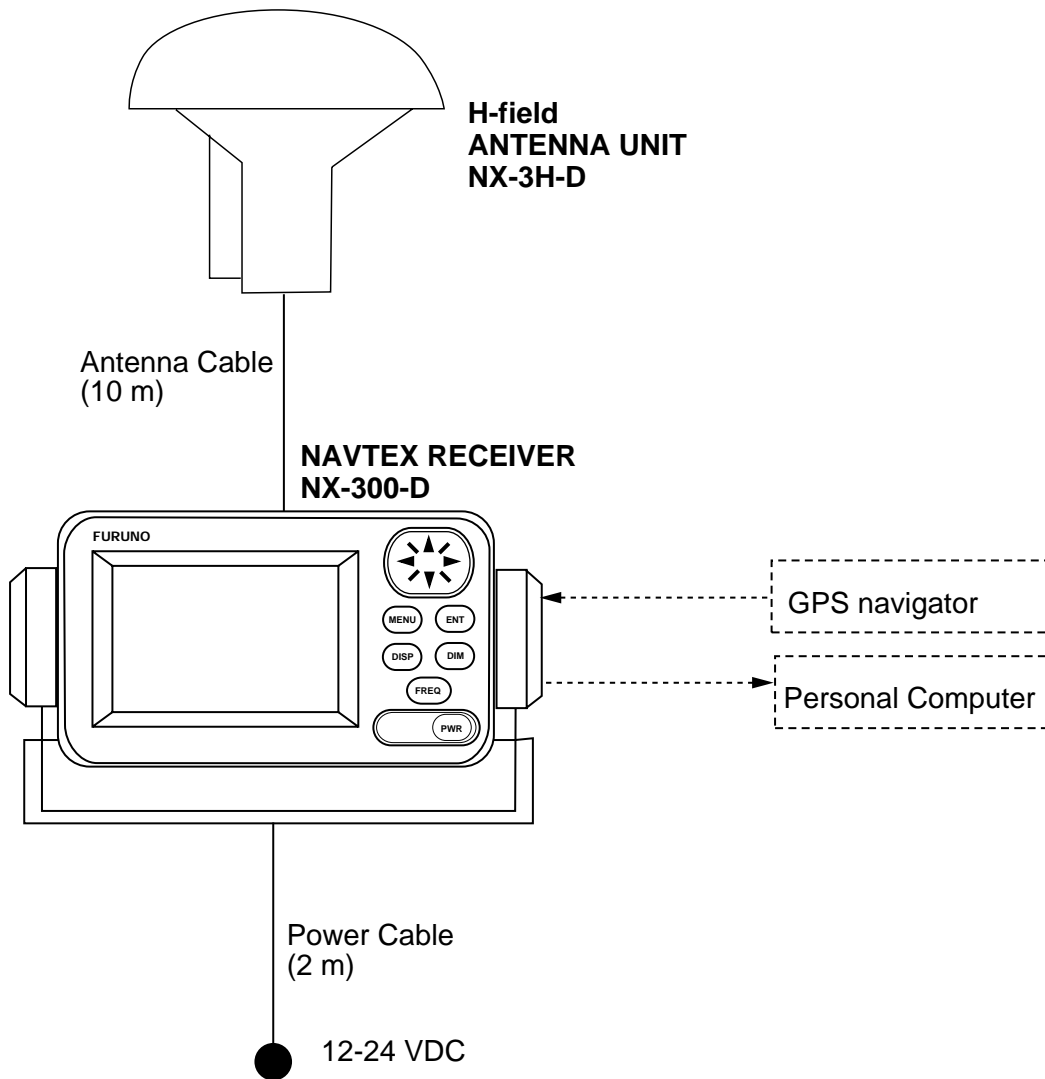

NX-300 System configuration

EQUIPMENT LISTS

Standard supply

Name	Type	Qty	Remarks
NAVTEX Receiver	NX-300-D	1	Including hanger and knob bolts
Antenna Unit	NX-3H-D		H-field type with 10 m cable
Installation Materials		1 set	Power/Data cable (Type: MJ-A7SPF0005-020, Code No.: 000-139-384) Tapping screw (4 pcs., for fixing NAVTEX receiver, Type: 5x20, Code No.: 000-802-081)
Spare Parts		1 set	Fuse (2 pcs., Type: FGMB 1A, Code No.: 000-114-805)
Accessories		1 set	Hard cover (Type: 20-016-1091, Code No.: 100-297-032)

Optional equipment

Name	Type	Code No.	Remarks
Right Angle Antenna Base	No. 13-QA330	000-803-239	For antenna unit
L-type Antenna Base	No. 13-QA310	000-803-240	
Handrail Antenna Base	No. 13-RC5160	000-806-114	
Mast Mount Kit	CP20-01111	004-365-780	
Flush Mount Kit S	OP-20-17	000-040-720	For flush mounting the NAVTEX receiver
Flush Mount Kit F	OP-20-29	000-041-405	

1. PRINCIPLE OF NAVTEX SYSTEM

1.1 How NAVTEX Works

There are many types of navigational and meteorological information available on radio, such as NAVAREA, HYDROPAC, etc. However, these systems rely heavily upon the operator's experience and skill in tuning the radio and interpreting messages. In addition, constant monitoring to pick up wanted information among a vast volume of messages is not practical with a limited radio staff.

To provide all mariners with up-to-the-minute information automatically, the NAVTEX system was developed.

NAVTEX is an acronym meaning Navigational Telex, and as its name shows, it is a kind of narrow band radio teletype system for sending (by frequency shift keying) text messages expressed in a 7-unit code. The difference is that a NAVTEX transmitter transmits nine control characters (header code) ahead of the main message, so that the receiver can identify the station, message type and serial number automatically.

1.2 NAVTEX System Operation

For navigation purposes, the world is divided into 16 areas (called Navareas) as shown in the figure below. Each Navarea has multiple NAVTEX stations and each NAVTEX station has an identification code, from "A" to "Z." The frequency assigned to NAVTEX is only one (518 kHz), and many stations exist in the same Navarea. (Some stations use 490 kHz also.)

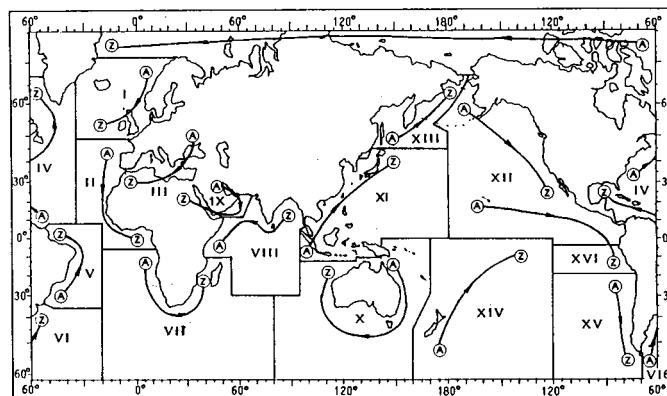

Figure 1-1 NAVTEX area

If the stations were to transmit without any rule, the system would collapse due to mutual interference. To avoid this problem, the following rules apply.

- The transmission schedule is determined so that two or more stations having a common service area may not overlap in time.
- Each station transmits with minimum required power to cover its service area (200 nautical miles nominal).

1.3 Message Format

For automatic identification of messages, each message starts with eight control characters, called "Header codes".

The first four characters are always "ZCZC" and common to all messages. This part is used for message synchronization. The latter four characters are designated as b1, b2, b3 and b4 to indicate origin, category and serial number of the message.

Character b1 is the identification letter of the NAVTEX station; "A" to "Z". Character b2 indicates the type of message, "A" to "Z", as listed below. Character b3 and b4 indicate the serial number of the message. The serial numbers are counted up from "01" to "99", and start from "01" again. Number "00" is specially reserved for important emergency messages, such as a search and rescue (SAR) message.

The end of each message is indicated by "NNNN" (four successive N's).

General message format is summarized below.

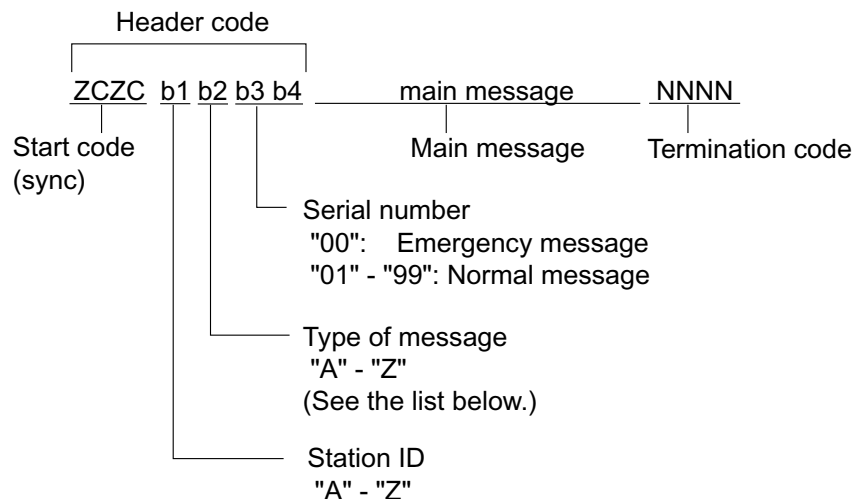

[Type of message (category)]

A:	Navigational warning	I:	OMEGA message
B:	Meteorological warning	J:	Differential OMEGA message
C:	Ice report	K:	Other electronic navigational aid system message
D:	Search and rescue information/ piracy and armed robbery	L:	Navigational warning (additional)
E:	Meteorological forecast	M to U:	Reserve-presently not used
F:	Pilot message	V:	Notice to Fishermen (U. S. only)
G:	DECCA message	W to Y	Reserve-presently not used
H:	LORAN-C message	Z:	QRU (no message on hand)

1.4 Display Indications

SAR: Displayed when message type D is displayed.

NEW: Displayed when message is displayed for the first time.

AUTO: Displayed when you select AUTO mode in STATION SELECTION.



Rx: Lights when message is being received.

SAR receiving: Lights (and the alarm sounds) when message type D is being received. Hitting any key silences the alarm.

WARNING: Appears when message type A, B or L is displayed.

WARNING receiving: Lights (and the alarm sounds) when message type A, B or L is received. Hitting any key silences the alarm.



BATTERY icon: Displayed when the battery voltage is low.

Scroll bar: Shows location in message displayed.

Figure 1-2 Display indications

1.5 NAVTEX Station Map

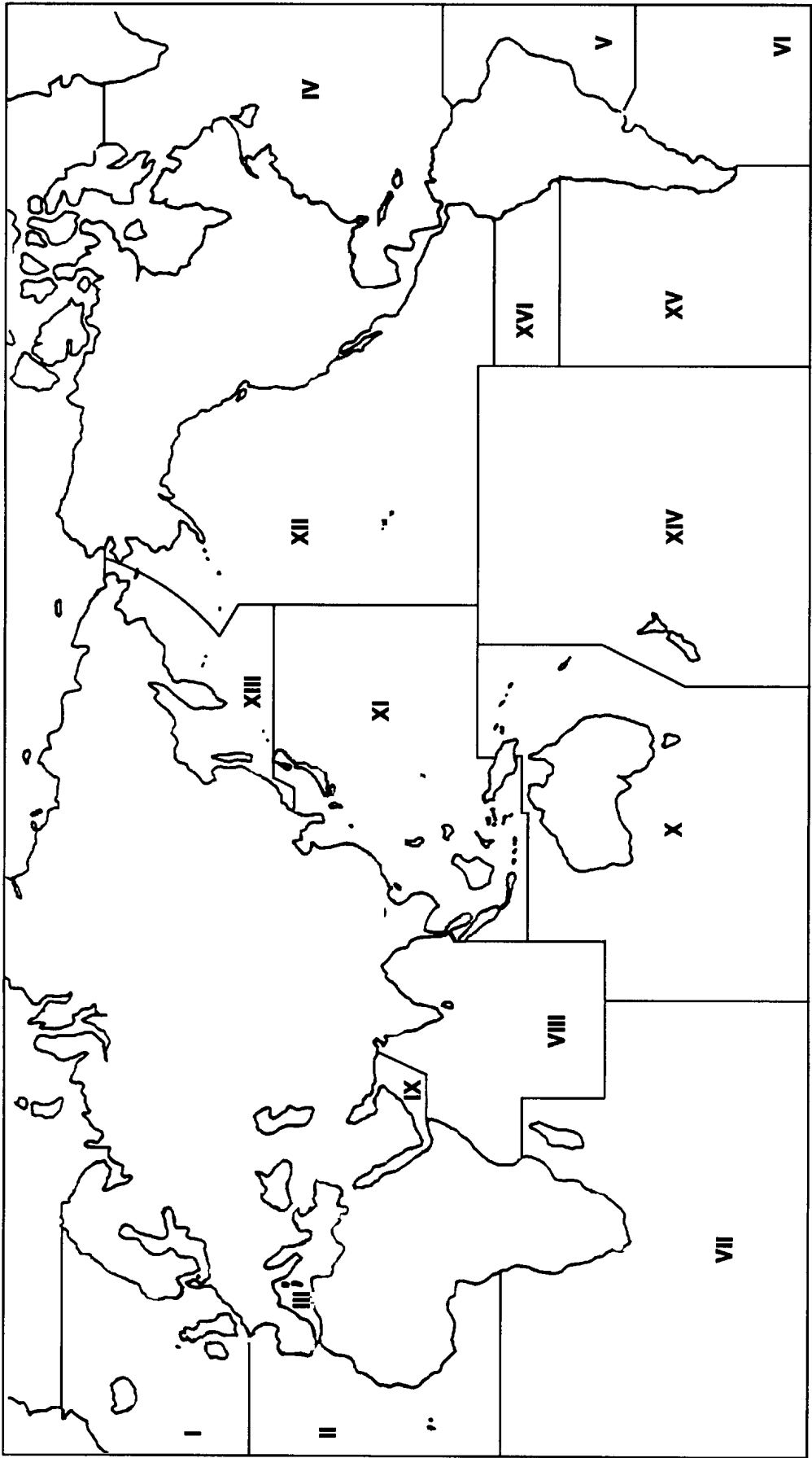

1.6 NAVTEX Station List

NAV area	Country	Station	Station Name (Less than 18 characters)	Station Name Characters	Latitude	Longitude	518kHz B1	490kHz B1	
I	Belgium	Oostende		8	51 11 N	02 48 E	M,T		
	Estonia	Tallinn		7	59 30 N	24 30 E	E,U		
	Iceland	Reykjavik Radio		15	64 05 N	21 51 W	R,X	R	
	Ireland	Valencia	Valentia		8	51 27 N	09 49 W	W	
		Malin Head			10	55 22 N	07 21 W	Q	
	France	Niton		5	50 35 N	01 18 W	K		
	Netherlands	Netherlands Coast Guard	Den Helder		10	52 06 N	04 15 E	P	
	Norway	Bodo Radio			10	67 16 N	14 23 E	B	
		Rogaland Radio			14	58 48 N	05 34 E	L	
		Vardoe Radio			12	70 22 N	31 06 E	V	
		Svalbard			8	78 04 N	13 38 E	A	
		Ørlandet	Orlandet		8	63 40 N	09 33 E	N	
	Sweden	Harnosand	Bjuroklubb		10	64 28 N	21 36 E	H	
		Karlskrona	Gislovshammar		13	55 29 N	14 19 E	J	
		Stockholm Radio			15	59 16 N	18 43 E	U,D	
		Gothenburg (Grimeton)	Grimeton		8	57 06 N	12 23 E	D	
	United Kingdom	Cullercoats			11	55 02 N	01 26 W	G	I,U
		Portpatrick			11	54 51 N	05 07 W	O	C
		Niton			5	50 35 N	01 18 W	K,S,E	A,I
		Oostende			8	51 11 N	02 48 E	M	
	Russian Federation	Murmansk			8	68 58 N	33 05 E	C	
Archangel				9	64 33 N	40 32 E	F		
II	Cameroon	Douala		6	N.I.	N.I.	N.I.		
	Cape Verde	Sao Vicente Radio		17	N.I.	N.I.	N.I.		
	France	Cross Corsen			12	48 28 N	05 03 W	A	E
		Niton			5	50 35 N	01 18 W		T
	Mauritania	Nouadhibou Radio		16	N.I.	N.I.	N.I.		
	Morocco	Casablanca Radio		16	33 36 N	07 38 W	M		
	Portugal	Horta Radio	Horta		5	38 32 N	28 38 W	F	J
		Monsanto Radio	Monsanto		8	38 44 N	09 11 W	R	G
Spain	Corunna	Coruna		6	43 21 N	08 27 W	D		

(Con't on next page)

NAV area	Country	Station	Station Name (Less than 18 characters)	Station Name Characters	Latitude	Longitude	518kHz B1	490kHz B1
II	Spain	Tarifa		6	36 01 N	05 34 W	G	
		Las Palmas		10	28 10 N	15 25 W	I	
III	Bulgaria	Varna		5	43 04 N	27 46 E	J	
	Croatia	Split	Split radio	11	43 30 N	16 29 E	Q	
	Cyprus	Cyprus	Cypradio	8	35 03 N	33 17 E	M	
	Egypt	Alexandria		10	31 12 N	29 52 E	N	
		Serapeum		8	30 28 N	32 22 E	X	
	France	Cross La Garde	Toulon	6	43 06 N	05 59 E	W	S
	Greece	Heraklion	Iraklion	8	35 20 N	25 07 E	H	
		Corfu	Kerkyra	7	39 37 N	19 55 E	K	
		Lemnos	Limnos	6	39 52 N	25 04 E	L	
	Israel	Haifa		5	32 49 N	35 00 E	P	
	Italy	Roma		4	41 48 N	12 31 E	R	
		Augusta		7	37 14 N	15 14 E	S,V	
		Cagliari		8	39 14 N	09 14 E	T	
		Trieste		7	45 41 N	13 46 E	U	
	Malta	Malta		5	35 49 N	14 32 E	O	
	Russian Federation	Novorossiysk		12	44 42 N	37 44 E	A	
		Astrakhan		9	46 18 N	47 58 E	W	
	Spain	Cabo de la Nao		14	38 43 N	00 09 E	X	
	Turkey	Istanbul		8	41 04 N	28 57 E	D	
		Samsun		6	41 17 N	36 20 E	E	
Antalya			7	36 53 N	30 42 E	F		
Izmir			5	38 22 N	26 36 E	I		
Ukraine	Mariupol		8	47 06 N	37 33 E	B		
	Odessa		6	46 29 N	30 44 E	C		
IV	Bermuda (UK)	Bermuda		7	32 23 N	64 41 W	B	
	Canada	Sept Iles	Riviere-au-Renard	17	50 11 N	66 07 W	C,D	
		Prescott	Wiaraton	7	44 20 N	81 10 W	H	
		St. Johns		9	47 30 N	52 40 W	O	
		Thunder Bay		11	48 25 N	89 20 W	P	
		Sydney, Nova Scotia	Sydney, NS	10	46 10 N	60 00 W	Q,J	
Yarmouth		8	43 45 N	66 10 W	U,V			

(Con't on next page)

NAV area	Country	Station	Station Name (Less than 18 characters)	Station Name Characters	Latitude	Longitude	518kHz B1	490kHz B1
IV	Canada	Montreal		8	45 41 N	73 16 W	W,T	
		Labrador		8	53 42 N	57 01 W	X	
		Iqaluit, NU		11	63 43 N	68 33 W	T	S
	Denmark (Greenland-West Coast)	Godthaab(Nuuk)		14	64 04 N	52 01 W	W	
	United States	Miami		5	25 37 N	80 23 W	A	
		Boston		6	41 43 N	70 30 W	F	
		New Orleans		11	29 53 N	89 57 W	G	
		Chesapeake	Portsmouth	10	36 43 N	76 00 W	N	
		San Juan	Isabella	8	18 28 N	67 04 W	R	
		Savannah, GA		12	32 08 N	81 42 W	E	
Netherlands Antilles	Curacao		7	12 10 N	68 52 W	H		
V	Uruguay	Colonia		7	N.I.	N.I.	N.I.	
		Laguna del Sauce		16	N.I.	N.I.	N.I.	
		La Paloma		9	34 40 S	54 09 W	F	A
		Montevideo		10	34 52 S	56 19 W	N.I.	
		Punta del Este		14	34 58 S	54 57 W	N.I.	
		Salto		5	N.I.	N.I.	N.I.	
VI	Argentina	Ushaia		6	54 48 S	68 18 W	A,M	
		Rio Gallegos		12	51 37 S	65 03 W	B,N	
		Comodoro Rivadavia		18	45 51 S	67 25 W	C,O	
		Bahia Blanca		12	38 43 S	62 06 W	D,P	
		Mar del Plata		14	38 03 S	57 32 W	E,Q	
		Buenos Aires		12	34 36 S	58 22 W	F,R	
	Uruguay	La Paloma		9	34 40 S	54 09 W	F	A
VII	Namibia	Walvis Bay		10	23 03 S	14 37 E	B	
	South Africa	Cape Town		9	33 40 S	18 43 E	C	
		Port Elizabeth		14	34 02 S	25 33 E	I	
		Durban		6	30 00 S	31 30 E	O	
VIII	India	Bombay	Mumbai	6	19 05 N	72 50 E	G	
		Madras		6	13 08 N	80 10 E	P	
	Mauritius	Mauritius Radio		15	20 10 S	57 28 E	C	

(Con't on next page)

NAV area	Country	Station	Station Name (Less than 18 characters)	Station Name Characters	Latitude	Longitude	518kHz B1	490kHz B1
IX	Bahrain	Hamala		6	26 09 N	50 28 E	B	
	Egypt	Serapeum (Ismailia)	Serapeum	8	30 28 N	32 22 E	X	
		Quseir	Kosseir	7	26 06 N	34 17 E	V	
	Iran	Bushehr		7	28 59 N	50 50 E	A	
		Bandar Abbas		12	27 07 N	56 04 E	F	
	Saudi Arabia	Jeddah		6	21 23 N	39 10 E	H	
	Oman	Muscat		6	23 36 N	58 30 E	M	
Pakistan	Karachi		7	24 51 N	67 03 E	P		
X				0			NONE	
XI	China	Sanya		5	18 14 N	109 30 E	M	
		Guangzhou		9	23 08 N	113 32 E	N	
		Fuzhou		6	26 01 N	119 18 E	O	
		Shanghai		8	31 08 N	121 33 E	Q	
		Dalian		6	38 52 N	121 31 E	R	
	Indonesia	Jayapura		8	02 31 S	140 43 E	A	
		Ambon		5	03 42 S	128 12 E	B	
		Makassar		8	05 06 S	119 26 E	D	
		Jakarta		7	06 06 S	106 54 E	E	
	Japan	Otaru		5	43 19 N	140 27 E	J	
		Kushiro		7	42 57 N	144 36 E	K	
		Yokohama		8	35 14 N	139 55 E	I	
		Moji		4	34 01 N	130 56 E	H	
		Naha		4	26 05 N	127 40 E	G	
	Korea, Republic of	Chukpyun	Chukpyong	9	37 03 N	129 26 E	V	J
		Pyonsan	Pyongsan	8	35 36 N	126 29 E	W	K
	Malaysia	Penang		6	05 26 N	100 24 E	U	
		Miri		4	04 28 N	114 01 E	T	
		Sandakan		8	05 54 N	118 00 E	S	
	Philippines	Manila		6	14 35 N	121 03 E	J	
		Puerto Princesa		15	09 44 N	118 43 E	I	
		Davao		5	07 04 N	125 36 E	K	
	Singapore	Singapore		9	01 25 N	103 52 E	C	
Thailand	Bangkok Radio		13	13 43 N	100 34 E	F		
United States	Guam		4	13 29 N	144 50 E	V		

(Con't on next page)

NAV area	Country	Station	Station Name (Less than 18 characters)	Station Name Characters	Latitude	Longitude	518kHz B1	490kHz B1
XI	Vietnam	Ho Chi Minh City		16	10 47 N	106 40 E	X	
		Haiphong		8	20 44 N	106 44 E	P,W	W
		Danang		6	16 05 N	108 13 E	W,P,K	
	Taiwan	Chilung		7	25 09 N	121 44 E	P	
		Kaohsiung (Linyüan)	Kaohsiung	9	22 29 N	120 25 E		P
Associate Member of IMO	Hong Kong		9	22 13 N	114 15 E	L		
XII	Canada	Prince Rupert		13	54 20 N	130 20 W	D	
		Tofino		6	48 55 N	125 35 W	H	
	United States	San Francisco		13	37 55 N	122 44 W	C	
		Kodiak		6	57 46 N	152 34 W	J,X	
		Honolulu		8	21 22 N	158 09 W	O	
		Cambria		7	35 31 N	121 03 W	Q	
		Astoria		7	46 10 N	123 49 W	W	
		Adak		4	51 54 N	176 38 W	X	
XIII	Russian Federation	Kholmsk		7	47 02 N	142 03 E	B	
		Murmansk		8	68 46 N	32 58 E	C	
		Arkhangelsk		11	64 51 N	40 17 E	F	
		Astrakhan		9	45 47 N	47 33 E	W	
XIV				0		NONE		
XV	Chile	Antofagasta		11	23 40 S	70 25 W	A,H	
		Valparaiso		10	32 48 S	71 29 W	B,I	
		Talcahuano		10	36 42 S	73 06 W	C,J	
		Puerto Montt		12	41 30 S	72 58 W	D,K	
		Punta Arenas		12	53 09 S	70 58 W	E,L	
		Isla de Pascua		14	27 09 S	109 25 W	F,G	
XVI	Peru	Paíta		5	05 05 S	81 07 W	S	
		Callao		6	12 03 S	77 09 W	U	
		Mollendo		8	17 01 S	72 01 W	W	
	Ecuador	Guayaquil		9	02 17 S	79 52 W	M	

Note: The list shows the stations listed at Longwave Navtex Broadcasts (2004).

This page is intentionally left blank.

2. OPERATION

2.1 Control Description

All operation of the NX-300 is carried out with the controls on the front panel of the display unit.

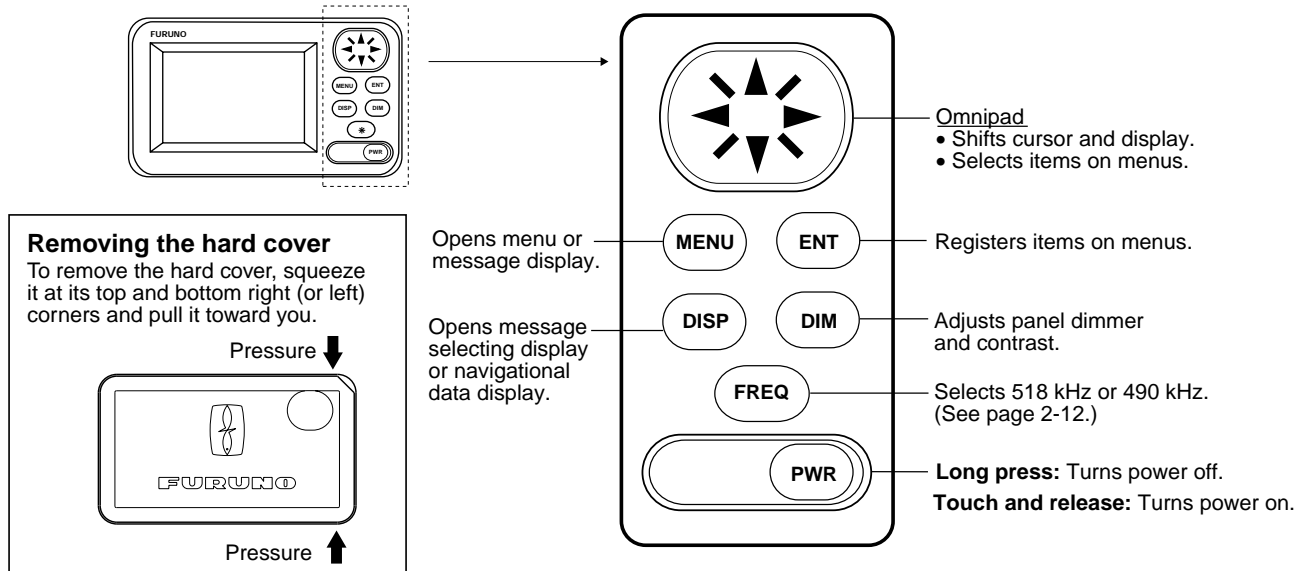

Figure 2-1 Control panel

2.2 Turning the Power On/Off

Turning on: Press the [PWR] key. "NO MESSAGE" (message waiting screen) appears. When a message is received, it appears on the screen and in case of a long message, it scrolls continuously.

To confirm version number of the equipment, press the [PWR] key a little longer. Release the key when the following window appears.



Figure 2-2 TURNING ON window

Turning off: Press the [PWR] key for 3 seconds.



Figure 2-3 TURNING OFF window

Note: The NX-300 should be turned on for the duration of a voyage so that important warning messages will not be missed.

2.3 Adjusting Dimmer and Contrast

1. Press the [DIM] key to show the dimmer and contrast setting window.



Figure 2-4 DIMMER and CONTRAST setting window

2. Press ▲ or ▼ for best illumination of the control panel and LCD.
3. Press ◀ or ▶ for best contrast of the LCD.
4. Press the [ENT] key to close the dimmer and contrast setting window.

Note: If you turn off the power with contrast less than 36, contrast is automatically set to 36 when you turn on the power again.

2.4 Menu Operation Overview

The menu allows you to custom tailor the NX-300 according to your needs. You can select which categories of message you wish to receive, specify which data to display, etc.

1. Press the [MENU] key to open the main menu.



Figure 2-5 Main menu

Note: If you press the [MENU] key again at the main menu, the message waiting screen appears.

2. Press ▲ or ▼ to select menu item. As you operate ▲ or ▼, the selected item appears in reverse video. For example, select FUNCTIONS.
3. Press the [ENT] key to open menu selected.

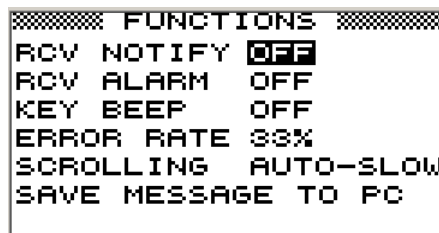

Figure 2-6 FUNCTIONS menu

4. Press ▲ or ▼ to select menu item and press the [ENT] key. For example, select RCV ALARM. Corresponding option menu appears.



Figure 2-7 ON/OFF window

5. Press ▲ or ▼ to select option desired.
6. Press the [ENT] key to register your selection.
7. Press the [MENU] key once to return to the menu or twice to quit the menu.

2.5 Selecting Stations

The STATION SELECTION menu allows you to select what stations to receive, automatically or manually. In the AUTO mode stations are automatically selected according to the distance between own ship and NAVTEX stations. External navigational data is required to use the AUTO mode. If it is not input, all stations are selected. In the MANUAL mode you can select what stations you wish to receive. Default setting is the AUTO mode.

1. Press the [MENU] key to open the main menu.
2. Press ▲ or ▼ to select STATION SELECTION.
3. Press the [ENT] key. The MODE window appears.

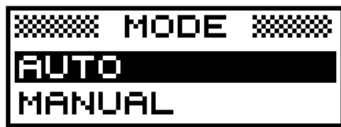

Figure 2-8 MODE window

4. Press ▲ or ▼ to select AUTO or MANUAL as desired.
5. For the AUTO mode, press the [ENT] key to close the menu.
For the MANUAL mode, do the following:
 - a) Press the [ENT] key. The STATION SELECTION menu appears.



Figure 2-9 STATION SELECTION menu

- b) Press ▲ or ▼ to select a station you want to change the current setting.
- c) Press the [ENT] key to show the following window.



Figure 2-10 RECEIVE/IGNORE window

- d) Press ▲ or ▼ to select RECEIVE or IGNORE depending on whether you want to select or deselect the station.
- e) Press the [ENT] key.
- f) Repeat steps b) to e) to select or deselect other stations.
- g) Press the [MENU] key or [DISP] key to close the STATION SELECTION menu.

2.6 Selecting Messages

1. Press the [MENU] key to open the main menu.
2. Press ▲ or ▼ to select MESSAGE SELECTION.
3. Press the [ENT] key to show the MESSAGE SELECTION menu.

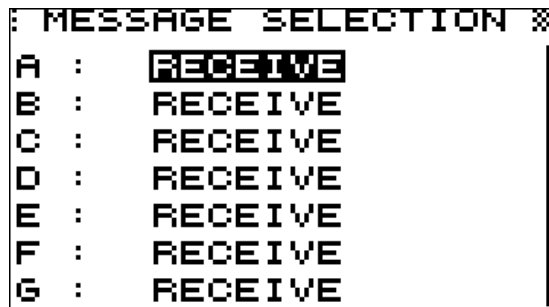

Figure 2-11 MESSAGE SELECTION menu

4. Press ▲ or ▼ to select a message you want to change the current setting.
5. Press the [ENT] key to show the following window.



Figure 2-12 RECEIVE/IGNORE window

6. When you change RECEIVE into IGNORE for message type A, B, D or L, the following window appears to confirm. For all other message types proceed to step 8.

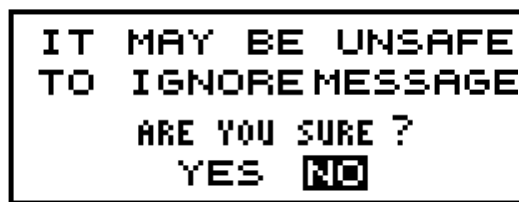

Figure 2-13 Ignore message window

7. Press ◀ or ▶ to select YES or NO. Select YES to change the current setting, or NO not to change.
8. Press the [ENT] key.
9. Repeat steps 4 to 8 to select or deselect other message types.
10. Press the [MENU] key or [DISP] key to close the MESSAGE SELECTION menu.

2.7 Setting Functions (FUNCTIONS menu)

See menu description below for detailed information.

1. Press the [MENU] key to open the main menu.
2. Press ▲ or ▼ to select FUNCTIONS.
3. Press the [ENT] key to display the FUNCTIONS menu.

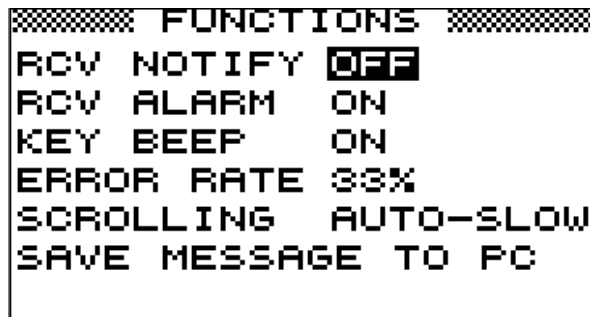

Figure 2-14 FUNCTIONS menu

4. Press ▲ or ▼ to select menu item and press the [ENT] key.
5. Press ▲ or ▼ to select option desired.
6. Press the [ENT] key to register your selection.
7. Press the [MENU] key twice to close the menu.

2.7.1 FUNCTIONS menu description

RCV NOTIFY: The raw NAVTEX signal can be monitored through the monitor speaker by turning RCV NOTIFY on. The default setting is OFF.

RCV ALARM: The audible alarm may be generated when message type A, B, D or L is received. The default setting is ON.

KEY BEEP: The equipment can emit a beep tone when a control is operated. The default setting is ON.

ERROR RATE: When character error occurs due to noise interference during signal propagation, erroneous character is displayed as “*”.

Error Rate means character error rate and is calculated as followed:

Error Rate = number of erroneous characters ÷ total number of characters received × 100 (%)
(Total number of characters includes space, line feed, carriage returns, etc.)

When the character error rate is within the percentage you set (0-39%), the NX-300 displays the message and stores it. When it exceeds the percentage you set, the NX-300 neither displays nor stores the message. You may set the threshold level of character error rate as desired and the default setting is 33%.

SCROLLING: This menu item lets you select how to scroll the message display. The default setting is AUTO-SLOW.

AUTO-SLOW: Long press of ▲ or ▼ scrolls line-by-line slowly automatically. Touch and release ▼ to scroll manually.

AUTO-FAST: Long press of ▲ or ▼ scrolls line-by-line automatically, faster than AUTO-SLOW. Touch and release ▼ to scroll manually.

SKIP-\$\$: The U.S. National Weather Service broadcasts weather information via the U.S. Coast Guard NAVTEX stations. Their messages contain \$\$, the continue indicator. You can quickly jump to the next continue indicator. Long press of ▲ or ▼ skips to \$\$.

SAVE MESSAGE TO PC: Select to download message to a PC. See the next paragraph.

2.7.2 Downloading Messages to a PC

Wiring

Your equipment provides a wiring diagram that shows how to connect to a PC using a DSUB 9-pin connector. Refer to the interconnection diagram for details.

1. Press the [MENU] key to open the main menu.
2. Press ▲ or ▼ to select SYSTEM MENU.
3. Press the [ENT] key to show the SYSTEM MENU.
4. Press ▼ to select WIRING INFO?.
5. Press the [ENT] key to show the wiring info display.

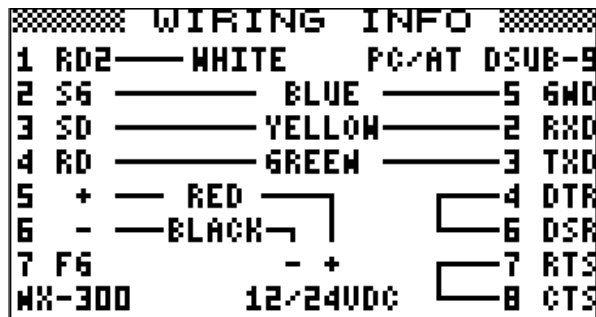

Figure 2-15 Connection to PC using a DSUB 9-pin connector

A DSUB 25-pin (EIA-232) may also be used to make the connection. In this case the wiring diagram is as follows.

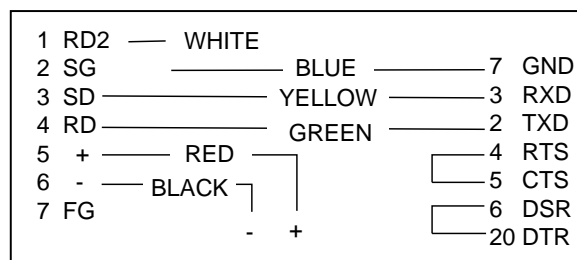

Figure 2-16 Connection to PC using a DSUB 25-pin connector

Setting for communication software on PC

Baud Rate: 4800 bps
Character Length: 8 bit
Stop Bit: 1 bit
Parity: None
X Control: XON/XOFF

Downloading messages to a PC

Set up the computer to receive data. Messages are downloaded to a PC character by character during reception.

To download all messages saved in NX-300, do the following;

1. Press the [MENU] key to open the main menu.
2. Press ▲ or ▼ to select FUNCTIONS.
3. Press the [ENT] key to show the FUNCTIONS menu.
4. Press ▼ to select SAVE MESSAGE TO PC.
5. Press the [ENT] key. The following display appears.



```
SAVE MESSAGE TO PC ?  
ALL MESSAGES WILL  
BE SAVED TO PC.  
  
SET PC PORT TO 4800  
8BIT,P-N,S1,XON/OFF.  
  
CONTINUE?
```

Figure 2-17 SAVE MESSAGE TO PC display

6. Press the [ENT] key.

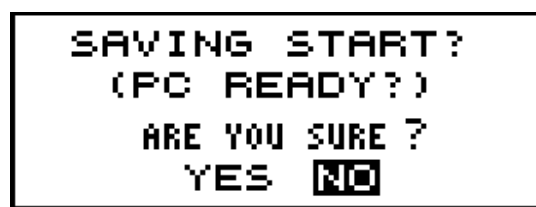

```
SAVING START?  
(PC READY?)  
ARE YOU SURE ?  
YES NO
```

Figure 2-18 SAVING START window

7. Set up the computer to receive data.
8. Press ◀ to select YES and press the [ENT] key.

9. Press the [ENT] key to save. The following messages appear in order.

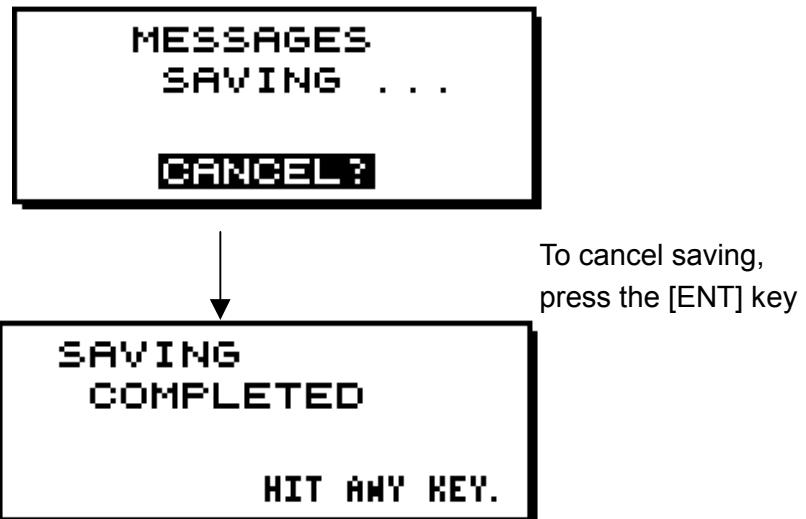

Figure 2-19 SAVING MESSAGES window

10. Press any key to escape.

Note1: No message is received during downloading.

Note2: When a PC or a serial printer is connected to the NX-300, received messages are displayed on a PC or printed on a serial printer but not displayed or saved to the NX-300 in the following cases;

- The NX-300 receives a message it has already saved.
- A message is interrupted to receive.

2.8 Selecting Language

You can select language displayed on the NX-300. Languages are English, French, German, Italian, Spanish, Dutch, Danish, and Portuguese.

1. Press the [MENU] key to open the main menu.
2. Press ▼ to select LANGUAGE.
3. Press the [ENT] key. The following menu appears. (ENG: English, FRA: French, GER: German, ITA: Italian, SPA: Spanish, DUT: Dutch, DEN: Danish, POR: Portuguese)



Figure 2-20 LANGUAGE menu

4. Use the Omnipad to select language desired.
5. Press the [ENT] key to register your selection and press the [MENU] key to close the menu.

2.9 Displaying Messages

The NX-300 automatically saves and stores up to 132 received messages (However, the memory capacity is limited to 28,000 characters). If memory of the NX-300 is full, messages are deleted on order of time.

1. Press the [DISP] key to show the received messages log. Messages (numbers) are arranged in the order received from latest to earliest, Left to right.

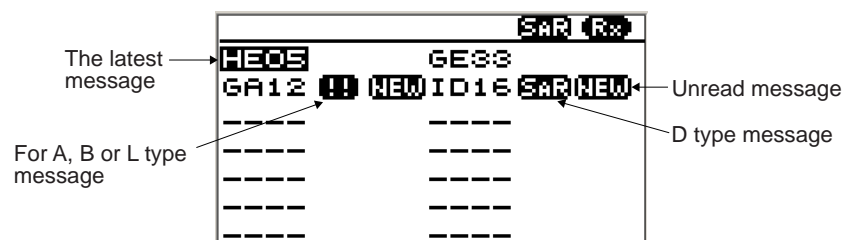

Figure 2-21 Received messages log

2. Operate the Omnipad to select the message to display. If more than 15 messages are saved, the scroll bar appears at the right side of the display. Press ▲ or ▼ to scroll the display.
3. Press the [ENT] key to display the message selected.

Note: If you want to see the received frequency (518 kHz or 490 kHz) also, change the window mode as shown on page 4-2.

2.10 Sample Messages

When message is displayed, press ▲ or ▼ to scroll message and press ◀ or ▶ to display the other message. When the oldest or newest message is displayed, the beep sounds.

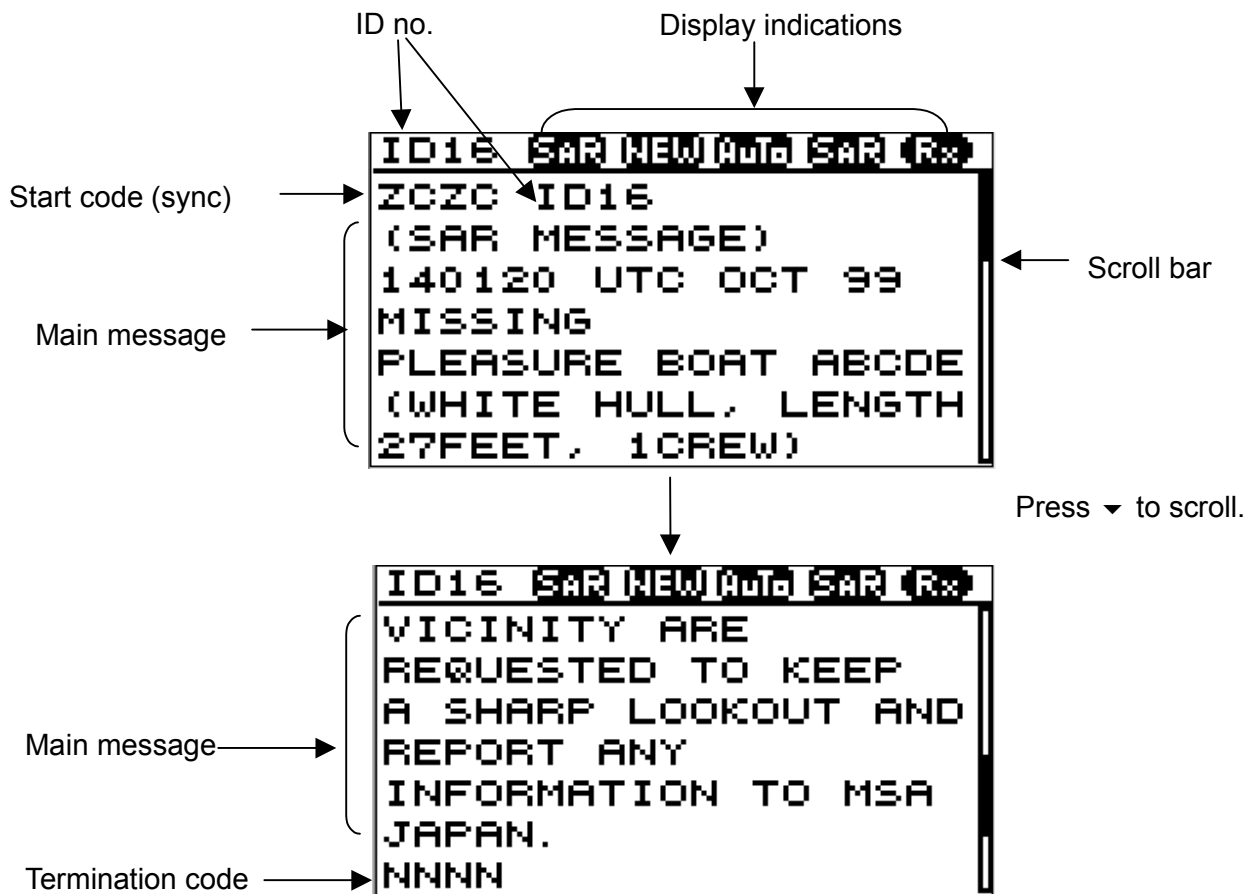

Figure 2-22 Sample messages

2.11 Displaying Navigation Data

With navigation data input the NX-300 can display navigation data, in addition to its primary function.

1. Press the [DISP] key to display the receiving messages log.
2. Press the [DISP] key again to display navigation data.

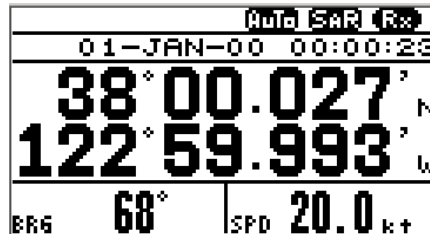
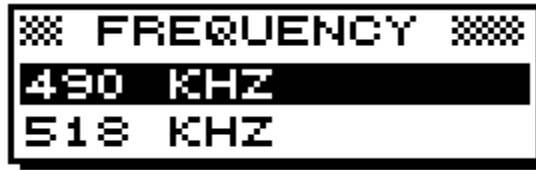

Figure 2-23 Nav data display

3. To return to the receiving message log, press the [DISP] key again.

2.12 Selecting Receive Frequency

1. Press the [FREQ] key to show the frequency window.



(Default setting is 518 kHz)

Figure 2-24 Frequency window

2. Press ▲ or ▼ to select receive frequency as appropriate.
3. Press the [ENT] key to close the frequency window.

3. SYSTEM MENU

3.1 Units of Measurement

When navigational data is fed to the NX-300, you can select units of distance and speed to use. Distance/speed can be displayed in nautical miles/knots, kilometers/kilometers per hour, or miles/ miles per hour. The default setting is nautical miles/knots.

1. Press the [MENU] key to open the main menu.
2. Press ▲ or ▼ to select SYSTEM MENU.
3. Press the [ENT] key. The SYSTEM MENU appears.

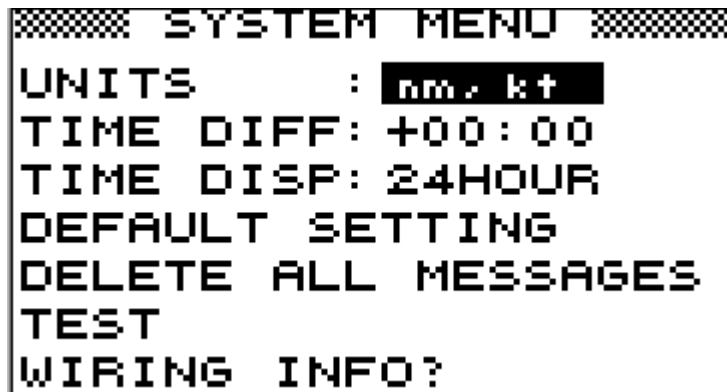

Figure 3-1 SYSTEM MENU

4. Press the [ENT] key. The following window appears.



Figure 3-2 UNITS window

5. Press ▲ or ▼ to select combination desired; nm, kt; km, km/h; mi, mi/h.
6. Press the [ENT] key.
7. Press the [MENU] key or [DISP] key to close the SYSTEM MENU.

3.2 Time Difference (using local time)

GPS uses UTC time. If a GPS receiver feeds nav data to the NX-300 and you would rather use local time, enter the time difference (range: -13:30 to +13:30) between local time and UTC time.

1. Press the [MENU] key to open the main menu.
2. Press ▲ or ▼ to select SYSTEM MENU.
3. Press the [ENT] key to open the SYSTEM MENU.

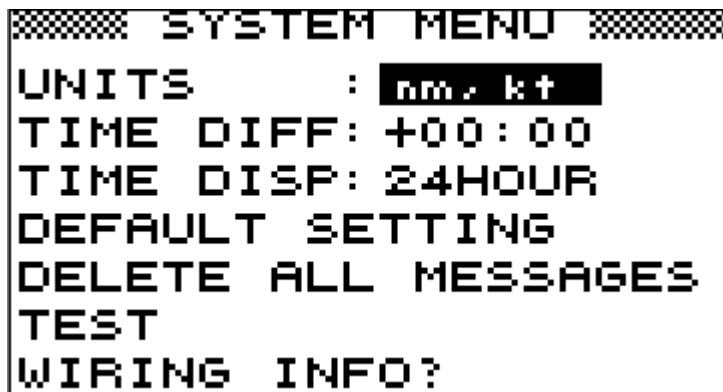

Figure 3-3 SYSTEM MENU

4. Press ▼ to select TIME DIFF.
5. Press the [ENT] key. A cursor circumscribes + or -. This cursor appears whenever selected data can be changed with Omnipad.
6. Press ▲ or ▼ to display + or -.
7. Press ▶ to move the cursor to the next column.
8. Press ▲ or ▼ to select number desired.
9. Repeat steps 7 and 8 to complete.
10. Press the [ENT] key.
11. Press the [MENU] key or [DISP] key to close the SYSTEM MENU.

3.3 Time Display

When navigational data is fed to the NX-300, you may display the time in 12-hour or 24-hour notation. The default setting is 24-hour notation. AM or PM is shown when 12-hour notation is selected.

1. Press the [MENU] key to open the main menu.
2. Press ▲ or ▼ to select SYSTEM MENU.
3. Press the [ENT] key. The SYSTEM MENU appears.
4. Press ▼ to select TIME DISP.
5. Press the [ENT] key. The following window appears.



Figure 3-4 TIME DISP window

6. Press ▲ or ▼ to select 12HOUR or 24HOUR as appropriate.
7. Press the [ENT] key.
8. Press the [MENU] key or [DISP] key to close the SYSTEM MENU.

3.4 Default Setting

This function restores all default settings.

1. Press the [MENU] key to open the main menu.
2. Press ▲ or ▼ to select SYSTEM MENU.
3. Press the [ENT] key to show the SYSTEM MENU.
4. Press ▼ to select DEFAULT SETTING.
5. Press the [ENT] key. The following window appears.

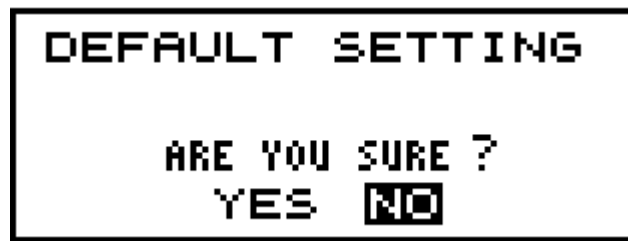

Figure 3-5 DEFAULT SETTING window

6. Press ◀ to select YES. If you want to cancel, press the [ENT] key to select NO before pressing ◀.
7. Press the [ENT] key.
8. Press the [MENU] key or [DISP] key to close the SYSTEM MENU.

3.5 Delete All Messages

This function deletes all messages NX-300 saves.

1. Press the [MENU] key to open the main menu.
2. Press ▲ or ▼ to select SYSTEM MENU.
3. Press the [ENT] key to show the SYSTEM MENU.
4. Press ▼ to select DELETE ALL MESSAGES.
5. Press the [ENT] key. The following window appears.



Figure 3-6 DELETE ALL MESSAGES window

6. Press ◀ to select YES.
7. Press the [ENT] key.
8. Press the [MENU] key or [DISP] key to close the SYSTEM MENU.

3.6 User Display of Navigation Data

The NX-300 can function as nav data display when connected to navigation equipment.

You may choose what data to display in the three cells below the date and time indications on the nav data display. The choices of data are speed, course, range, bearing, power source voltage and position in latitude and longitude (not available for “LEFT” or “RIGHT”).

01-JAN-00		15:37:40	
LARGE			
LEFT		RIGHT	

Figure 3-7 Location of nav data indications

1. Press the [MENU] key to open the main menu.
2. Press ▼ to select USER DISPLAY.

- Press the [ENT] key to show the USER DISPLAY menu. The cursor is now on the LARGE field. LARGE means the center indication on the nav data display.

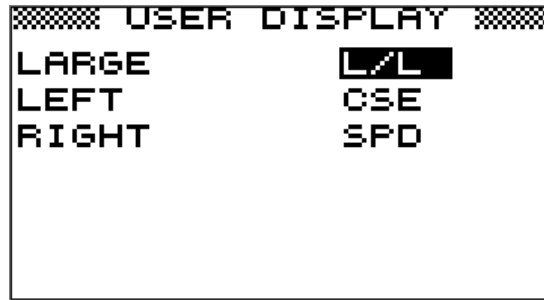

Figure 3-8 USER DISPLAY

- Press the [ENT] key. The following window appears.

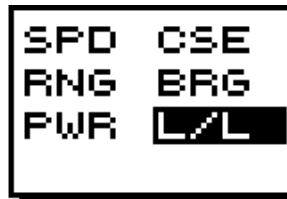

Figure 3-9 Options for LARGE window

- Operate the Omnipad to select item desired. (SPD: Speed, CSE: Course, RNG: Range to destination, BRG: Bearing to destination, PWR: Power source voltage, L/L: position in latitude and longitude)
- Press the [ENT] key.
- Select the items LEFT and RIGHT and set their options like you did for LARGE, referring to Figure 3-12 for location of indications.

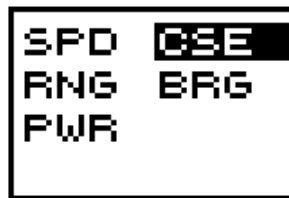

Figure 3-10 Options for LEFT, RIGHT

- Press [DISP] key twice to display the navigation data.

The figure below shows display appearance for the setting shown in Figure 3-8.

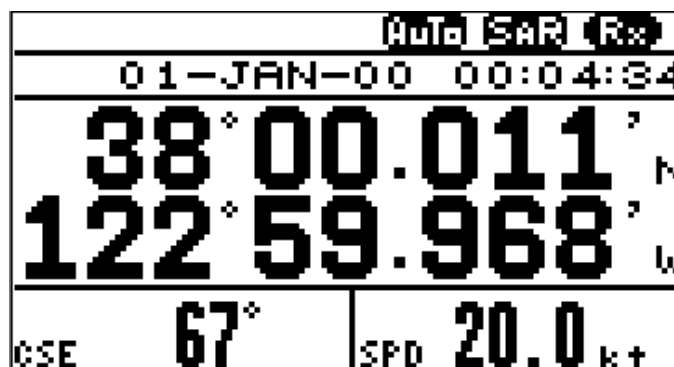

Figure 3-11 Nav data display

This page is intentionally left blank.

4. OTHER FUNCTIONS

4.1 DEMO Mode

The DEMO mode provides simulated operation of this unit. Connection of antenna is not necessary. You may select stations and messages manually or automatically and demo messages are received. All controls are operative.

Note: Turning on the DEMO mode erases all messages.

Press the [PWR] key while pressing ▶ to turn the power on. "SET DEMO MODE!" appears momentarily. "DEMO" appears at the top of the screen when the DEMO mode is active.

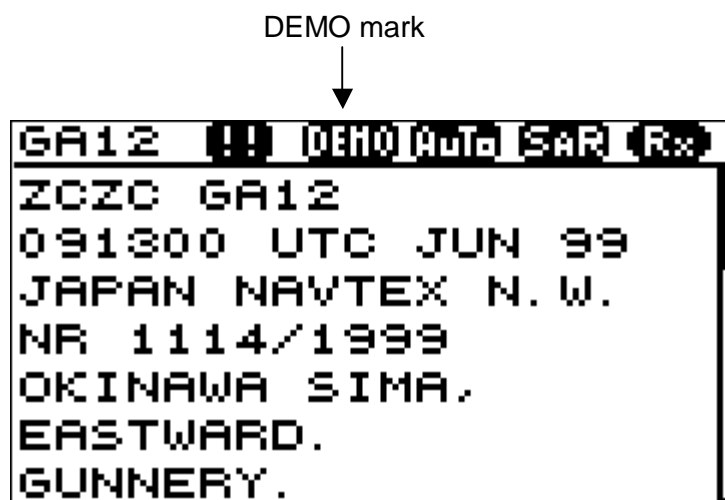

Figure 4-1 Message display

To escape the DEMO mode, press the [PWR] key while pressing ▶. "RESET DEMO MODE!" appears momentarily.

4.2 VIEW Mode

The NX-300 ordinarily displays messages in their entirety. The VIEW mode, however displays messages character by character.

Press the [PWR] key while pressing ▼ to turn the power on. "SET VIEW MODE!" appears momentarily. "VIEW" is displayed at the upper left corner of the display.

To quit the VIEW mode, repeat above procedure. "RESET VIEW MODE!" appears.

4.3 All Clear

This function deletes all messages and restores default settings. When the NX-300 is first installed, you should clear all data.

Press the [PWR] key while pressing ▲ to turn the power on. "RESET BACKUP DATA!" appears momentarily while data is being cleared. Then, all default settings are restored.

4.4 Changing Received Message Log Window

You can show received frequency on the received message log as shown below.

1. Press the [PWR] key while pressing ◀ to turn the power on and release the keys after display appears.
2. Press the [DISP] key to show the received message log. The received frequencies (518 kHz and 490 kHz) are displayed on the window.

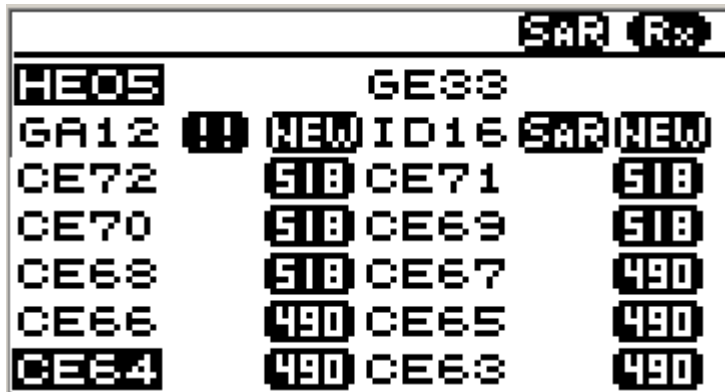

The screenshot shows a received message log window with a title bar that reads "SAR R:". The log contains the following entries:

Call Sign	Frequency
HE05	GE33
GA12 !!	NEW ID16 SAR NEW
CE72	518 CE71 518
CE70	518 CE69 518
CE68	518 CE67 490
CE66	490 CE65 490
CE64	490 CE63 490

Figure 4-2 Received message log

3. To restore it, do step 1.

5. MAINTENANCE & TROUBLESHOOTING

WARNING

Do not open the equipment.

Only qualified personnel should work inside the equipment. Further, watertightness may be reduced.

5.1 Maintenance

Check the following points regularly to maintain performance:

- Check that connectors on the rear panel are firmly tightened and free of rust.
- Check that the ground system is free of rust and the ground wire is tightly fastened.
- Check that battery terminals are clean and free of rust.
- Check the antenna for damage. Replace if damaged.
- Dust and dirt on the keyboard and display screen may be removed with a soft cloth. Do not use chemical cleaners to clean the equipment; they may remove paint and markings.

5.2 Diagnostic Test

The diagnostic test checks ROM, RAM, data port, battery, keyboard and LCD for proper operation and displays program numbers.

1. Press the [MENU] key to open the main menu.
2. Press the ▲ or ▼ to select SYSTEM MENU.
3. Press the [ENT] key to show the SYSTEM MENU.
4. Press ▲ or ▼ to select TEST.
5. Press the [ENT] key. You are asked if you are ready to start the test.

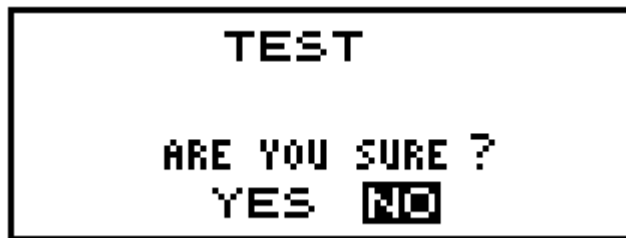

Figure 5-1 TEST window

6. Press the ◀ to select YES.

7. Press the [ENT] key to start the test. The equipment checks ROM, RAM, SIO and internal battery, and the results are individually displayed as OK or NG (No Good). Program numbers appear at the bottom of the display.

Note 1: SIO requires a special connector to check. "03" appears as the result when no connector is connected.

Note 2: CNT is the number of times test has been consecutively executed.

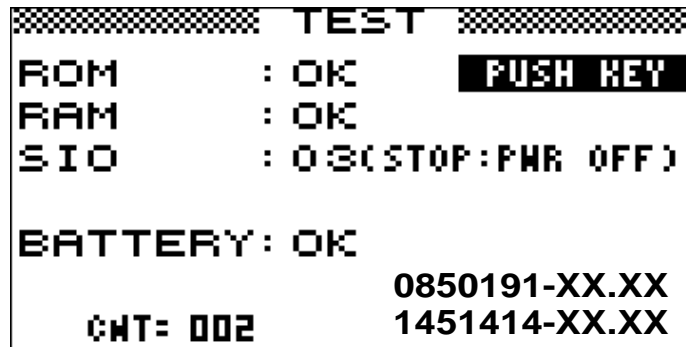

XX: Program version no.

Figure 5-2 TEST display

After the equipment has checked the items shown in Figure 5-2, a beep sounds and the message PUSH KEY appears at the top right-hand corner.

8. Press each key one by one. The name of the key pressed momentarily appears at the top of right-hand corner if the key is functioning properly.

Note: If no key is pressed within approx. five seconds, the equipment automatically displays the following message to inform you that it is now going to check the LCD.

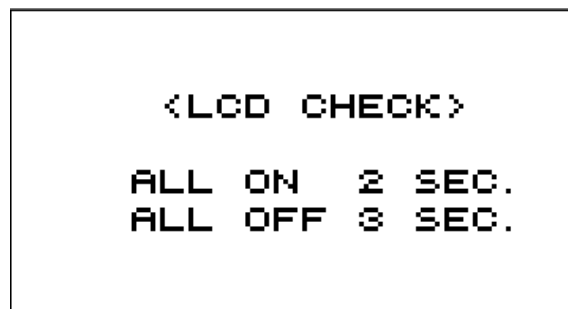

Figure 5-3 LCD CHECK display

9. The test repeats. Turn off the power to stop the test.

5.3 When the Battery Icon Appears

A lithium battery (type: CR2354-1F2, code no.: 000-142-305) is installed on the circuit board inside the display unit, and it preserves data when the power is turned off. The life of the battery is about 5-10 years. Its voltage is checked when the power is turned on. When its voltage is low the battery icon appears on the display to alert you. When this happens, contact your dealer to request replacement of the battery.

Note: When the battery is dead, all default settings are restored.

5.4 Replacement of Fuse

The 1 A fuse in the snap-in fuse holder on the power cable protects the equipment from equipment fault and reverse polarity of the ship's mains. If the fuse blows find out the cause before replacing it. If the fuse blows again after replacement, contact a FURUNO agent or dealer for advice. Use only a 1 A fuse – use of a different fuse will damage the equipment and void the warranty.



CAUTION

Use the proper fuse.

Use of a wrong fuse can cause fire or equipment damage.

This page is intentionally left blank.

6. INSTALLATION

6.1 Installation of Display Unit

Mounting considerations

The display unit can be installed on a tabletop, on the overhead, or in a panel (optional flush mounting kit required). Refer to the outline drawings at the end of this manual for installation instructions. When selecting a mounting location, keep in mind the following points:

- Locate the unit away from exhaust pipes and vents.
- The unit is waterproof thus it can be installed outdoors. However, locate it of direct sunlight, (or in a suitable, ventilated enclosure) to prevent heat which can build up inside the cabinet.
- The mounting location should be well ventilated.
- Mount the unit where shock and vibration are minimal.
- Allow sufficient maintenance space at the sides and rear of the unit and leave sufficient slack in cables, to facilitate maintenance and servicing.
- Observe the following compass safe distances to prevent deviation of a magnetic compass; Standard compass, 0.5 m, Steering compass, 0.3 m.
- After you install this equipment, perform All Clear as in paragraph 4.3 on page 4-1.

Tabletop overhead mounting

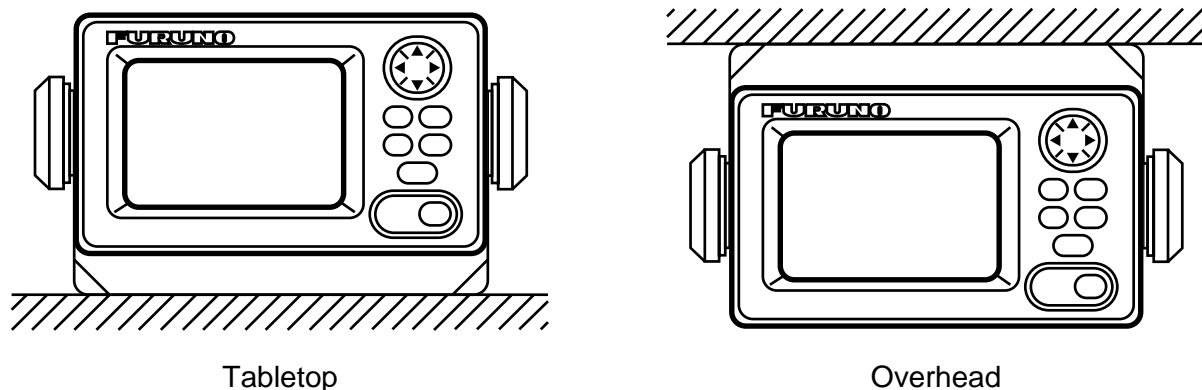

Figure 6-1 Tabletop and overhead mounting methods

Flush mounting

There are two types of flush mounting kits. For details, see the outline drawings at the end of this manual.

6.2 Installation of Antenna Unit

Mounting considerations

Install the antenna unit referring to the antenna installation diagram at the end of this manual. When selecting a mounting location for the antenna unit, keep in mind the following points:

- Do not shorten the antenna cable (10 m cable fitted to the antenna).
- The length of the whip antenna for the NX-3E should be no longer than 1.2 m and no larger than 5 mm in diameter to prevent antenna damage. Do not use a 2.5 m whip antenna. Use spring washer (supplied) for whip antenna.
- Do not install the antenna unit within beamwidth of the radar.
- If the antenna cable is to be passed through a hole which is not large enough to pass the connector, you may unfasten the connector with a needle nose pliers and 3/8-inch open-end wrench. Refasten it as shown in Figure 6-2, after running the cable through the hole.
- If you install the antenna unit except the NX-3E and the NX-3H, contact your dealer.

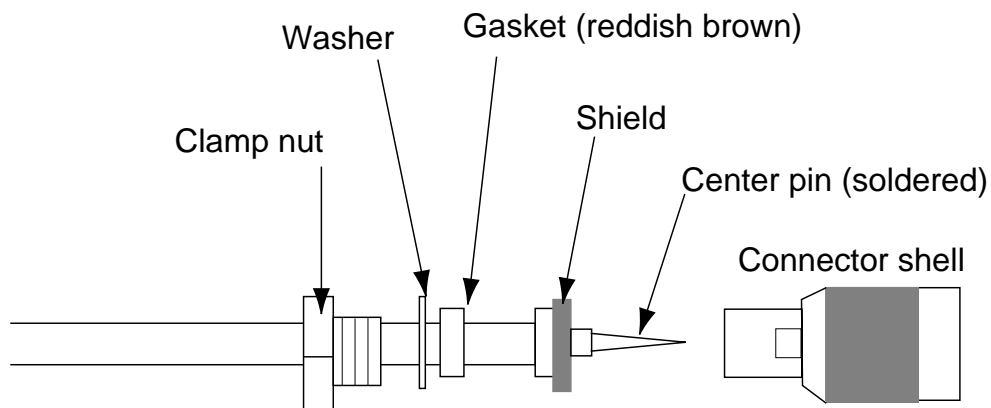

Figure 6-2 How to assemble the connector

6.3 Wiring

The figure below shows where to connect cables on the rear of the display unit.

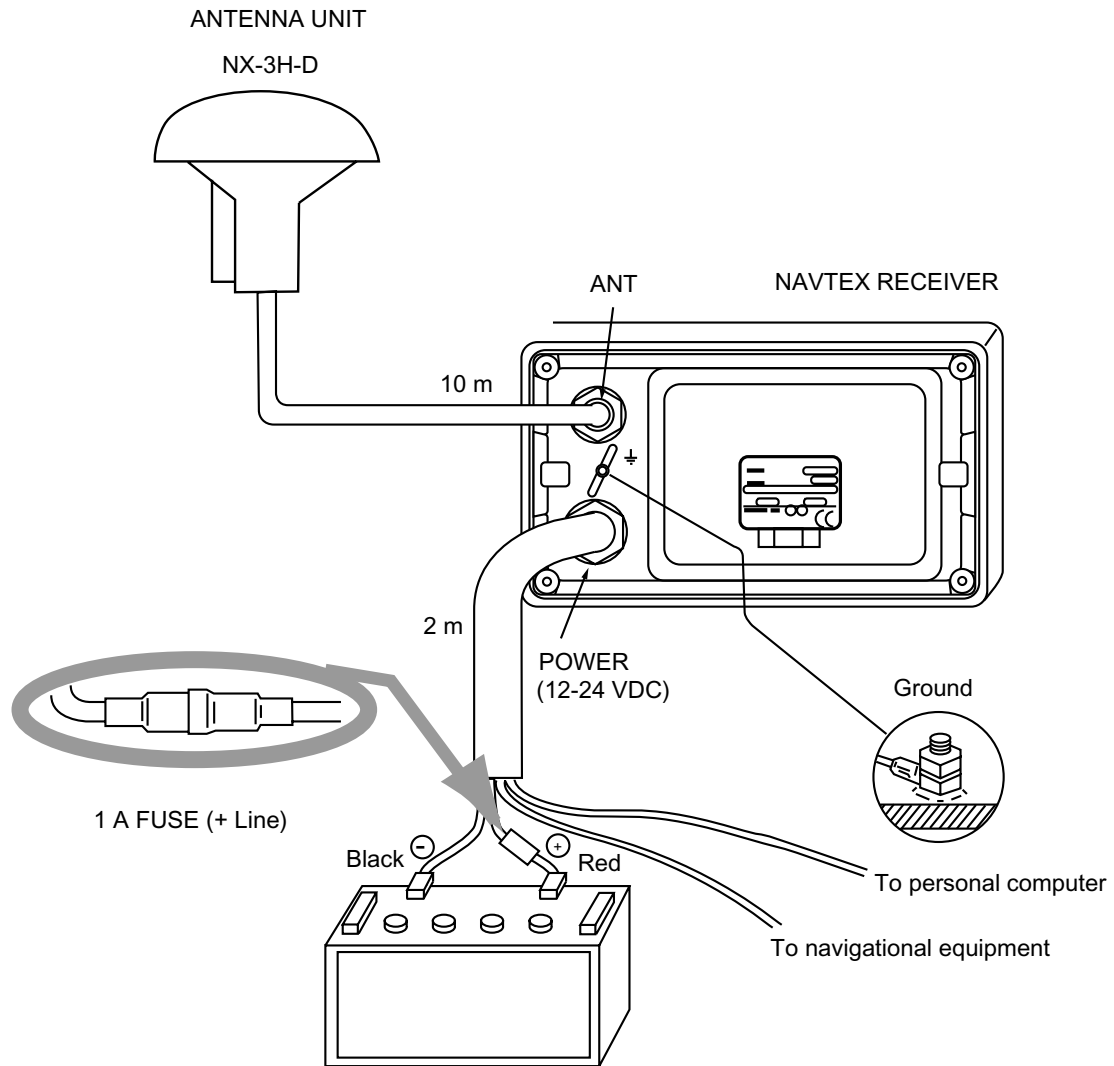

Figure 6-3 Wiring

Note: The fuse holder contains a spring that fixes the fuse. To prevent detachment of the spring, which would cause loss of power, tie the line as shown in Figure 6-4.

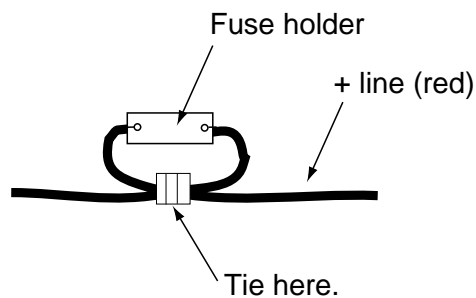

Figure 6-4 How to fix spring in fuse holder

Grounding

- The ground wire (local supply) should be 1.25 sq or larger for Navtex Receiver. The ground wire should be as short as possible.
- The signal ground and frame ground are separated, however the power line is not isolated. Therefore, if connecting other equipment which has signal ground connected to frame ground, the earth lamp will light. Especially, for positive ground battery separate the frame ground of the external equipment from the earth. If not, the equipment may be damaged.

External equipment

The power supply port is commonly used for connection of external equipment such as navigation equipment or a PC. Refer to the interconnection diagram on page S-1 for connection.

6.4 Interfacing

This equipment can receive navigation data in RS-232C format. For example, it can receive position data from GPS navigator GP-31/GP-36 for display on its screen. If you want to connect equipment which outputs data in a format other than RS-232C, a level converter is required for interface. Consult FURUNO dealer for details.

Input data sentence description

- GGA: GPS position fixing condition (time of fix, latitude, longitude, receiving condition, number of satellites used, DOP)
- GLL: Latitude and longitude
- RMB: Generic navigational information (cross track error, steering direction, starting waypoint no., destination waypoint no., latitude and longitude of starting waypoint, latitude and longitude of destination waypoint, range and bearing to waypoint, range and bearing from present position to destination waypoint, velocity to destination, arrival alarm)
- ZDA: Time and date

MENU TREE

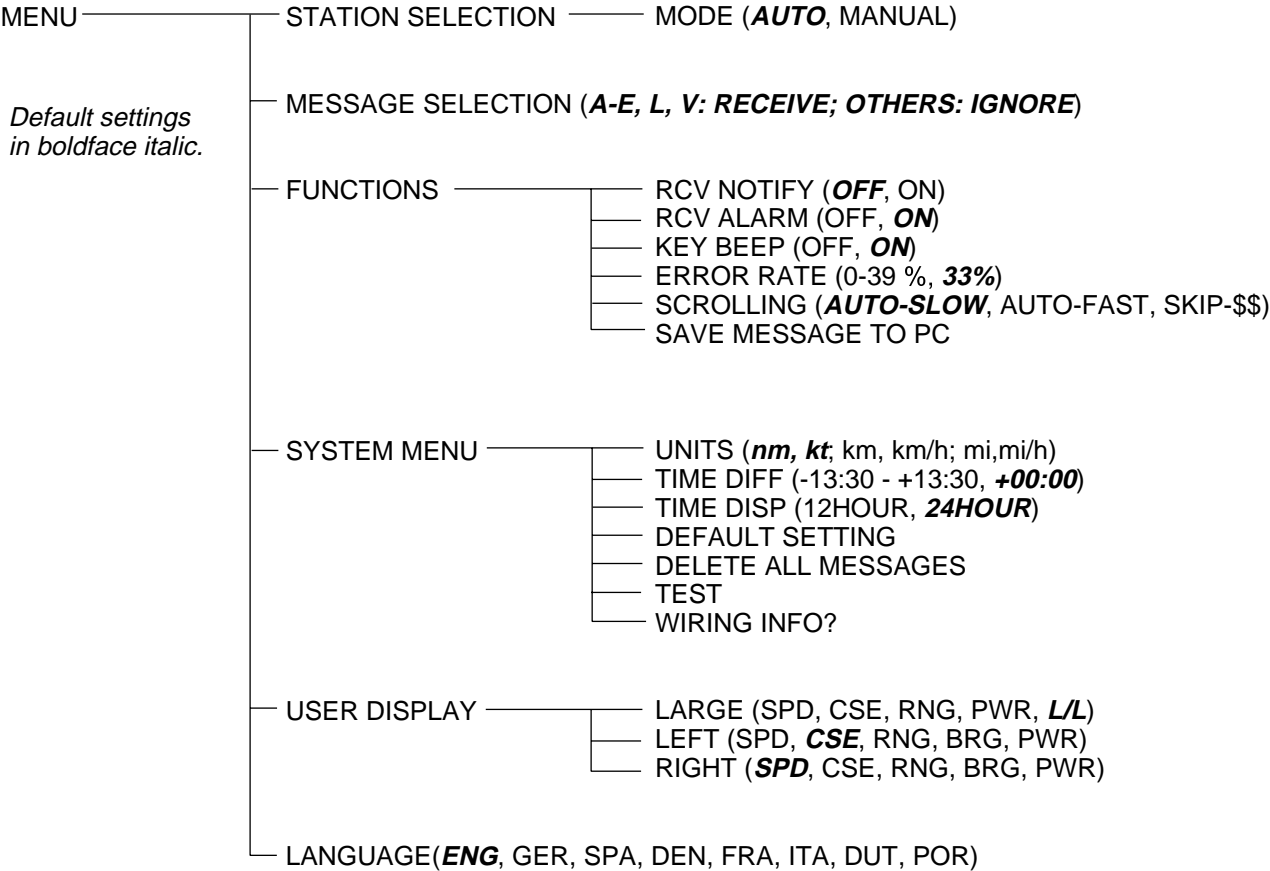

**SPECIFICATIONS OF NAVTEX RECEIVER
NX-300**

1 NAVTEX RECEIVER

- 1.1 Receiving Frequency 518 kHz or 490 kHz
- 1.2 Mode of Reception F1B
- 1.3 Sensitivity 2 μ V e.m.f. (50 ohms), 4% error rate
- 1.4 Message Category
 - A: Navigation warning
 - B: Meteorological warning
 - C: Ice report
 - D: Search and rescue information/ piracy and armed robbery
 - E: Meteorological forecast
 - F: Pilot message
 - G: Decca message
 - H: Loran-C message
 - I: Omega message
 - J: Differential omega message
 - K: Other electronic navigational aid and system message
 - L: Navigational warning (additional)
 - M to Y: Reserved – presently not used
 - V: Notice to Fishermen (US only)
 - Z: QRU (no message on hand)

2 DISPLAY SECTION

- 2.1 Display System 4.5-inch (95 x 60 mm) Monochrome LCD, 120 x 64 pixels
- 2.2 Display Modes Message Selection Mode, NAV Data Mode, Message Display Mode
- 2.3 Message Storage 28,000 Characters

3 ANTENNA UNIT

- 3.1 Selectable Antenna NX-3H-D: H-field antenna for NX-300-H-D
Others: Local supply antenna for NX-300-N-D
- 3.2 Input Impedance 50 ohms
- 3.3 Power supply +5.0 VDC

4 INTERFACE

- 4.1 Input Data NMEA0183 Ver.1.5/2.0, RS-232C, 4800 bps
GGA, GLL, RMB, ZDA
- 4.2 Output Data Message data for personal computer, RS-232C, 4800 bps
Data length: 8, Stop bit: 1, Parity: None
T/R Code: CR+LF, XON/XOFF Control, Local echo: ON

5 POWER SUPPLY

12-24 VDC: 180-90 mA

6 ENVIRONMENTAL CONDITION

- | | | |
|-----|---------------------|---|
| 6.1 | Ambient Temperature | Antenna unit: -25°C to +70°C
Navtex receiver: -15°C to +55°C |
| 6.2 | Relative Humidity | 95% at 40°C |
| 6.3 | Water proofing | Antenna unit: IEC-IPX6
Navtex receiver: IEC-IPX5 |
| 6.4 | Vibration | ±1 mm ±10%, 5 to 13.2 Hz,
Maximum acceleration 7 m/s ² , 13.2 to 100 Hz (IEC 60945) |

7 COATING COLOR

- | | | |
|-----|-----------------|----------------------------------|
| 7.1 | Navtex receiver | Chassis: 2.5GY5/1.5, Panel: N3.0 |
| 7.2 | Antenna Unit | N9.5 |

This page is intentionally left blank.

PACKING LIST

NX-300-H-D

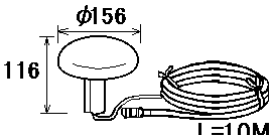
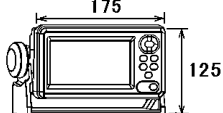
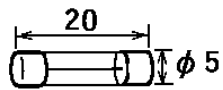
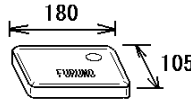
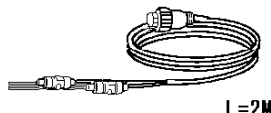
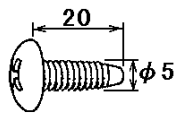
NAME	OUTLINE	DESCRIPTION/CODE No.	Q'TY
ユニット UNIT			
空中線部 ANTENNA UNIT		NX-3H-D 000-059-204	1
ナビテックス受信機 NAVTEX RECEIVER		NX-300-D 000-059-205	1
予備品 SPARE PARTS			
ヒューズ FUSE		FGMB 1A 125V 000-114-805	2
付属品 ACCESSORIES FP14-02801			
保護カバー COVER		20-016-1091-2 100-297-032	1
工事材料 INSTALLATION MATERIALS			
ケーブル組品MJ CABLE ASSY.		MJ-A7SPF0009-020 000-145-612	1
+トラスタップネジ +TAPPING SCREW		5X20 SUS304 1ヶ 000-802-081	4

(略図の寸法は、参考値です。 DIMENSIONS IN DRAWING FOR REFERENCE ONLY.)

PACKING LIST

NX-300-N-D

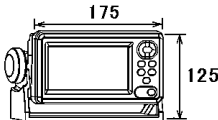
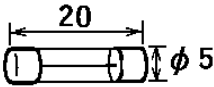
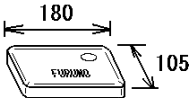
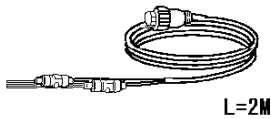
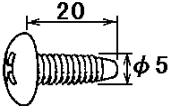
NAME	OUTLINE	DESCRIPTION/CODE No.	Q'TY
ユニット UNIT			
ナビテックス受信機 NAVTEX RECEIVER		NX-300-D 000-059-205	1
予備品 SPARE PARTS			
ヒューズ FUSE		FGMB 1A 125V 000-114-805	2
付属品 ACCESSORIES FP14-02801			
保護カバー COVER		20-016-1091-2 100-297-032	1
工事材料 INSTALLATION MATERIALS			
ケーブル組品MJ CABLE ASSY.		MJ-A7SPF0009-020 000-145-612	1
+トラスタップネジ +TAPPING SCREW		5X20 SUS304 1シュ 000-802-081	4

(略図の寸法は、参考値です。 DIMENSIONS IN DRAWING FOR REFERENCE ONLY.)

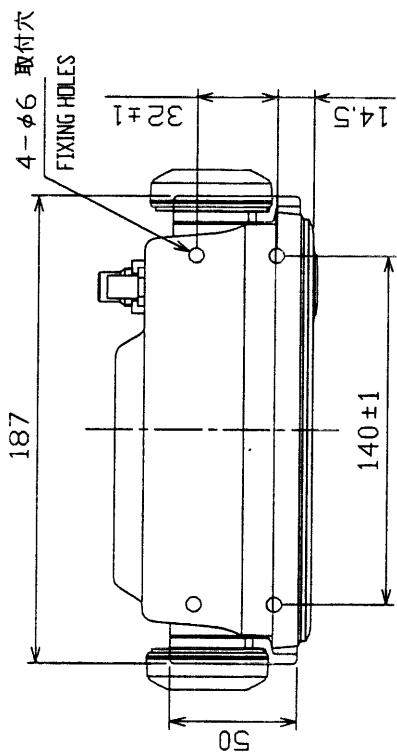

矢視A VIEW A

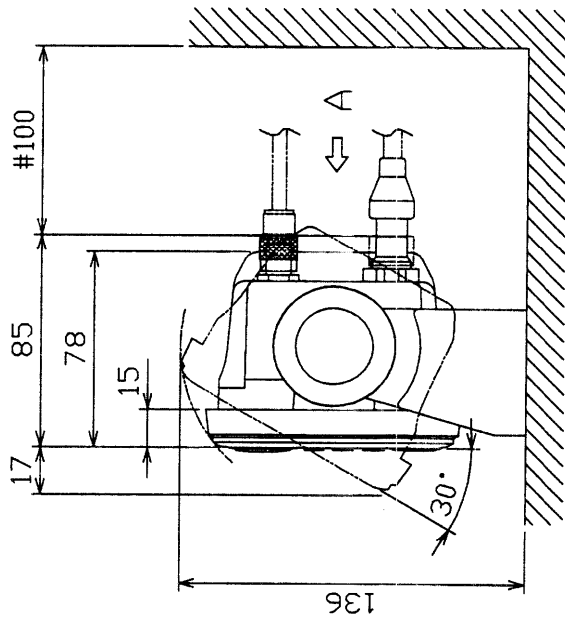

寸法区分 (mm) DIMENSION	公差 (mm) TOLERANCE
L ≤ 50	±1.5
50 < L ≤ 100	±2.5
100 < L ≤ 500	±3

型式銘板
NAMEPLATE

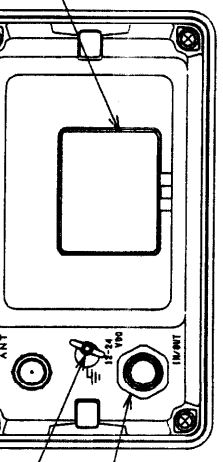

7-入端子
GND TERMINAL
電源コネクタ
SOURCE

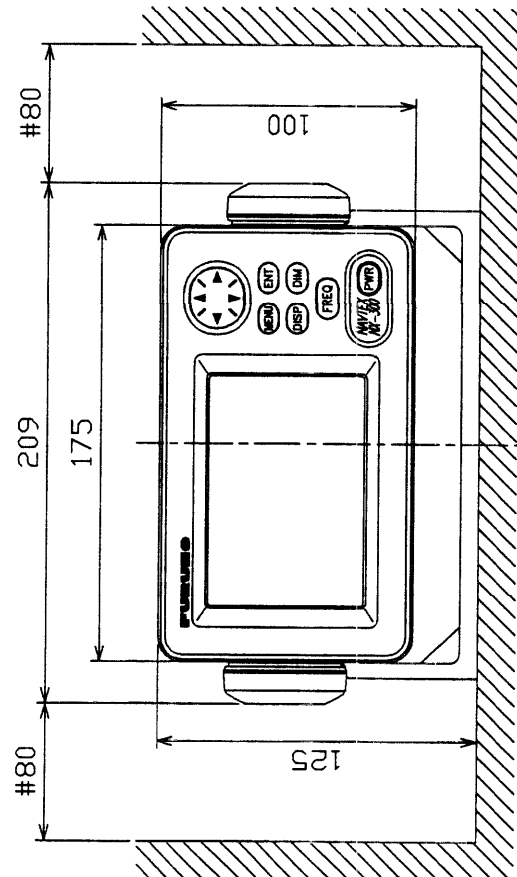

注 記

- 1) 装備ケーブルはサービス時、本体を前方に十分引き出せるよう余裕を持たせること。
- 2) 取付用ネジはトラスタツピングネジ呼び径5×20を使用のこと。
- 3) 指定外寸公差は表1による。
- 4) #印寸法は最小サービス空間寸法とする。

NOTE

1. KEEP SUFFICIENT CABLE LENGTH BEHIND THE UNIT.
2. USE TAPPING SCREWS 5 x 20 FOR FIXING THE UNIT.
3. TABLE 1 INDICATES TOLERANCE OF DIMENSIONS.
4. # RECOMMENDED SERVICE CLEARANCE.

DRAWN May 9 '01 T. YAMASAKI	TITLE NX-300-D
CHECKED May 10 '01 Y. Kuroi	名称 受信機 (卓上装備)
APPROVED May 10 '01 S. Yoshida	外寸図
SCALE 1/3	NAME RECEIVER UNIT (DESKTOP MOUNT)
DWG. No. C5629-G01-B	OUTLINE DRAWING

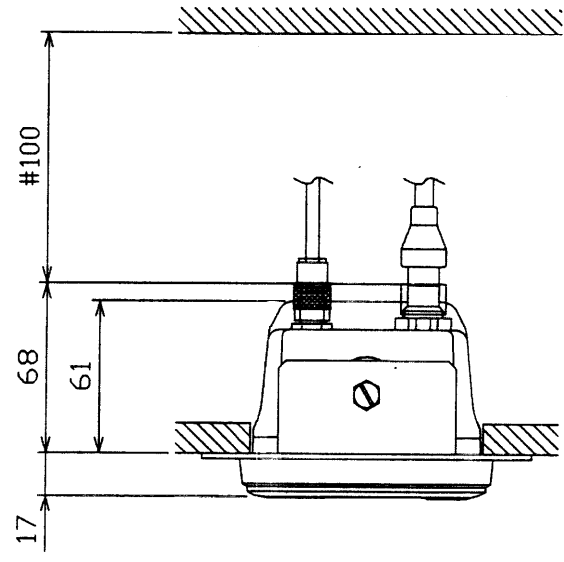
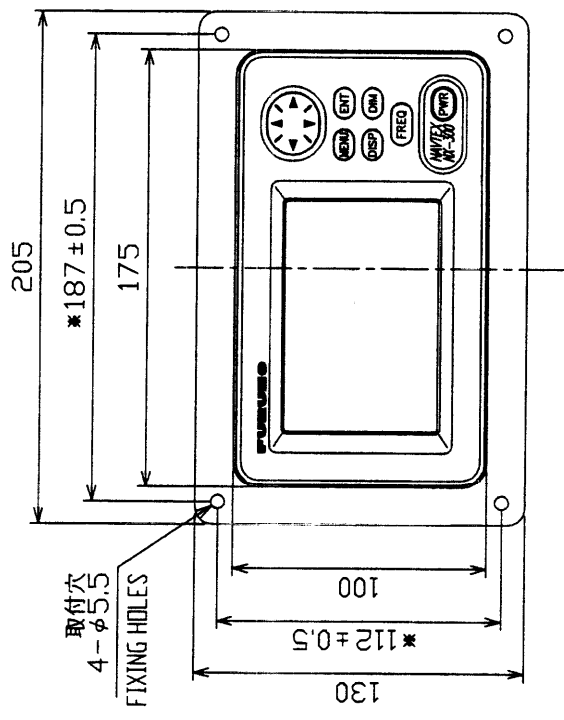

寸法区分 (mm) DIMENSION	公差 (mm) TOLERANCE
L ≤ 50	±1.5
50 < L ≤ 100	±2.5
100 < L ≤ 500	±3

表 1
TABLE 1

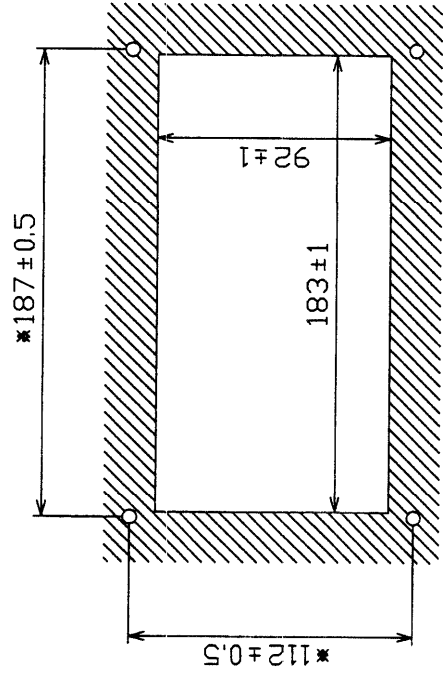

取付穴寸法図 (参考図)
CUTOUT DIMENSIONS

- 注 記
- 1) *印寸法は取付穴位置寸法とする。
 - 2) 取付用ネジはタッピングネジ呼び径5×20を使用のこと。
 - 3) 指定外の寸法公差は表1による。
 - 4) #印寸法は最小サービスイ間寸法とする。

NOTE

1. "*" INDICATES DIMENSION OF FIXING HOLES PITCH.
2. USE TAPPING SCREWS 5 x 20 FOR FIXING THE UNIT.
3. TABLE 1 INDICATES TOLERANCE OF DIMENSIONS.
4. #: RECOMMENDED SERVICE CLEARANCE.

DRAWN No. 9 '01 T. YAMASAKI	TITLE NX-300-D
CHECKED Mitsuyoshi Y. Shimizu	名 * 受信機 (埋込装備 F)
APPROVED Mitsuyoshi Y. Shimizu	外寸図
SCALE 1/3 MASS 0.67 kg	NAME RECEIVER UNIT (FLUSH MOUNT F)
JWG No. C5629-G03-B	08-021-111G-0
	OUTLINE DRAWING

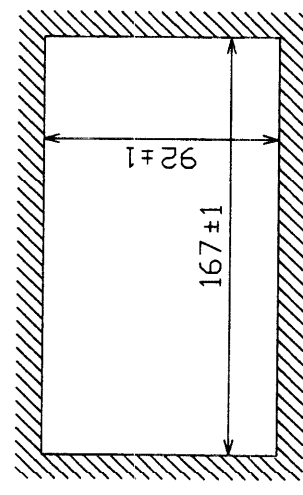
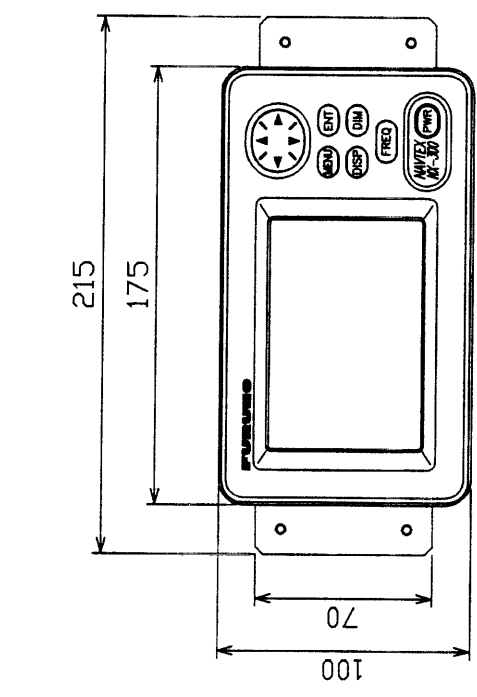

取付穴寸法図 (参考図)
CUTOUT DIMENSIONS

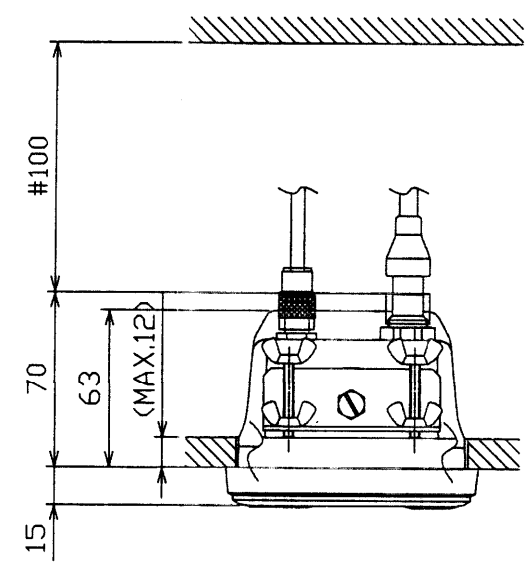

寸法区分 (mm) DIMENSION	公差 (mm) TOLERANCE
$L \leq 50$	± 1.5
$50 < L \leq 100$	± 2.5
$100 < L \leq 500$	± 3

表 1
TABLE 1

注 記 1) 指定外の寸法公差は表 1 による。
2) # 印寸法は最小サージス空間寸法とする。

NOTE 1. TABLE 1 INDICATES TOLERANCE OF DIMENSIONS.
2. #: RECOMMENDED SERVICE CLEARANCE.

DRAWN May 9 '01 T. YAMASAKI	TITLE NX-300-D
CHECKED May 10 '01 Y. Kishi	名称 受信機 (埋込装置 S)
APPROVED May 10 '01 S. Yoshida	外寸図
SCALE 1/3	NAME RECEIVER UNIT (FLUSH MOUNT S)
DESIGNER C5629-G04-B	OUTLINE DRAWING
	08-021-121G-0

A) マストへの取付け MAST MOUNTING

a) マスト取付金具CP20-0111(工事材料)でマストに固定する。
USE MAST MOUNTING KIT CP20-0111.

b) パイプのみを使うとき
USE A PIPE ONLY.

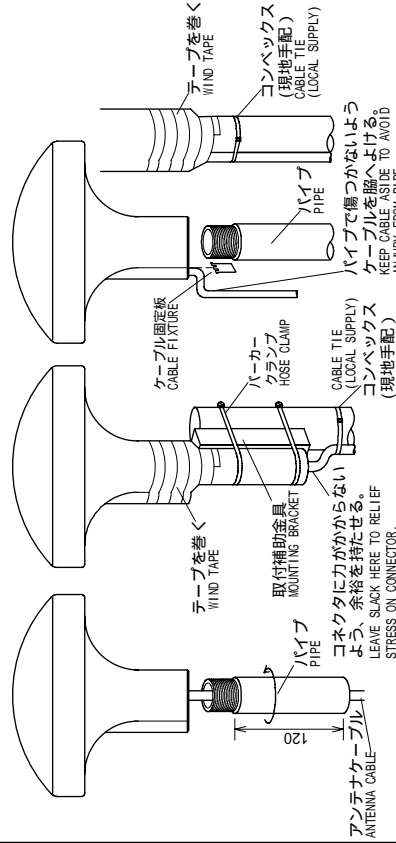

B) スタンションやパルピットにつけるとき HANDRAIL MOUNTING

レール用アンテナベース No.13-RC5160 (取付可能レール直径: 19~32)
(コード番号: 000-806-114)

USE HANDRAIL MOUNTING BASE No. 13-RC5160
(CODE No. 000-806-114, OPTION).
THE DIAMETER OF THE HANDRAIL SHOULD BE FROM
19mm TO 32mm.

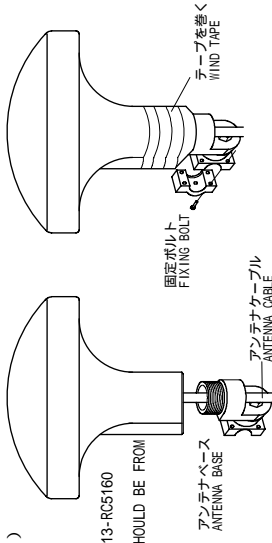

注記 1) パイプ(アンテナベース)はアンテナユニットにねじ込みだ後に固定する。
2) アンテナを固定するときパイプ(アンテナベース)をアンテナにねじ込むこと。
アンテナ側をねじるとコネクタ部やケーブルに無理がかかり、故障の原因となる。
NOTE 1. FASTEN PIPE (ANTENNA BASE) TO ANTENNA UNIT FIRST THEN FIX THEM TO MAST OR HANDRAIL.
2. WHEN FIXING PIPE OR ANTENNA BASE, NOT THE ANTENNA.
TURNING THE ANTENNA MAY TWIST THE CABLE AND PLACE STRESS ON CONNECTOR.

C) 取付ける場所が傾斜しているとき ANTENNA BASE MOUNTING

オプションのアンテナベースを使う。
USE OPTIONAL ANTENNA BASE No.13-0A330/0A310.

傾斜 INCLINATION	-5° - 33°	32° - 65°	65° - 98°
装備方法 MOUNTING METHOD			
アンテナベース型式 ANTENNA BASE TYPE	直型アンテナベース No.13-0A330	L型アンテナベース No.13-0A310	L型アンテナベース No.13-0A310
コード番号 CODE No.	000-803-239	000-803-240	000-803-240

アンテナベース基部 MOUNTING DIMENSIONS OF ANTENNA BASE



表 1 TABLE 1

寸法区分 (mm) DIMENSIONS	公差 (mm) TOLERANCE
0 < L 50	± 1.5
50 < L 100	± 2.5
100 < L 500	± 3

表 2 TABLE 2

型式 TYPE	質量 (kg) MASS (±10%)
NX-3H-D (NX-300)	0.94
NX-7H (NX-700)	0.6

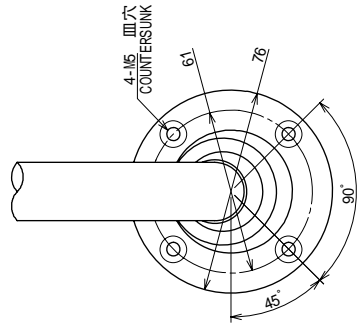
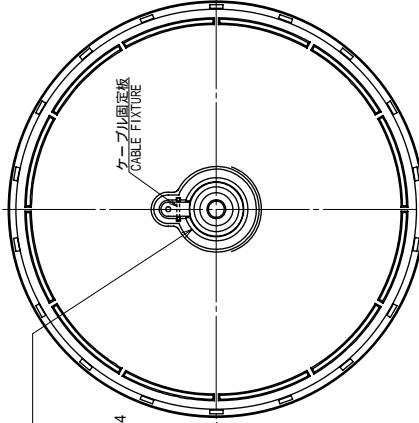
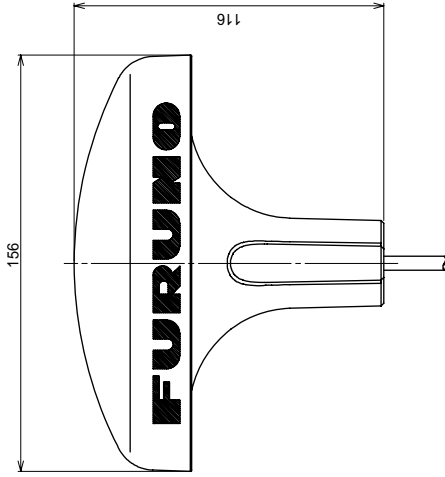

1-14UNS1B
ねじ山数 (25.4mmにつき) : 14
ねじピッチ : 1.8143 mm
オネジ有効長さ : 15.17 mm
オネジ有効径 : 24.17 mm
THREAD PER 25.4mm (1 INCH) : 14
PITCH: 1.8143 mm
THREAD LENGTH: 15.17 mm
PITCH DIAMETER: 24.17 mm

取付位置 MOUNTING LOCATION

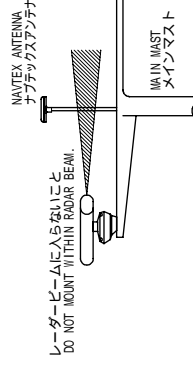

注記 1) 指定外の寸法公差は表 1 による。
NOTE 1. TABLE 1 INDICATES TOLERANCE OF DIMENSIONS WHICH IS NOT SPECIFIED.

DRAWN Oct. 13, '05	E. MIYOSHI
CHECKED	TAKAHASHI, T
APPROVED	Y. Hatai
SCALE 1/2	質量 質量 (10%ケーブルを含む) MASS 1/10M CABLE.
DWG. No.	C5629-G05-F 08-021-310G-1

TITLE	NX-3H-D/NX-7H
名称	空中線部/アンテナ部
外寸図	ANTENNA UNIT
OUTLINE DRAWING	OUTLINE DRAWING

空中線部
ANTENNA UNIT

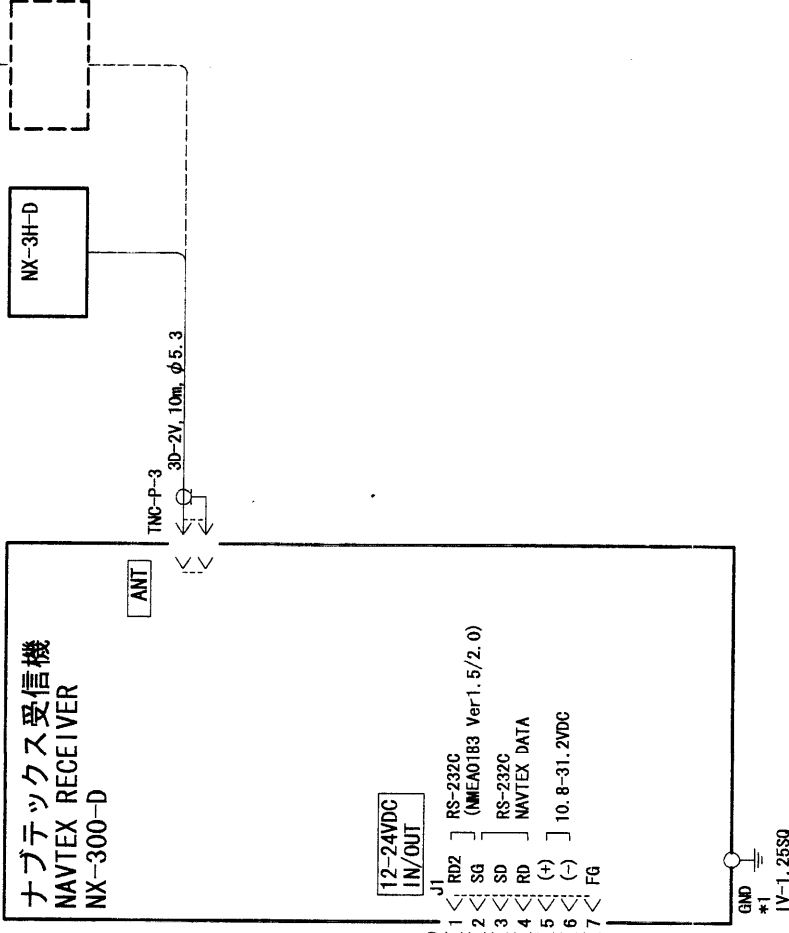

*3
航法装置など
NAVIGATION DEVICE, ETC.
GP-31/36

パーソナルコンピュータ
PERSONAL COMPUTER

電源
POWER SUPPLY
12-24 VDC

12-24VDC
IN/OUT
J1
RDZ
SG
SD
RD
(+)
(-)
FG
RS-232C
(NMEA0183 Ver1.5/2.0)
RS-232C
NAVTEX DATA
10.8-31.2VDC

MU-A7SPFD
*2
1 WHIT
2 RLU
3 YEL
4 ミドリ
5 アカ
6 クロ
7 BLK
FUSE 1A

GND
*1
1V-1.25SQ

注記

- *1) 現地手配。
- *2) コネクタは工場にて取付済み。
- *3) RC-232C以外のフォーマットの場合はレベル変換器が必要。

NOTE

- *1. LOCAL SUPPLY.
- *2. CONNECTOR FITTED AT FACTORY.
- *3. LEVEL CONVERTER REQUIRED FOR FORMAT OTHER THAN RS-232C.

DRAWN May. 9 '01 T. YAMASAKI	TITLE NX-300
CHECKED May 10 '01 Y. Kikuchi	名称 ナビテックス受信機
APPROVED May 10 '01 S. Yoshimura	相互結線図
SCALE MASS kg	NAME NAVTEX RECEIVER
DWG. No. C5629-C01-C	INTERCONNECTION DIAGRAM

A

All clear 4-1

AUTO 1-3

AUTO mode 2-3

AUTO-FAST 2-6

AUTO-SLOW 2-6

B

BATTERY icon 1-3, 5-2

C

Contrast 2-2

Control panel 2-1

D

Data sentence 6-4

Default setting 3-3

Deleting all messages 3-4

DEMO mode 4-1

Dimmer 2-2

E

ERROR RATE 2-5

F

FUNCTIONS menu 2-5

G

Grounding 6-4

I

Installation 6-1

K

KEY BEEP 2-5

L

Language menu 2-9

LCD check 5-2

Local time 3-2

M

Main menu 2-2

Maintenance 5-1

MANUAL mode 2-3

Message selection 2-4

Mounting 6-1

N

Navarea 1-1

Navigation data display 2-11, 3-4

NAVTEX area 1-1

NEW 1-3

O

Omnipad 2-1

P

Power on/off 2-1

Program version no. 5-2

R

RCV ALARM 2-5

RCV NOTIFY 2-5

Rx 1-3

S

SAR 1-3

Saving to PC 2-6

Scroll bar 1-3

SCROLLING 2-6

SKIP-\$\$ 2-6

Start code 1-2

Station list 1-5

Station map 1-4

Station selection 2-3

SYSTEM MENU 3-1

T

Termination code 1-2

TEST 5-1

TIME DIFF 3-2

Time difference 3-2

TIME DISP 3-3

Type of message 1-2

U

Units of measurement 3-1

User display 3-4

V

Version no. 2-1

VIEW mode 4-1

W

WARNING 1-3

Wiring 2-6, 6-3

FURUNO**FURUNO ELECTRIC CO., LTD.**

9-52 Ashihara-Cho, Nishinomiya City, 662-8580, Hyogo, Japan

Tel: +81 798-65-2111 Fax: +81 798-65-4200

Pub NO. DOC-390

Declaration of ConformityWe **FURUNO ELECTRIC CO., LTD.**-----
(Manufacturer)

9-52 Ashihara-Cho, Nishinomiya City, 662-8580, Hyogo, Japan

(Address)

declare under our sole responsibility that the product

NAVTEX receiver Model NX-300
(Serial No. 3519-0001 & 3519-0005)-----
(Model name, serial number)

is in conformity with the essential requirements as described in the Directive 1999/5/EC of the European Parliament and of the Council of 9 March 1999 on radio equipment and telecommunications terminal equipment (R&TTE Directive) and satisfies all the technical regulations applicable to the product within this Directive

EN 60945: 1997-01 (IEC 60945 Third edition: 1996-11)-----
(title and/or number and date of issue of the standard(s) or other normative document(s))

For assessment, see

- Statement of Opinion N° 01214017/AA/01 of 4 June 2001 issued by KTL Certification, The Netherlands
- EMS Test Report FLI 12-01-026 of 26 April 2001 prepared by Furuno Labotech International Co., Ltd.

On behalf of Furuno Electric Co., Ltd.

Hiroaki Komatsu
Manager,
International Rules and RegulationsNishinomiya City, Japan
June 11, 2001-----
(Place and date of issue)-----
(name and signature or equivalent marking of authorized person)