

# FURUNO

*Marine Display*  
15型カラーLCD表示器

# MU-150HD



**FURUNO ELECTRIC CO., LTD.**

[www.furuno.co.jp](http://www.furuno.co.jp)

OPERATOR'S MANUAL

取扱説明書

# IMPORTANT NOTICES

---

## General

- This manual has been authored with simplified grammar, to meet the needs of international users.
- The operator of this equipment must read and follow the descriptions in this manual. Wrong operation or maintenance can cancel the warranty or cause injury.
- Do not copy any part of this manual without written permission from FURUNO.
- If this manual is lost or worn, contact your dealer about replacement.
- The contents of this manual and equipment specifications can change without notice.
- The example screens (or illustrations) shown in this manual can be different from the screens you see on your display. The screens you see depend on your system configuration and equipment settings.
- Save this manual for future reference.
- Any modification of the equipment (including software) by persons not authorized by FURUNO will cancel the warranty.
- All brand and product names are trademarks, registered trademarks or service marks of their respective holders.

## How to discard this product

Discard this product according to local regulations for the disposal of industrial waste. For disposal in the USA, see the homepage of the Electronics Industries Alliance (<http://www.eiae.org/>) for the correct method of disposal.

## How to discard a used battery

Some FURUNO products have a battery(ies). To see if your product has a battery(ies), see the chapter on Maintenance. Follow the instructions below if a battery(ies) is used.

### In the European Union

The crossed-out trash can symbol indicates that all types of batteries must not be discarded in standard trash, or at a trash site. Take the used batteries to a battery collection site according to your national legislation and the Batteries Directive 2006/66/EU.

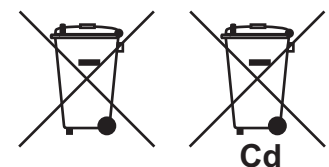

### In the USA

The Mobius loop symbol (three chasing arrows) indicates that Ni-Cd and lead-acid rechargeable batteries must be recycled. Take the used batteries to a battery collection site according to local laws.

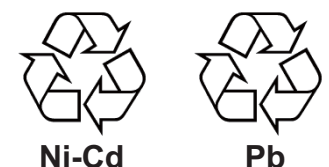

### In the other countries

There are no international standards for the battery recycle symbol. The number of symbols can increase when the other countries make their own recycle symbols in the future.



# SAFETY INSTRUCTIONS

Read these safety instructions before you operate the equipment.



## WARNING

Indicates a condition that can cause death or serious injury if not avoided.



## CAUTION

Indicates a condition that can cause minor or moderate injury if not avoided.



Warning, Caution



Prohibitive Action



Mandatory Action

### *Safety Instructions for the Operator*



## WARNING



**Immediately turn off the power at the switchboard if water leaks into the equipment or something is dropped into the equipment.**

Continued use of the equipment can cause fire or electrical shock. Contact a FURUNO agent for service.



**Immediately turn off the power at the switchboard if the equipment is emitting smoke or fire.**

Continued use of the equipment can cause fire or electrical shock. Contact a FURUNO agent for service.



**Do not disassemble or modify the equipment.**

Fire, electrical shock or serious injury can result.



**Turn off the power immediately if you feel the equipment is behaving abnormally.**

Turn off the power at the switchboard if the equipment becomes abnormally warm or is emitting odd noises. Contact a FURUNO dealer or agent for advice.



## WARNING



**Use the proper fuse.**

Fuse rating is shown on the power cable. Use of a wrong fuse can result in damage to the equipment.



**Do not place any object near the exhaust or intake vent.**

Fire may result.



## CAUTION



**Do not connect/disconnect the signal cable while turning the power on.**



The unit may be damaged.





**Handle the LCD monitor with care.**

The face of the LCD monitor is made of glass. Injury may result if the glass breaks.

***Safety Instructions for the Installer***

 <b>WARNING</b>	
	<p><b>Turn off the power at the switchboard before beginning the installation.</b></p> <p>Fire or electrical shock can result if the power is left on.</p>
	<p><b>Do not install the equipment where it may get wet from rain or water splash.</b></p> <p>Water in the equipment can result in fire, electrical shock or damage to the equipment.</p>

 <b>CAUTION</b>		
	<p><b>Observe the following compass safe distances to prevent interference to a magnetic compass:</b></p>	
	Standard compass	Steering compass
MU-150HD	0.65 m	0.45 m
	<p><b>When lifting the display unit, hold it together with the hard cover.</b></p> <p>Grasping by the hard cover alone may allow the display unit to fall, resulting in possible bodily injury or damage to the equipment.</p>	

**About the TFT LCD**

The TFT LCD is constructed using the latest LCD techniques, and displays 99.99% of its pixels. The remaining 0.01% of the pixels may drop out or blink, however this is not an indication of malfunction.

# TABLE OF CONTENTS

---

**Note:** This manual contains both English and Japanese instructions. The Installation Materials, Outline Drawings, and Interconnection Diagram are located at the back of this manual.

<b>FOREWORD</b> .....	<b>v</b>
<b>SYSTEM CONFIGURATION</b> .....	<b>vi</b>
<b>EQUIPMENT LISTS</b> .....	<b>vii</b>
<b>1. MOUNTING, WIRING</b> .....	<b>1</b>
1.1 Preparation .....	1
1.2 Flush Mounting, Fixed at Rear .....	3
1.3 Flush Mounting, Fixed at Front .....	6
1.4 Flush Mounting, Fixed at Rear, with hood .....	8
1.5 Desktop Mounting .....	10
1.6 Flush Mounting a Series Side by Side .....	13
1.7 Wiring .....	14
<b>2. ADJUSTMENTS</b> .....	<b>16</b>
2.1 RGB/DVI Setting .....	16
2.2 Video Composite Signal Setting .....	18
2.3 The Menu Window Setting .....	19
2.3.1 How to adjust the menu window .....	19
2.3.2 How to change the signal name .....	20
<b>3. OPERATION</b> .....	<b>21</b>
3.1 Controls .....	21
3.2 How to Turn the Power On/Off .....	22
3.2.1 Turn on/off the power .....	22
3.2.2 Lock the operation .....	22
3.3 How to Adjust the Display Brilliance .....	22
3.4 How to Select the Source for Main Picture .....	23
3.5 How to Select the Source for the PIP Window .....	23
3.6 SYSTEM Menu .....	24
3.6.1 How to set the auto dimmer .....	24
3.6.2 How to adjust the brilliance from the external equipment .....	25
3.6.3 How to clear the memory .....	25
<b>4. MAINTENANCE, TROUBLESHOOTING</b> .....	<b>26</b>
4.1 Maintenance .....	26
4.2 Troubleshooting .....	27
<b>SPECIFICATIONS</b> .....	<b>SP-1</b>
<b>INSTALLATION MATERIALS</b> .....	<b>A-1</b>
<b>OUTLINE DRAWINGS</b> .....	<b>D-1</b>
<b>INTERCONNECTION DIAGRAM</b> .....	<b>S-1</b>

# FOREWORD

---

## A Word to the Owner of the MU-150HD

FURUNO Electric Company thanks you for purchasing the MU-150HD 15" Marine Display. We are confident you will discover why the FURUNO name has become synonymous with quality and reliability.

For over 60 years FURUNO Electric Company has enjoyed an enviable reputation for quality and reliability throughout the world. This dedication to excellence is furthered by our extensive global network of agents and dealers.

Your equipment is designed and constructed to meet the rigorous demands of the marine environment. However, no machine can perform its intended function unless properly installed and maintained. Please carefully read and follow the operation, installation and maintenance procedures set forth in this manual.

We would appreciate feedback from you, the end-user, about whether we are achieving our purposes.

Thank you for considering and purchasing FURUNO.

## Features

The main features of the MU-150HD are as shown below.

- Selectable screen from RGB (1 line), Digital (2 lines) or Composite (3 lines).
- Main or remote display for radars, video sounders, sonars, plotter. For the connectable equipments, see "Connectable equipment" on page vi.
- High resolution display of 1024 x 768 (XGA)
- Brightness of 1000 cd/m<sup>2</sup> (maximum) and 0.3 cd/m<sup>2</sup> or less (minimum) for comfortable viewing day and night.
- Brilliance adjustment automatically with the light sensor.
- Picture-in-picture function
- Power on/off automatically through the DVI signal.

## Program Number

Program Name	Version	Date of Modification
Main	1.xx	Feb. 2010

xx: minor change

# SYSTEM CONFIGURATION

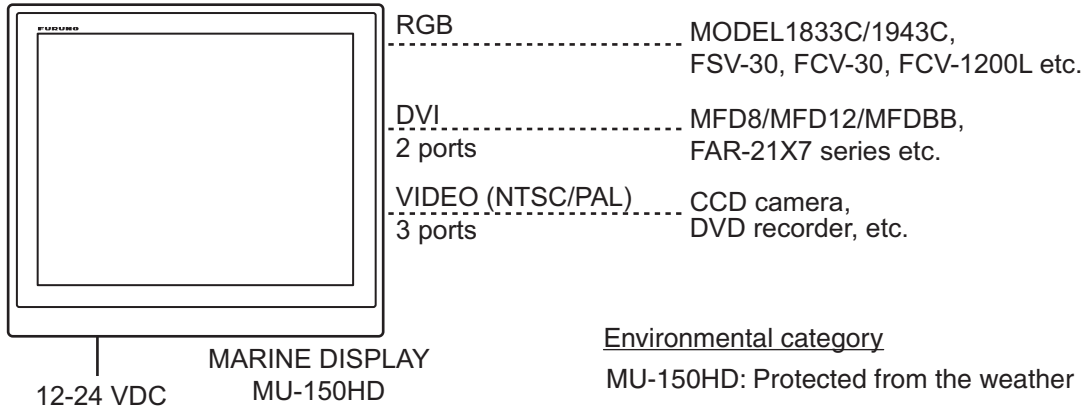

## Connectable equipment

Equipment	Resolution	Signal
FCV-1200L/M	VGA	Analog RGB, via IF-8000
CH-250/S	VGA	Analog RGB, via IF-8000
CH-270	VGA	Analog RGB, via IF-8000
CH-300	VGA	Analog RGB, via IF-8000
CSH-5L/8L	XGA	Analog RGB
FSV-24/S-BB	SXGA	Analog RGB
FSV-30/S-BB	SXGA	Analog RGB
FSV-84/L	SXGA	Analog RGB
FCV-30	SXGA	Analog RGB
CI-68/88	VGA	Analog RGB
FR-1510MK-3	XGA	Analog RGB, OP03-153 required
FR-21x5 series	SXGA	Analog RGB, OP03-162 required
FAR-21x7 series	SXGA	DVI
FEA-2107	SXGA	DVI
FEA-2807	SXGA	DVI
FCR-21x7 series	SXGA	DVI
FCR-28x7 series	SXGA	DVI
MODEL 1833C series (NAVnet)	VGA	Analog RGB, OP03-176 required
MODEL 1833C-BB series (NAVnet)	VGA	Analog RGB
MFD8 (NAVnet3D)	VGA	DVI
MFD12 (NAVnet3D)	SVGA	DVI
MFDDBB (NAVnet3D)	SVGA	DVI
	XGA	
	SXGA	

**Note 1:** This equipment is used as a display for a Non-SOLAS radar or ECDIS.

**Note 2:** Landscape orientation only.

**Note 3:** When inputting SXGA, a circle may be displayed as an ellipse because the aspect ratio differs. See "DISP MODE\*" on page 17. Also, it may be difficult to read small characters.

# EQUIPMENT LISTS

## Standard supply

Name	Type	Code No.	Qty	Remarks
Display Unit	MU-150HD	—	1	w/ Hard cover
Installation Materials	CP26-01300	000-016-267	1 set	<ul style="list-style-type: none"> <li>CP26-01302*</li> <li>Flush Mounting Plate Assy. (CP26-01301, Code: 001-080-760) 2 pcs.</li> <li>Cable Assembly (MJ-A3SPF0017-050ZC, Code: 000-157-995-10) 1 pc.</li> </ul>
Accessories	FP26-00401	001-080-780	1 set	LCD Cleaning Cloth (02-155-1082-1, Code: 100-332-651-10) 1 pc.
Spare Parts	SP26-00201	001-080-750	1 set	<ul style="list-style-type: none"> <li>Fuse (FGBO-A 125V 5A PBF, Code: 000-155-853-10) 3 pcs.</li> <li>Fuse (FGBO 125V 10A PBF, Code: 000-155-826-10) 3 pcs.</li> </ul>

\*: See the Installation materials at the back of this manual.

## Optional supply

Name	Type	Code No.	Qty	Remarks
Cable Assembly	3COX-2P-6C 5M	001-077-230-10	1	Cable length: 5 m (15 pin D-sub connector at both ends)
	3COX-2P-6C 10M	001-077-220-10	1	Cable length: 10 m (15 pin D-sub connector at both ends)
	DVI-D/D SINGLELINK5M	000-149-054-10	1	Cable length: 5 m (with DVI-D connector at both ends)
	DVI-D/D SINGLELINK10M	000-150-200-10	1	Cable length: 10 m (with DVI-D connector at both ends)
Bracket Assembly (w/knobs)	OP26-2	000-016-268	1 set	
Hood Assembly	OP26-3	001-080-840	1 set	
Flush Mount Kit	OP26-4	001-080-850	1 set	

# 1. MOUNTING, WIRING

---

## 1.1 Preparation

### Mounting type

You can install the display unit as follows. See the outline drawing at the back of this manual for mounting dimensions.

- Flush mounting, fixed at rear (standard)
- Flush mounting, fixed at front (option)
- Flush mounting, fixed at rear, with hood (option)
- Desktop mounting (option)
- Flush mounting a series side by side, fixed at rear

**Note:** The face of the LCD monitor is made of glass. Handle it with care.

### Mounting location

When you choose a mounting location, remember the following points:

- Make sure the mounting location is strong enough to support the weight of the unit.
- Locate the unit away from direct sunlight. An LCD may black out if it is exposed to direct sunlight for a long time.
- Select a location where the display can be easily viewed and the controls can be easily operated.
- Leave enough space around the unit for service and maintenance. See the outline drawing at the back of this manual for minimum service clearance.
- Locate the unit away from areas subject to water splash and rain.
- Observe the compass safe distances (see page iii) to prevent interference to a magnetic compass.

### How to remove/attach the hard cover

Before you install this display unit, remove the hard cover as follows.

 <b>CAUTION</b>
 <b>When lifting the display unit, hold it together with the hard cover.</b>
Grasping by the hard cover alone may allow the display unit to fall, resulting in possible bodily injury or damage to the equipment.

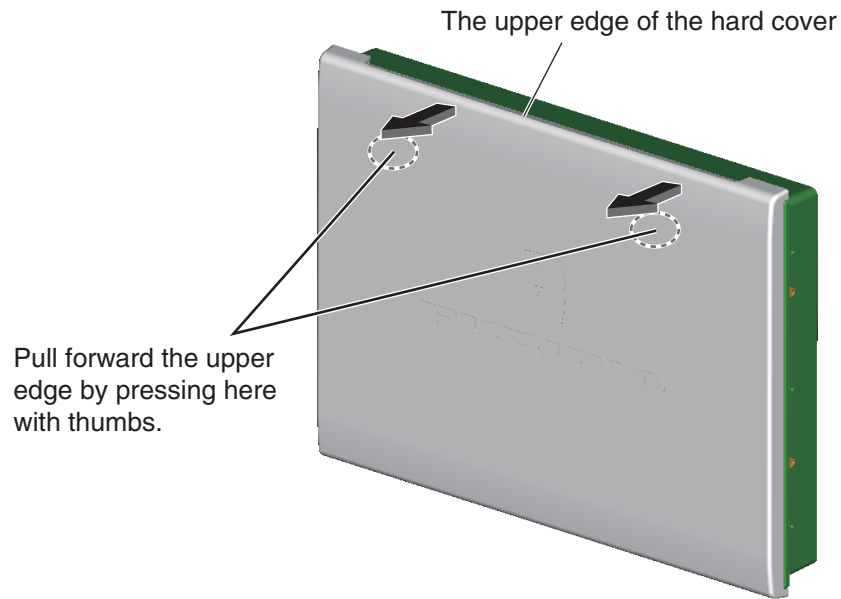

*How to remove the hard cover*

To attach the hard cover, follow the illustration in the figure below.

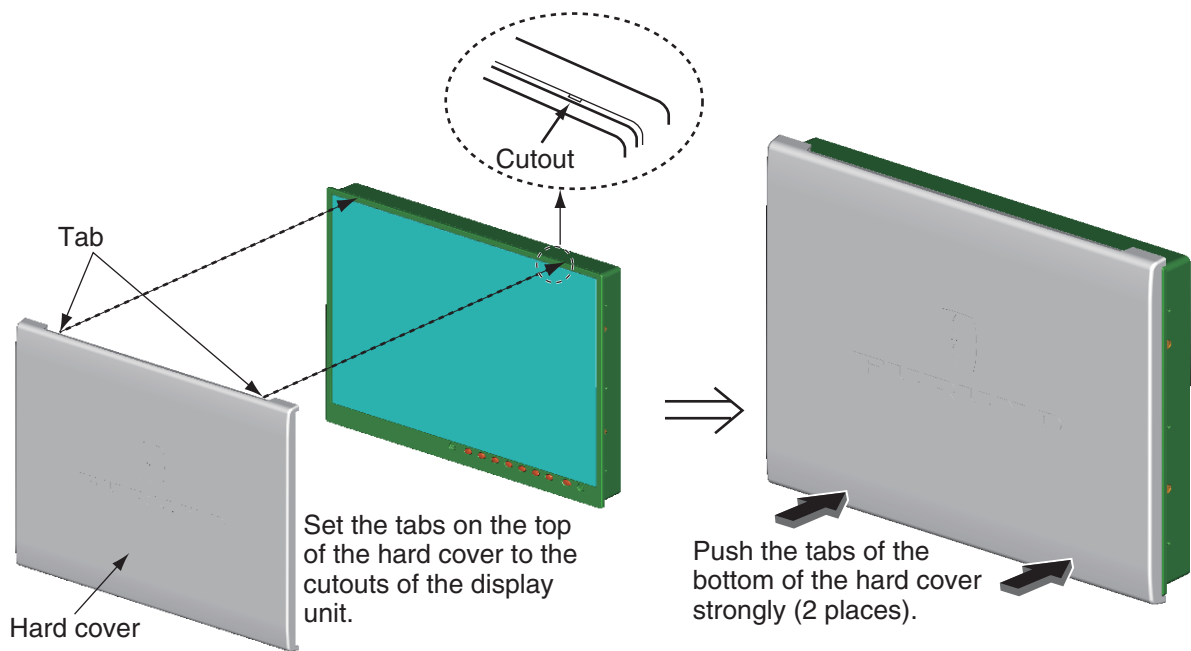

*How to attach the hard cover*

**Cable running**

Before you install the display unit, run all cables you use. See the interconnection diagram at the back of this manual.

# 1. MOUNTING, WIRING

## 1.2 Flush Mounting, Fixed at Rear

This is the standard installation method.

1. Make a cutout in the mounting location with the "Flush mounting template" (included).

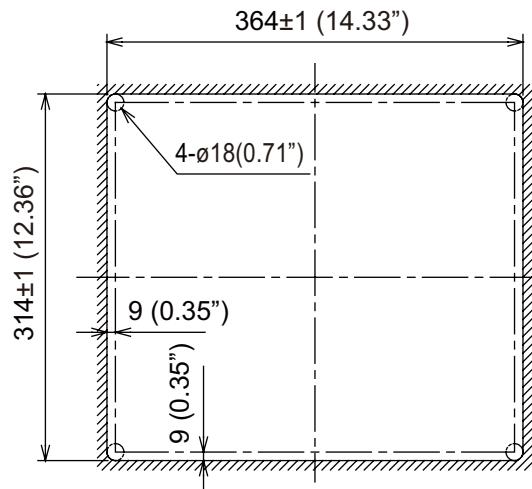

2. Attach the flush mounting sponges H15 and V15 in the order shown in the figure below.

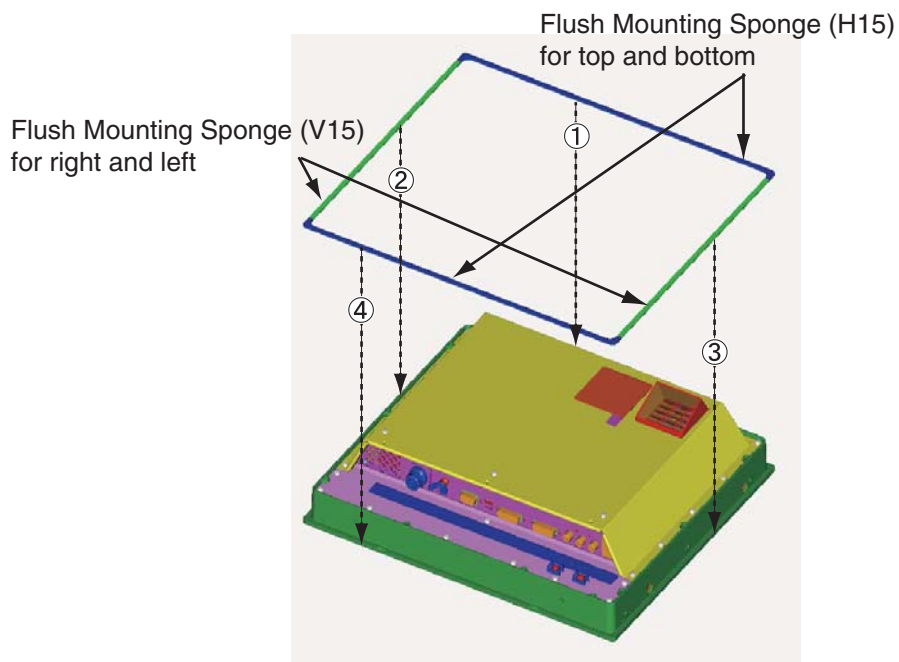

3. Connect all cables at the back of the display unit. See section 1.7.

4. Set the display unit to the cutout.

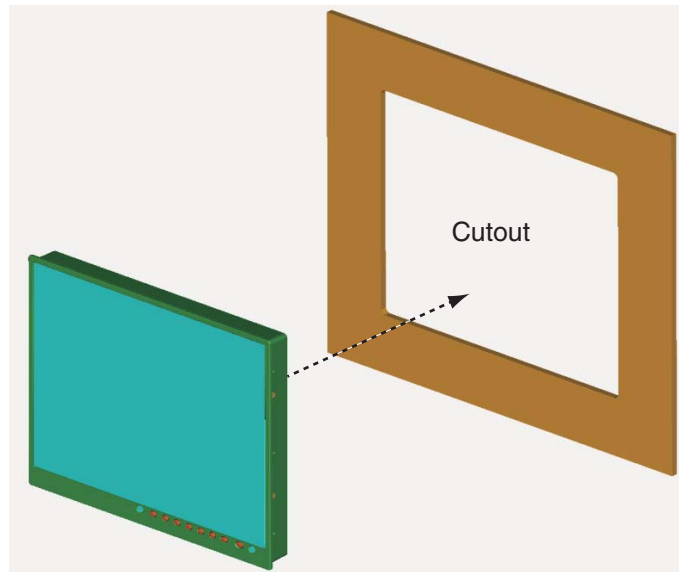

5. Screw the wing bolts and the wing nuts of the flush mount fixture so that the protector moves to the mounting plate.

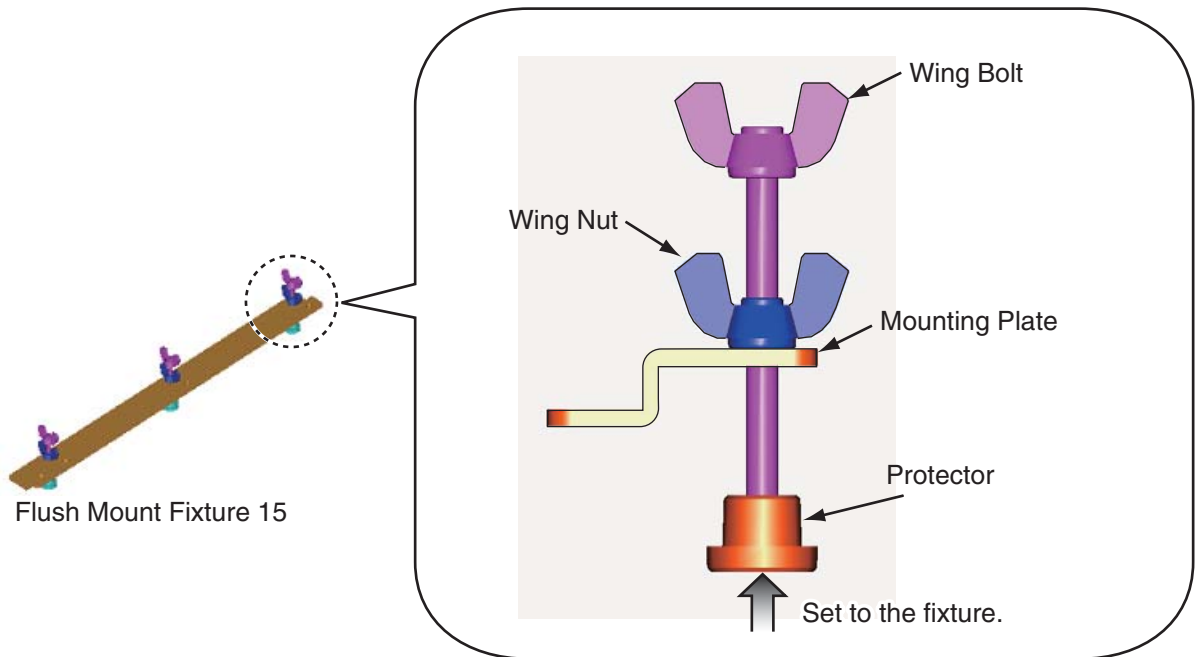

1. MOUNTING, WIRING

6. Fasten the flush mount fixture 15 to the right and left sides of the rear of the display unit with the washer head screws (6 places).

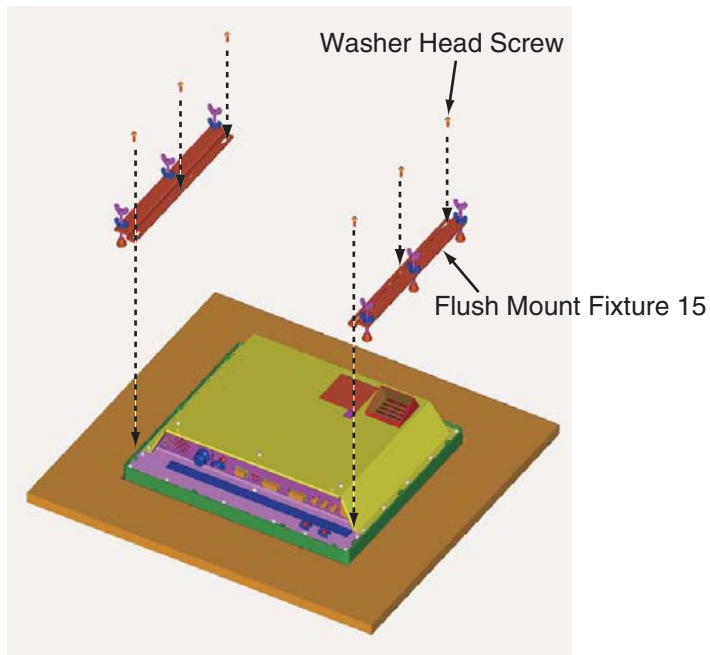

7. Fasten the wing bolts, in the order of the number shown in the figure below so that the protectors touch the mounting panel.

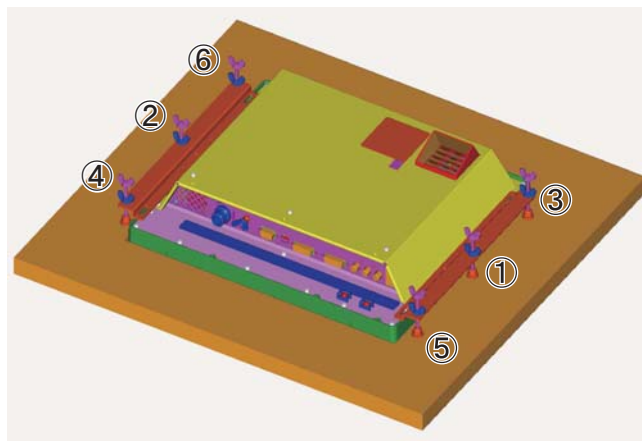

8. Fasten the wing bolts tightly, in the order shown in step 7.  
9. Fasten the wing nuts tightly.

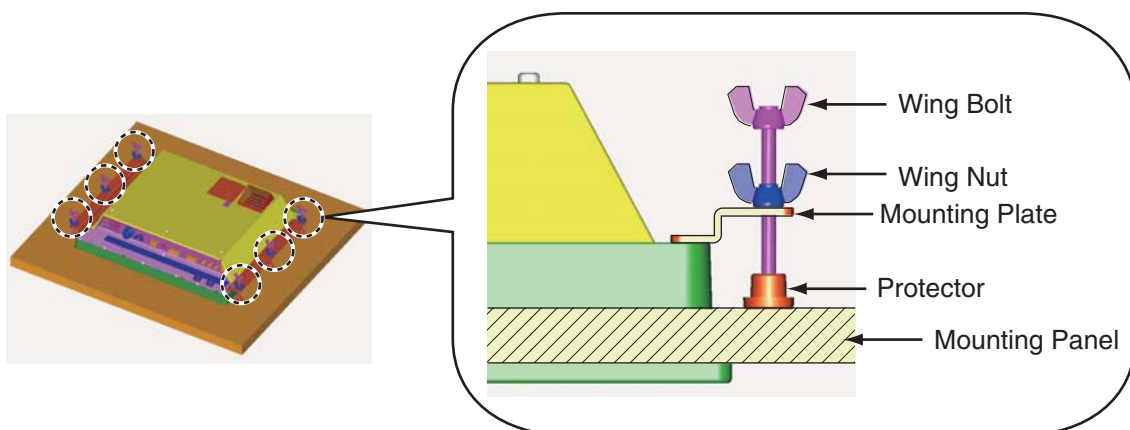

## 1.3 Flush Mounting, Fixed at Front

If you do not have the enough space to fix the display unit from the rear, you can fix it from the front with the Flush mount kit OP26-4 (option).

*Flush Mount Kit OP26-4 (Code: 001-080-850)*

Name	Type	Code No.	Qty.
Flush Mounting Panel (15)	OP26-4-1	001-080-960-00	1
Washer Head Screw	M4x10	000-163-836-10	8
Self Tapping Screw	5x20	000-162-609-10	4
Flush Mounting Template	C42-00909	000-172-636-10	1

1. Make a cutout in the mounting location with the flush mounting template (included).

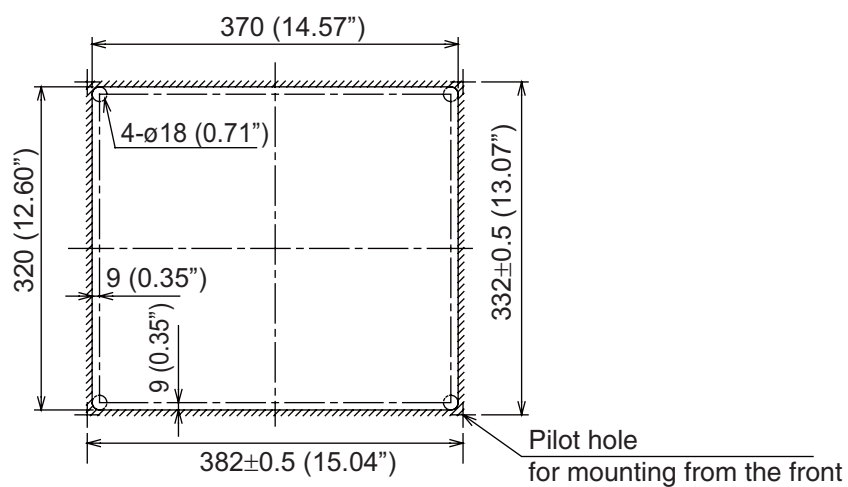

2. Attach the flush mounting sponges H15 and V15 in the order shown in the figure below.

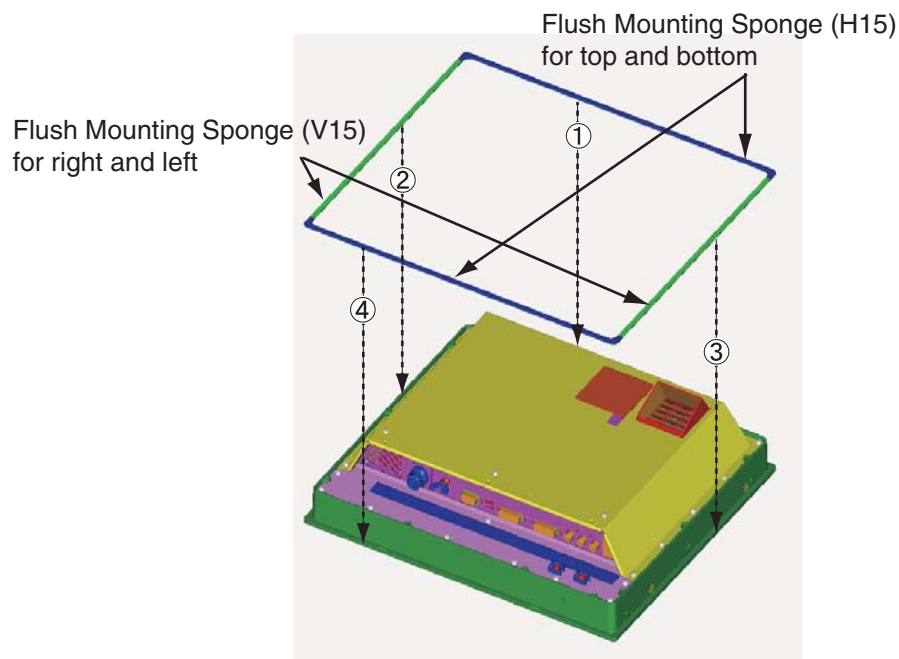

## 1. MOUNTING, WIRING

3. Attach the flush mounting panel to the display unit from the rear with the washer head screws (8 places). Do not confuse the top and bottom of the panel and check that screw holes on the panel and unit match.

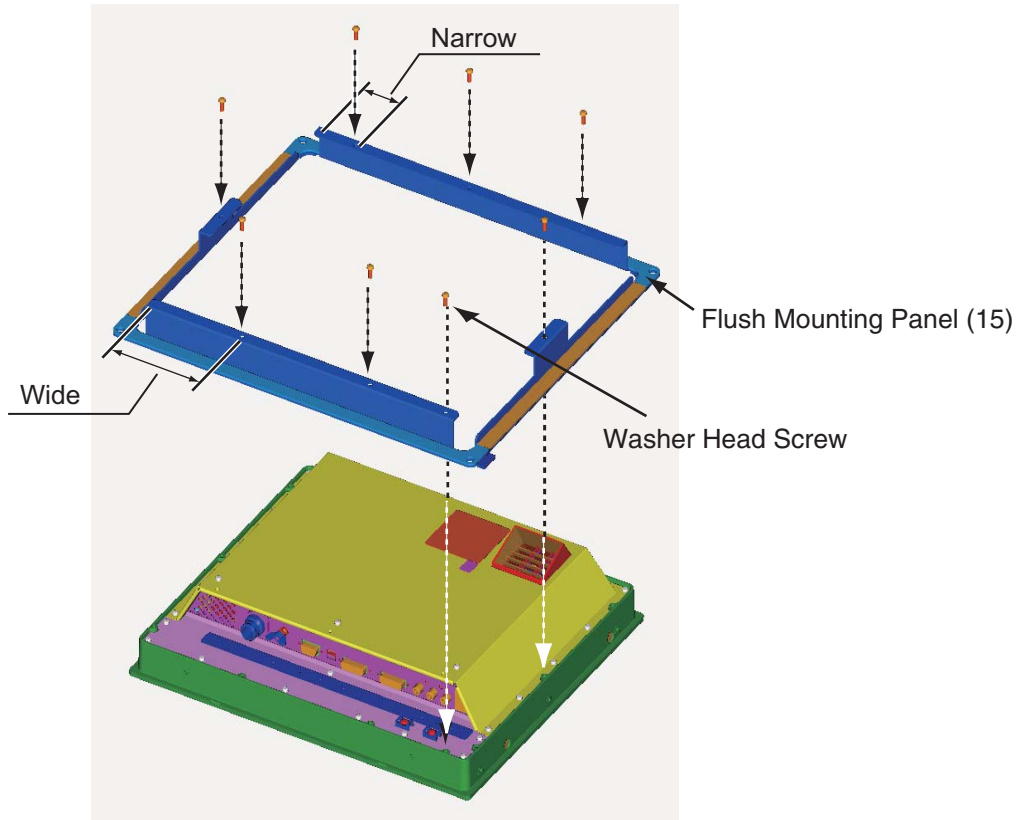

4. Connect all cables at the back of the display unit. See section 1.7.
5. Set the display unit assembly prepared at the step 3 to the cutout for the mounting location.
6. Fix the display unit to the cutout with the self tapping screws (4 places).

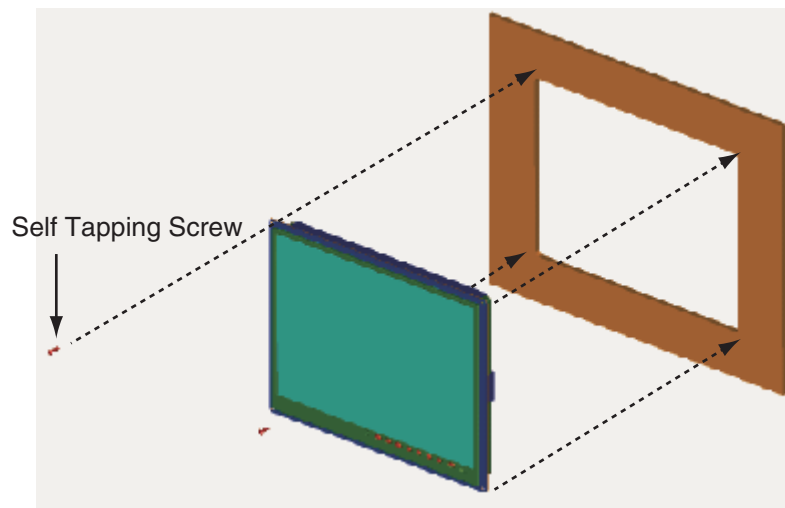

## 1.4 Flush Mounting, Fixed at Rear, with hood

You can attach a hood when flush mounting the unit from the rear, using the hood assembly OP26-3 (option).

### *Hood Assembly OP26-3 (Code: 001-080-840)*

Name	Type	Code No.	Qty.
Hood (15) Assembly	OP26-3-1	001-080-950-00	1
F-Mount Hood Gasket 15	26-005-2305	100-351-710-10	1
Hood Gasket Bottom 15	26-005-2306	1	
F-Mount Hood Gasket Side 15	26-005-2307	100-351-730-10	2
Hood Fixing Plate 15	26-005-2302	100-351-321-10	2
Knob M4	03-163-2303	100-343-602-10	4
Flat Head Screw	M3x8	000-172-167-10	6
Flush Mounting Template	C42-00908	000-172-635-10	1

1. Make a cutout in the mounting location with the flush mounting template (included).

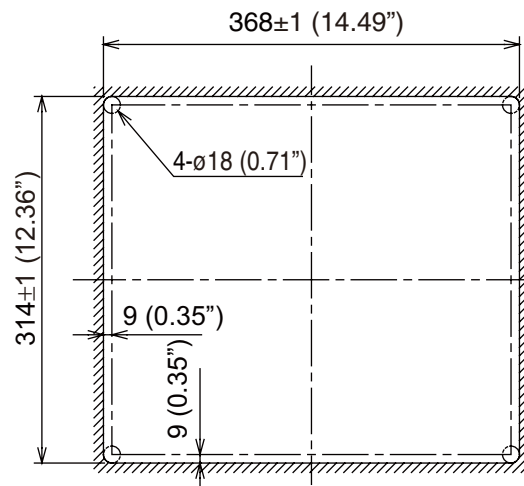

2. Fix the hood fixing plates to the right and left of the display unit with the flat head screws (6 places).

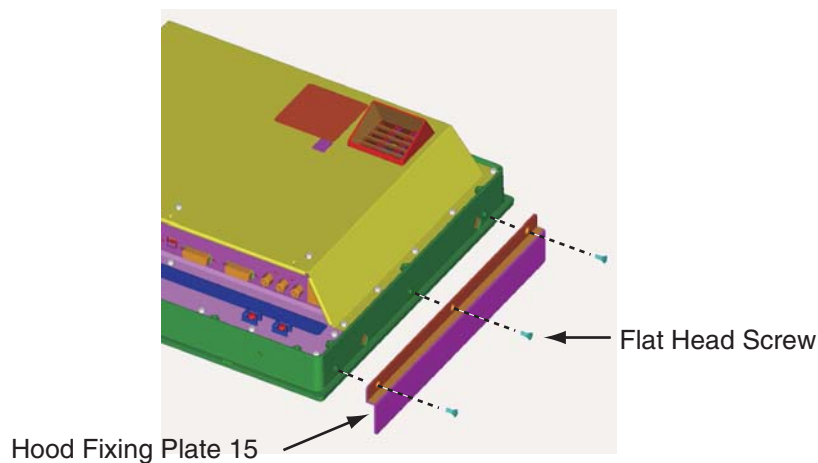

1. MOUNTING, WIRING

3. Attach the “F-Mount Hood Gasket 15” to the top brim, the “Hood Gasket Bottom 15” to the bottom brim, and then attach the “F-Mount Hood Gasket Side 15” to the right and left sides of the display unit from the rear side as shown the figure below.

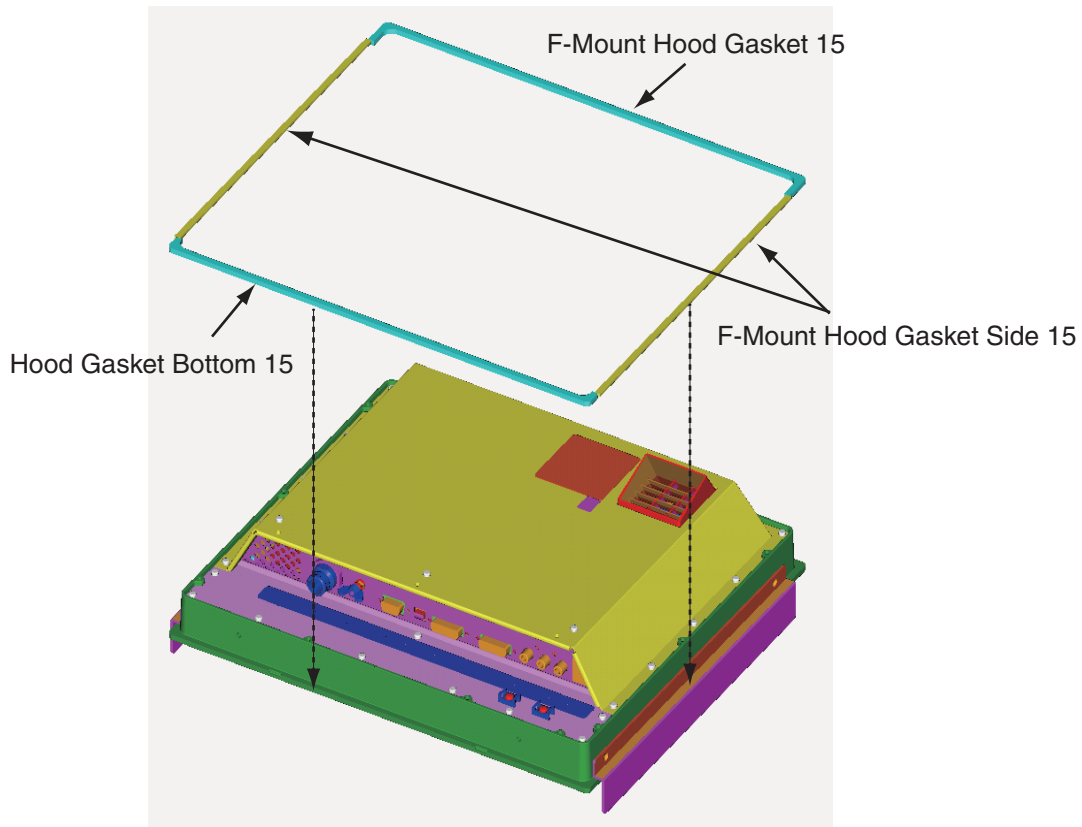

4. Follow steps 3 to 9 in section 1.2 to fix the display unit to the mounting location.  
5. Loosely fix the knobs (4 pcs.) to the hood fixing plate.  
6. Slide the cutouts of the hood assembly to the knobs.

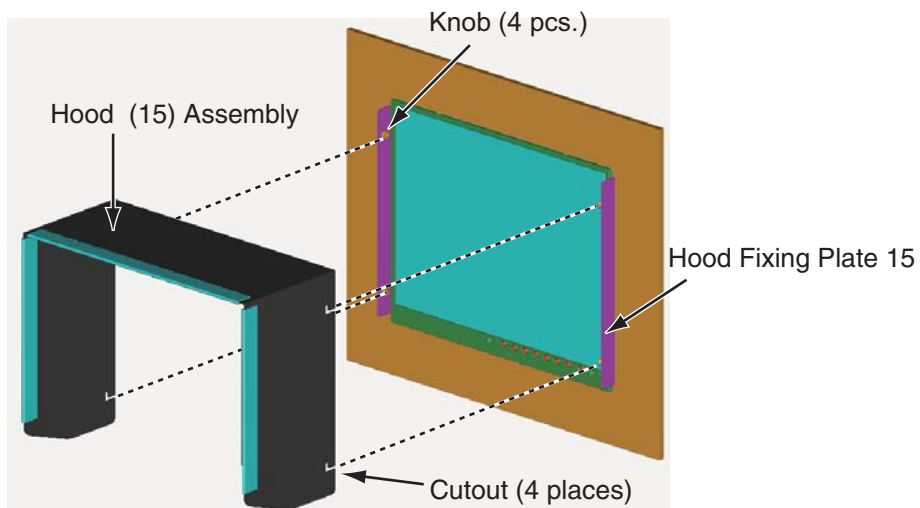

7. Press the top of the hood to fit the knobs in the cutouts.

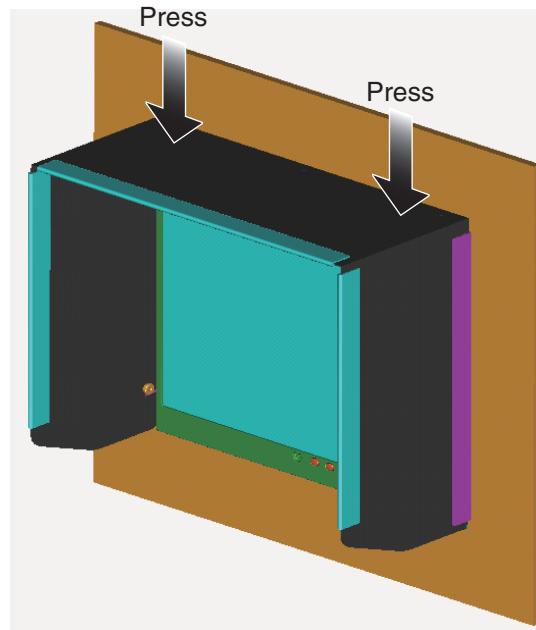

8. Fix the hood assembly with the knobs tightly (4 places).

## 1.5 Desktop Mounting

You can fix the display unit to a desktop, using the bracket assembly OP26-2 (option).

*Bracket assembly OP26-2 (Code: 000-016-268)*

Name	Type	Code No.	Qty.
Mounting Bracket (15)	OP26-2-1	001-080-820-00	1
Bracket Support w/knobs	OP26-2-2	001-080-830-00	
Self-Tapping Screw	5x20	000-162-608-10	4
Binding Head Screw	M4x10	000-172-165-10	9

## 1. MOUNTING, WIRING

1. Loosen the knobs of the bracket support to separate the mounting bracket from the bracket support.

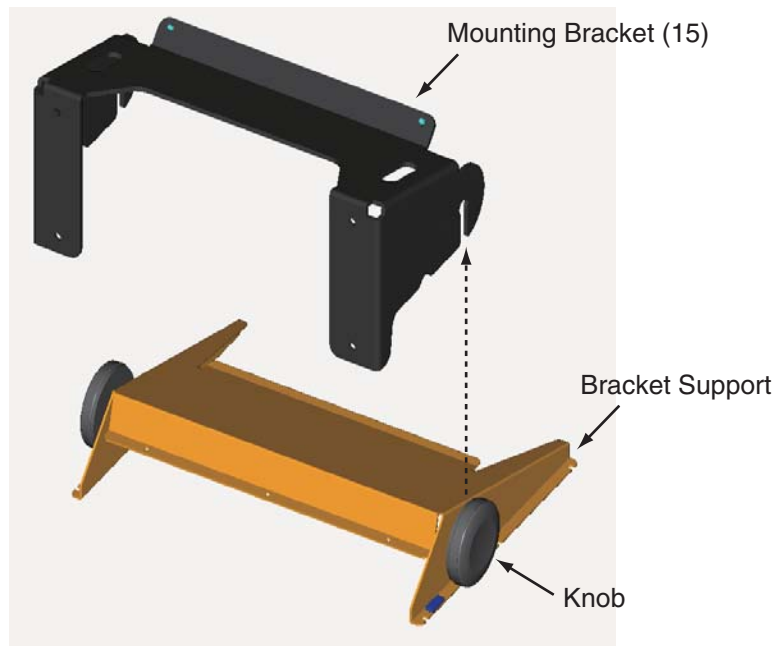

2. Set the mounting bracket to the mounting location with four self tapping screws.

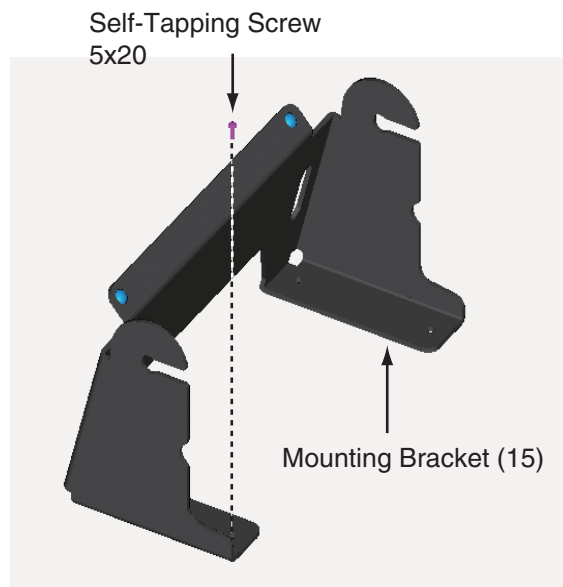

3. Attach the bracket support to the rear of the display unit with the binding head screws (9 places).

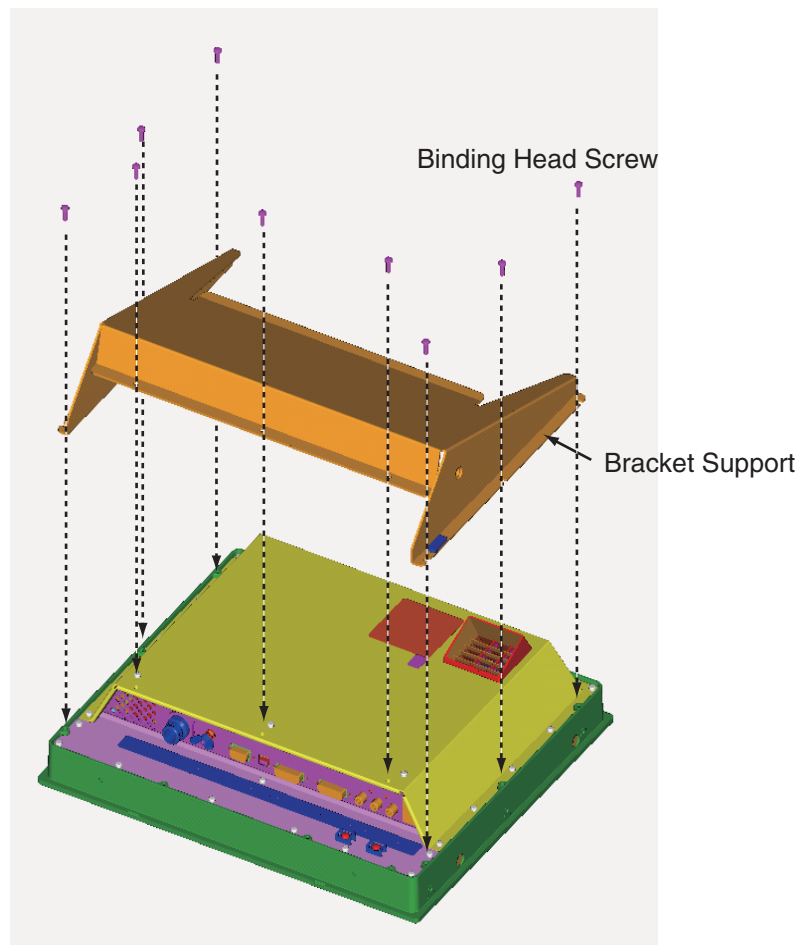

4. Connect all cables at the back of the display unit. See section 1.7.
5. Loosen the knobs of the bracket support and set them in the notches on the mounting bracket.

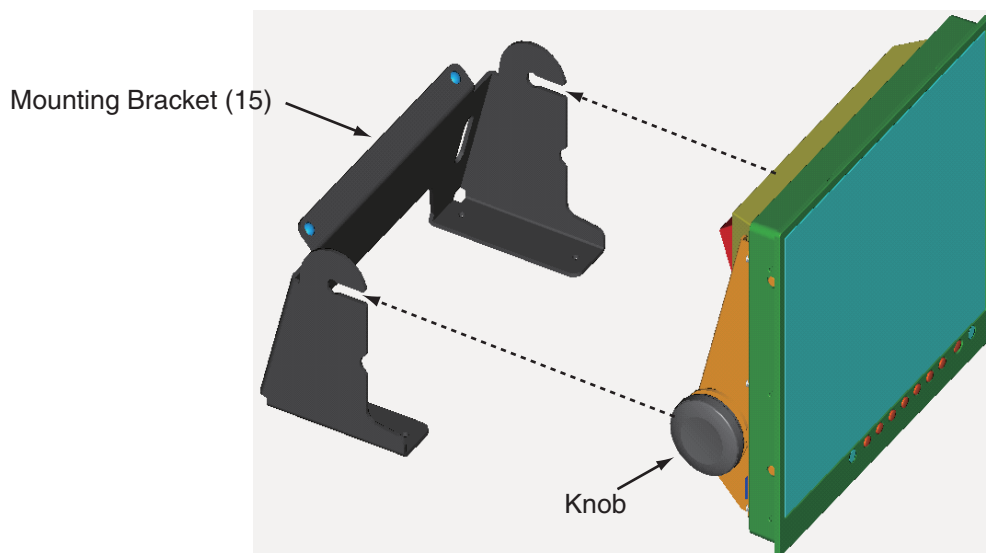

6. Adjust the angle of the display unit and fix the knobs tightly.

1. MOUNTING, WIRING

## 1.6 Flush Mounting a Series Side by Side

You can flush mount two display units side by side.

1. Make a cutout in the mounting location as shown below.

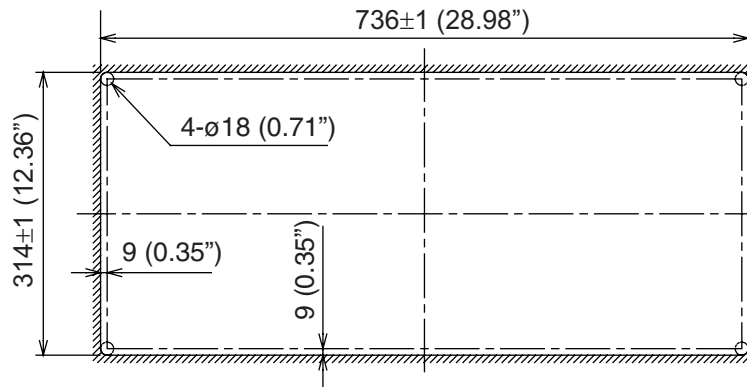

2. Follow steps 2 to 5 in section 1.2 to set the two display units in the mounting location.
3. Attach the flush mount fixtures with the washer head screws to join the two display units.

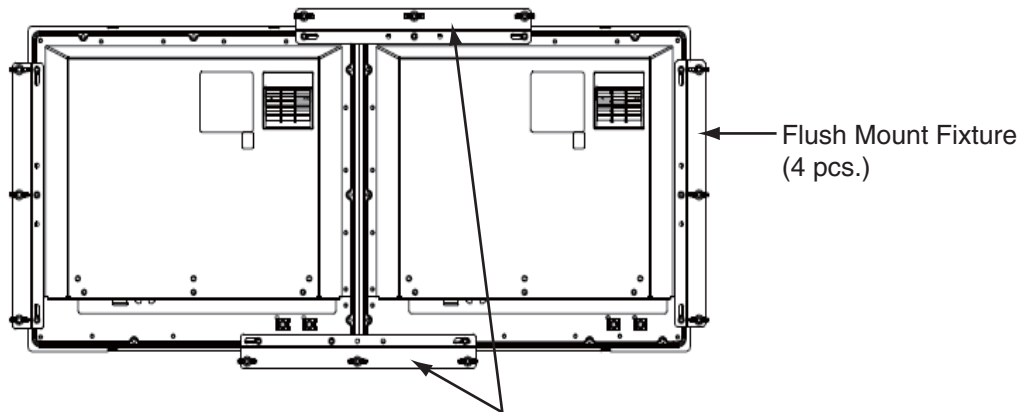

Join the display units with the flush mount fixtures.

4. Fasten the two display units tightly. See steps 7 to 9 in section 1.2.

## 1.7 Wiring

Refer to figure below and the interconnection diagram at the back of this manual to connect cables.

### Connector

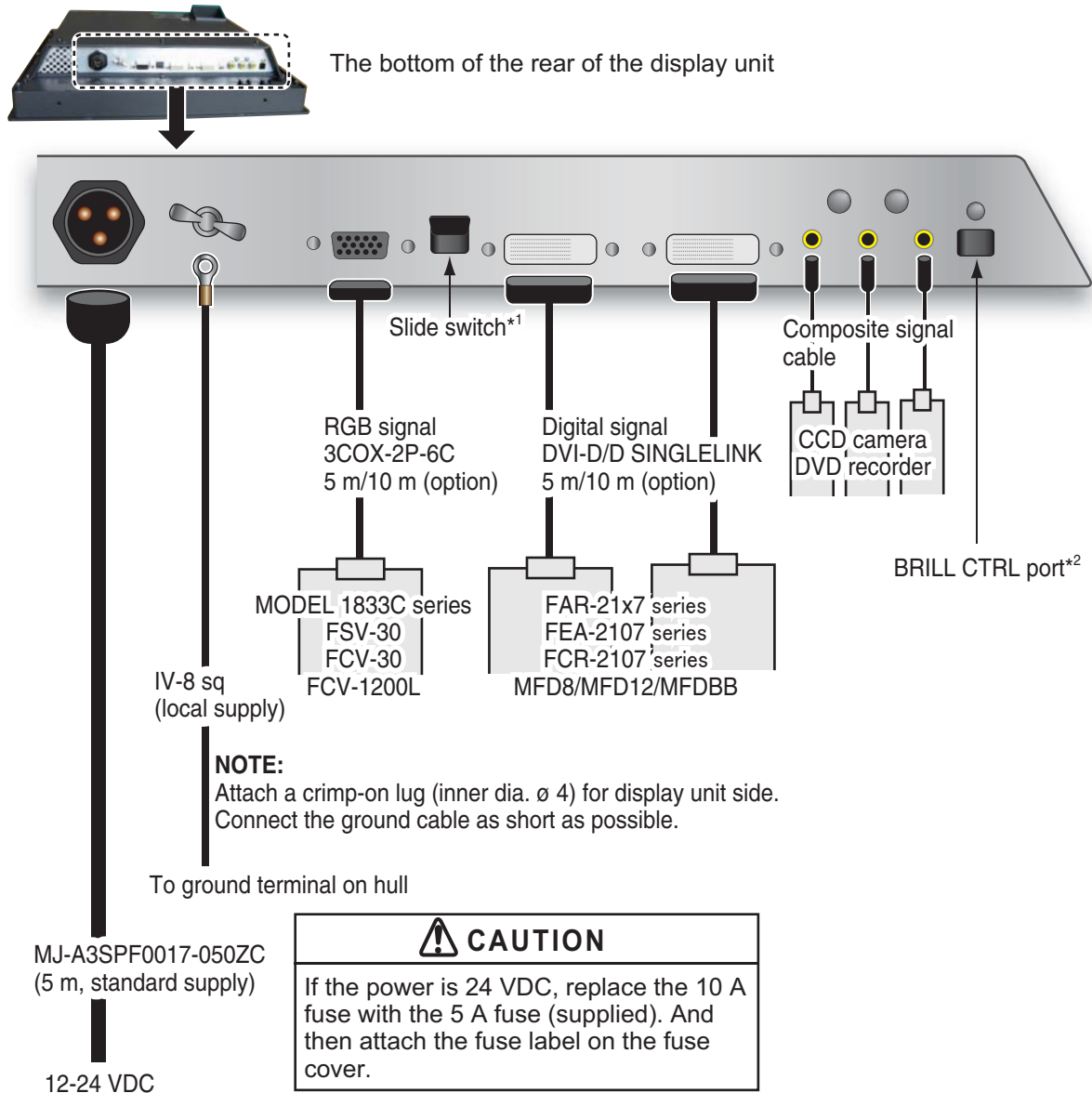

#### \*1: Slide switch

- ON (upward): Allow digital signal from external equipment to control on/off of the display unit.
- OFF (downward): Set this position for analog RGB signal.

**Note:** Turn the slide switch off when you connect equipments to both the DVI and RGB ports.

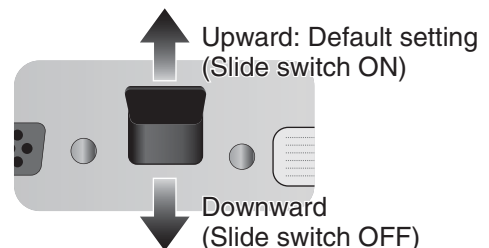

#### \*2: BRILL CTRL port

This is not available. Please do not remove the sticker on the connector.

## 1. MOUNTING, WIRING

### **How to fix composite signal cable**

Fix the cables for the composite signal at the fixing terminal with the cable tie to prevent a loose connection.

1. Pass the cable tie (supplied) through the side of the fixing terminal.
2. Set the cable in the cable tie and pull the tie.
3. Cut off the excess cable tie with nippers.

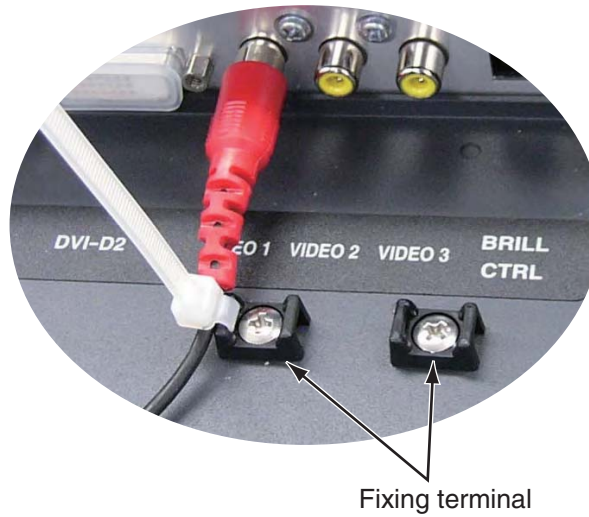

## 2. ADJUSTMENTS

Adjust the MU-150HD according to the equipment connected.

### 2.1 RGB/DVI Setting

You can adjust the screen from the [RGB], [DVI-D1] and [DVI-D2] ports separately. Turn on external equipment and adjust the display unit as follows.

1. Select the signal to adjust at the DISP selection window. See section 3.4.
  - 1) Press the **DISP** key.
  - 2) Press the **DISP** key again to select [RGB], [DVI1] or [DVI2].
2. Press the **MENU** key to show the menu.  
The main menu closes automatically when there is no operation for one minute.
3. Press the ◀ or ▶ key to select [RGB], [DVI1] or [DVI2].  
The current setting (the cursor) is shown in orange. The menu items depend on the selected menu. The same items are contained on [DVI1] and [DVI2] setting menus.

**Note:** The menus in grey are not available because of no signal.

RGB	DVI1	DVI2	VIDEO1	VIDEO2	VIDEO3	OSD	SYSTEM
H_SIZE				640			
V_SIZE				480			
PHASE				16	(1~32)		
CONTRAST				32	(1~64)		
H_POSITION				50	(1~99)		
V_POSITION				20	(1~40)		
R_LEVEL				31	(1~64)		
G_LEVEL				31	(1~64)		
B_LEVEL				31	(1~64)		
TEMPERATURE				7000K	(5500K/6500K/7000K/8000K)		
B_STRETCH				OFF	(OFF, 1~10)		
W_STRETCH				OFF	(OFF, 1~10)		
DISP MODE				FULL	(FULL/NORMAL)		
SHARPNESS				5	(1~10)		

RGB setting menu

RGB	DVI1	DVI2	VIDEO1	VIDEO2	VIDEO3	OSD	SYSTEM
CONTRAST				32	(1~64)		
H_POSITION				25	(1~50)		
V_POSITION				20	(1~40)		
R_LEVEL				31	(1~64)		
G_LEVEL				31	(1~64)		
B_LEVEL				31	(1~64)		
TEMPERATURE				7000K	(5500K/6500K/7000K/8000K)		
B_STRETCH				OFF	(OFF, 1~10)		
W_STRETCH				OFF	(OFF, 1~10)		
DISP MODE				FULL	(FULL/NORMAL)		
SHARPNESS				1	(1~10)		

DVI setting menu

4. Press the ▲ or ▼ key to select the menu item to adjust.

## 2. ADJUSTMENTS

5. Press the ◀ or ▶ key to adjust the setting.
6. Press the **MENU** key to close the menu.

### *RGB/DVI menu descriptions*

Menu item	Function	Setting
H_SIZE	Adjusts the image size horizontally. Horizontal size: ◀ (narrow), ▶ (wide)	Depending on input signal
V_SIZE	Adjusts the image size vertically. Vertical size: ◀ (narrow), ▶ (wide)	
PHASE**	Adjusts the sample timing so that the flicker disappears and the text is clear.	1 to 32
CONTRAST	Increases or decreases the contrast level. ◀ (darken), ▶ (brighten)	1 to 64
H_POSITION	Moves the image position horizontally. ◀ (leftward), ▶ (rightward)	1 to 99 (RGB), 1 to 50 (DVI1, DVI2)
V_POSITION	Moves the image position vertically. ◀ (upward), ▶ (downward)	1 to 40
R_LEVEL	Adjusts the red color level. ◀ (weaken), ▶ (strengthen)	1 to 64
G_LEVEL	Adjusts the green color level. ◀ (weaken), ▶ (strengthen)	1 to 64
B_LEVEL	Adjusts the blue color level. ◀ (weaken), ▶ (strengthen)	1 to 64
TEMPERATURE	Adjusts the color temperature. 5500K (the most reddish), 8000K (the most bluish)	5500K, 6500K, 7000K, 8000K
B STRETCH	Emphasizes the black color. [OFF] (standard), ◀ (weaken), ▶ (strengthen)	OFF, 1 to 10
W STRETCH	Emphasizes the white color. [OFF] (standard), ◀ (weaken), ▶ (strengthen)	OFF, 1 to 10
DISP MODE*	Selects the displaying method. [FULL]: Shows the input signal on entire screen. [NORMAL]: Shows the input signal with original aspect ratio.	FULL, NORMAL
SHARPNESS**	Sharpens the edge horizontally. ◀ (soften characters and lines), ▶ (sharpens characters and lines)	1 to 10

\*: When inputting SXGA, a circle may be displayed as an ellipse because the aspect ratio differs. In this case, select [NORMAL] from the [DISP MODE] menu item on the [RGB], [DVI1], or [DVI2] menus. The right and left on the screen are left blank, but this is normal.

\*\* : If the characters are not clear, adjust [PHASE] and [SHARPNESS].

## 2.2 Video Composite Signal Setting

You can adjust the VIDEO1, 2 or 3 signal from the VIDEO1, VIDEO2 and VIDEO3 ports separately. The VIDEO1, 2 or 3 signal is displayed in the PIP window also.

1. Select the signal to adjust at the DISP selection window.
2. Press the **MENU** key to show the menu.
3. Press the ◀ or ▶ key to select [VIDEO1], [VIDEO2] or [VIDEO3].  
The same items are contained on [VIDEO1], [VIDEO2] and [VIDEO3] setting menus.

RGB	DVII	DVI2	VIDEO1	VIDEO2	VIDEO3	OSD	SYSTEM
PIP_SIZE			5	(1~10)			
CONTRAST			32	(1~64)			
R_LEVEL			31	(1~64)			
G_LEVEL			31	(1~64)			
B_LEVEL			31	(1~64)			
TEMPERATURE		7000K		(5500K/6500K/7000K/8000K)			
B STRETCH			OFF	(OFF, 1~10)			
W STRETCH			OFF	(OFF, 1~10)			

*[VIDEO1] (2 or 3) setting menu*

4. Press the ▲ or ▼ key to select the menu item to set.
5. Press the ◀ or ▶ key to adjust the setting.
6. Press the **MENU** key to close the menu.

### VIDEO menu descriptions

Menu item	Function	Setting
PIP_SIZE	Adjusts the size of picture-in-picture window. <b>Note:</b> This setting is available when the PIP window is displayed.	1 (47 mm x 31 mm) to 10 (235 mm x 160 mm)
CONTRAST	Increases or decreases the contrast level.	1 to 64
R_LEVEL	Adjusts the red color level.	1 to 64
G_LEVEL	Adjusts the green color level.	1 to 64
B_LEVEL	Adjusts the blue color level.	1 to 64
TEMPERATURE	Adjusts the color temperature.	5500K, 6500K, 7000K, 8000K
B STRETCH	Emphasizes the black color.	OFF, 1 to 10
W STRETCH	Emphasizes the white color.	OFF, 1 to 10

(Refer to "RGB/DVI menu descriptions" on page 17.)

## 2.3 The Menu Window Setting

### 2.3.1 How to adjust the menu window

You can adjust the position and transparency of the menu window on the [OSD] (On Screen Display) menu.

1. Press the **MENU** key to show the menu.
2. Press the ◀ or ▶ key to select [OSD].

RGB	DVI1	DVI2	VIDEO1	VIDEO2	VIDEO3	OSD	SYSTEM
H_POSITION			11	(1~22)			
V_POSITION			21	(1~23)			
TRANSLUCENT			OFF	(OFF/ON)			
PIP SW TIME			OFF	(OFF, 5~20)			
PIP SKIP			OFF	(OFF, V1/V2/V3)			
CUSTOM NAME							
RGB	=	RGB	_____				
DVI1	=	DVI1	_____				
DVI2	=	DVI2	_____				
VIDEO1	=	VIDEO1	_____				
VIDEO2	=	VIDEO2	_____				
VIDEO3	=	VIDEO3	_____				

*OSD menu*

3. Press the ▲ or ▼ key to select the menu item to set.
4. Press the ◀ or ▶ key to adjust the setting.
5. Press the **MENU** key to close the menu.

OSD menu description

Menu item	Function	Setting
H_POSITION	Moves the menu window horizontally. ◀ (leftward), ▶ (rightward)	1 to 22
V_POSITION	Moves the menu window vertically. ◀ (upward), ▶ (downward)	1 to 23
TRANSLUCENT	Adjusts the transparency of the background color on the menu window. [OFF]: Blue, [ON]: Translucent <b>Note: Alpha blending technology is used for transparency effects.</b>	OFF, ON
PIP SW TIME	Switches the screen image on the PIP window among VIDEO1, VIDEO2 and VIDEO3 at the interval (5 to 20 seconds) selected here. When [OFF] is selected, this function is not available.	OFF, 5 to 20
PIP SKIP	Selects which video signals to skip in the PIP window when PIP SW TIME is active. OFF: VIDEO1, VIDEO2 and VIDEO3 are shown in turn. V1: VIDEO1 is skipped. VIDEO2 and VIDEO3 are shown alternately. V2: VIDEO2 is skipped. VIDEO1 and VIDEO3 are shown alternately. V3: VIDEO3 is skipped. VIDEO1 and VIDEO2 are shown alternately.	OFF, V1, V2, V3
CUSTOM NAME	See paragraph 2.3.2.	

### 2.3.2 How to change the signal name

You can change the signal name (“RGB”, “DVI1” or “VIDEO1” etc.) to a name (ex. the equipment name) which is easy to understand. The changed name is shown in the DISP selection window, PIP selection window and the indication shown at the upper right of the screen. See section 3.4 and section 3.5

1. Press the **MENU** key to show the main menu.
2. Press the ◀ or ▶ key to select [OSD].

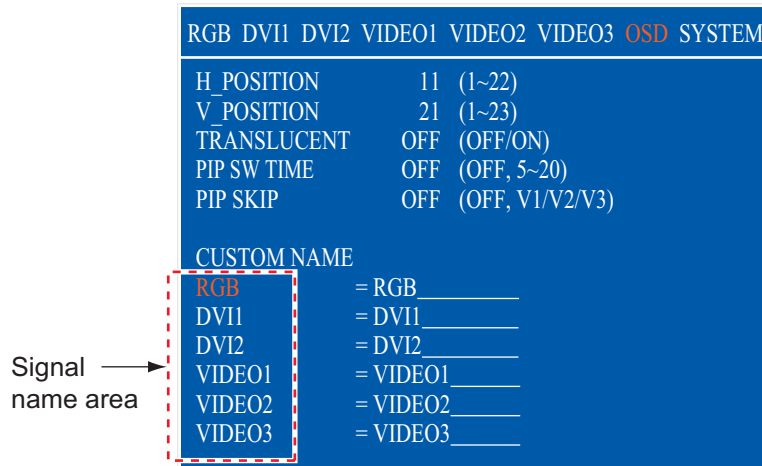

*Signal name area*

3. Press the ▲ or ▼ key to select the signal to change its name in the signal name area. In the example above, RGB is selected.
4. Press the ▶ key to select the character to change. In the example below, “G” of RGB is selected.

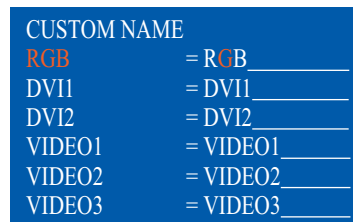

5. Press the ▲ or ▼ key to select appropriate alphanumeric character. In the example below, “5” is selected.

You can set up to ten characters. “A to Z”, “0 to 9”, “-”, “.”, “ ” (space) are available.

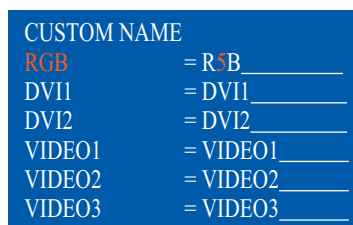

6. To change another signal name, press the ◀ key several times to return the cursor to the signal name area. Repeat steps 3 to 5.
7. Press the **MENU** key to close the menu.

# 3. OPERATION

## 3.1 Controls

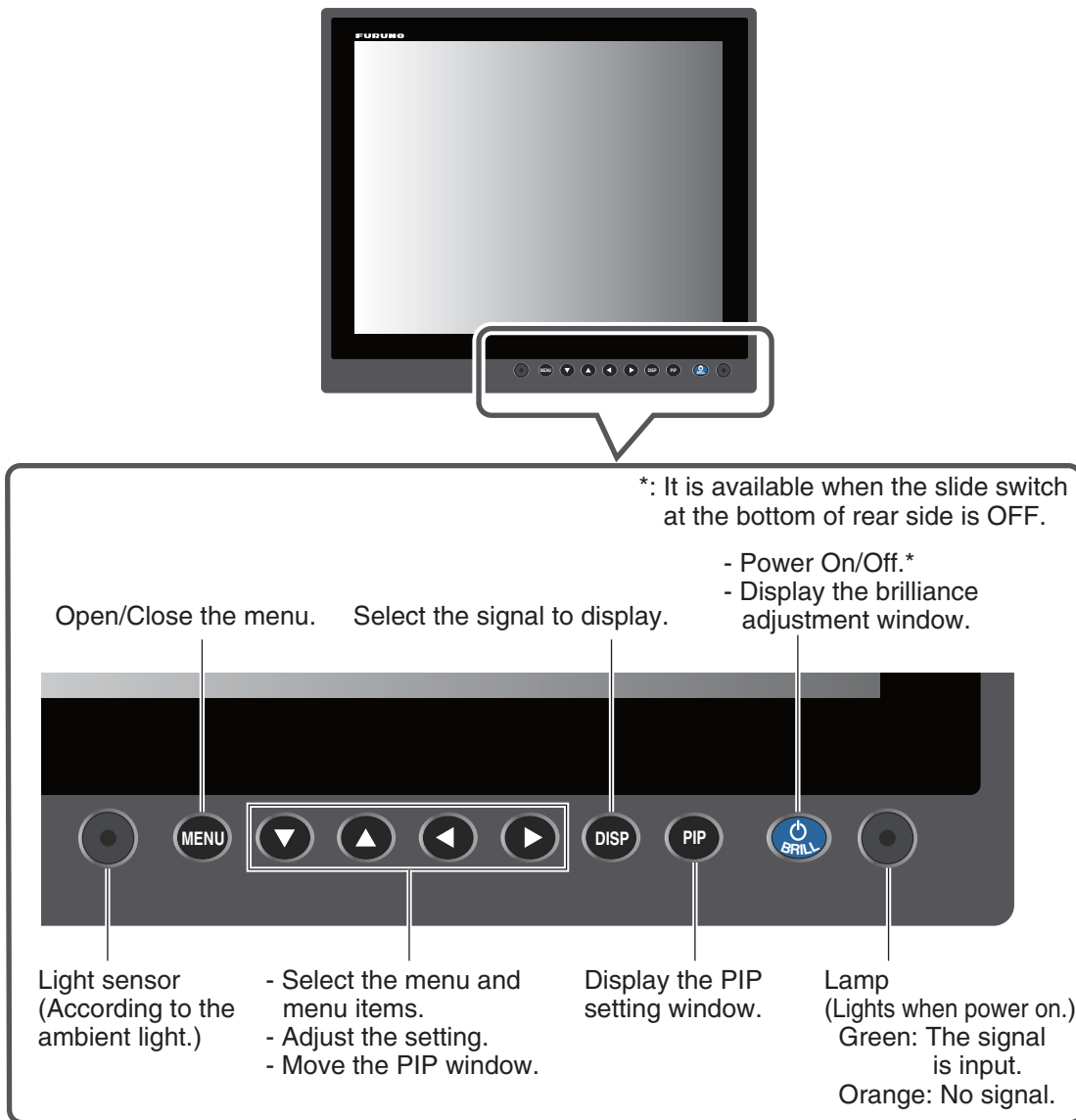

## 3.2 How to Turn the Power On/Off

This section shows how to turn on/off the display unit and the key lock function.

### 3.2.1 Turn on/off the power

How to turn on/off the power depends on the setting of the slide switch. The slide switch is set when the display unit is installed. See section 1.7.

**Note:** When you restart the display unit, wait at least three seconds before powering the unit.



#### Slide switch “ON”

The external equipment connected to the DVI port (DVI-D1 or DVI-D2) can power on/off the display unit.

**Note 1:** You can not turn on the power with the /BRILL key on MU-150HD.

**Note 2:** When you connect the cables to both DVI-D1 and DVI-D2 ports, turn off the power of the connected equipments to turn off the display unit.

#### Slide switch “OFF”

1. Press the /BRILL key to turn on the display unit.
2. Press and hold the /BRILL key for three seconds to turn off the display unit. While you hold the key, the display shown right appears.



SHUT DOWN  
This monitor will shut down in three seconds.

### 3.2.2 Lock the operation

You can lock the display unit to prevent operation. Any key (except the /BRILL key) will be inoperative.

1. While you hold the **PIP** key, turn on the display unit. Press and hold the **PIP** key for more than five seconds.  
**Note:** When the slide switch is “ON”, turn on the connected external equipment while pressing the **PIP** key to turn on the display unit.
2. To cancel the lock, turn off the display unit and then turn it on while you hold the **PIP** key. Press and hold the **PIP** key more than five seconds.

## 3.3 How to Adjust the Display Brilliance

You can adjust the display brilliance as follows:

**Note:** The auto dimmer must be off to use this feature. See paragraph 3.6.1.

1. Press the /BRILL key momentarily to show the BRILL adjustment window.

The window shown right disappears if there is no operation for five seconds.

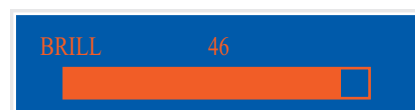

### 3. OPERATION

2. Press the ◀ or ▶ key to adjust the brilliance (available range: 1 to 50).  
You can also adjust the brilliance by pressing the ⏻/BRILL key repeatedly.
3. Press the ▲ or ▼ key to close the window.

**Note 1:** If you turn off the display unit with the minimum brilliance, you may become difficult to watch the screen because of the ambient light at the next start. In this case, press the ⏻/BRILL key repeatedly.

**Note 2:** When you use the display unit for FAR-21x7 series, you can adjust the brilliance from the FAR-21x7 series. (see paragraph 3.6.2.)

## 3.4 How to Select the Source for Main Picture

Select the signal to display on the entire screen as follows:

1. Press the **DISP** key to show the DISP selection window.  
The signal names are shown as you customized at paragraph 2.3.2 on the window. This window disappears if there is no operation for five seconds.

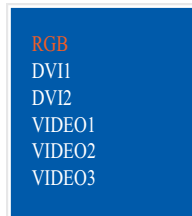

*DISP selection window (Default setting)*

2. Press the ▲ or ▼ key to select a signal.  
You can also select the signal by pressing the **DISP** key continuously.  
[RGB]: The signal from the RGB port is displayed.  
[DVI1], [DVI2]: The signal from the selected DVI port is displayed.  
[VIDEO1] - [VIDEO3]: The external video from the selected VIDEO port is displayed.
3. Press the ◀ or ▶ key to close the window.  
The name of the selected signal appears at the right top corner for five seconds after the DISP selection window disappears. If there is no signal, "NO SIGNAL" appears.

## 3.5 How to Select the Source for the PIP Window

Select the source for the PIP (picture-in-picture) window as follows. The PIP window is available on the RGB, DVI1 or DVI2 display.

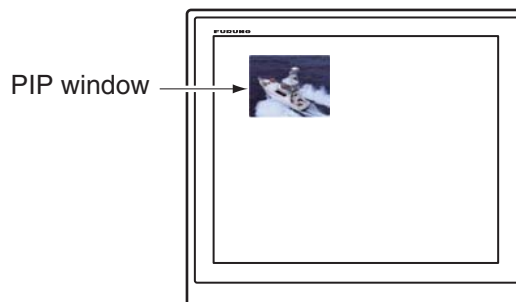

- When the RGB, DVI1 or DVI2 display appears, press the **PIP** key.  
The PIP selection window appears. The signal names are shown as you customized at paragraph 2.3.2 on the window. This window disappears if there is no operation for five seconds.

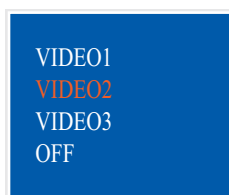

*PIP selection window (Default setting)*

- Press the ▲ or ▼ key to select the VIDEO port required.  
[VIDEO1] (2 or 3) can also be selected by pressing the **PIP** key continuously. When you select the [VIDEO1], [VIDEO2] or [VIDEO3], the PIP window is displayed. To close the PIP window, select [OFF].
- Press the ◀ or ▶ key to close the PIP setting window.
- You can move the PIP window by pressing the arrow keys when the menu is closed.

**Note 1:** To show the VIDEO1, VIDEO2 and VIDEO3 pictures alternately, set the cycle time (5 -20 sec) with [PIP SW TIME] on the [OSD] menu. In this case, the above setting is invalid. See paragraph 2.3.1.

**Note 2:** You can adjust the size of the PIP window on the [VIDEO1] (2 or 3) menus. See section 2.2.

## 3.6 SYSTEM Menu

You can set the brilliance control and clear the memory on the [SYSTEM] menu. Also, you can check the signal status and the program number on the [SYSTEM] menu.

### 3.6.1 How to set the auto dimmer

The auto dimmer feature automatically adjusts the brilliance according to lighting conditions detected by the light sensor on the front panel. Also, you can select the interval in which the brilliance is adjusted.

**Note:** Do not put any objects in front of the light sensor.

- Press the **MENU** key to show the main menu.
- Press the ▶ key to select [SYSTEM].

The message "Input Signal Searching. Please Wait." is displayed and then the [SYSTEM] menu shown right is displayed.

Signal status  
and Program  
number →

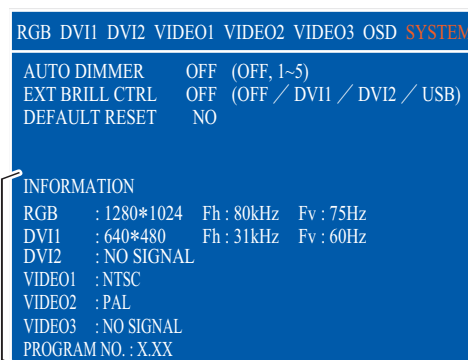

### 3. OPERATION

3. Press the ▲ or ▼ key to select [AUTO DIMMER].
4. Press the ◀ or ▶ key to select the adjustment interval.

[OFF]: Not adjusted automatically                      [3]: Every minute  
[1]: Every two seconds                                      [4]: Every three minutes  
[2]: Every 30 seconds                                        [5]: Every five minutes

5. Press the **MENU** key to close the menu.

### 3.6.2 How to adjust the brilliance from the external equipment

When FAR-21x7 series is connected to the [DVI-D1] or [DVI-D2] port, you can adjust the brilliance of the display unit from the FAR-21x7 series connected.

**Note:** The auto dimmer must be off to use this feature.

1. Press the **MENU** key to show the main menu.
2. Press the ▶ key to select [SYSTEM].
3. Press the ▲ or ▼ key to select [EXT BRILL CTRL].
4. Press the ◀ or ▶ key to set the desired input item.  
[OFF]: You can not adjust the brilliance from the external equipment.  
[DVI1]: When the DVI1 is displayed, the brilliance signal from DVI-D1 port controls this display's brilliance. The ⏻/BRILL key is available for the screen other than the DVI1.  
[DVI2]: When the DVI2 is displayed, the brilliance signal input from DVI-D2 port controls this display's brilliance. The ⏻/BRILL key is available for the screen other than the DVI2.  
[USB]: This is not available.
5. Press the **MENU** key to close the menu.

### 3.6.3 How to clear the memory

You can clear the memory to restore the default settings.

1. Press the **MENU** key to show the main menu.
2. Press the ▶ key to select [SYSTEM].
3. Press the ▲ or ▼ key to select [DEFAULT RESET].
4. Press the ▶ key.  
The display is changed to "YES" from "NO".

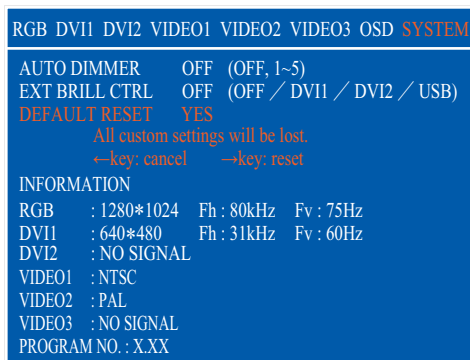

**Note:** To cancel, press the ◀ key. The display is changed to "NO" from "YES".

5. Press the ▶ key to select "reset".

# 4. MAINTENANCE, TROUBLESHOOTING

---

## NOTICE

**Do not apply paint, anti-corrosive sealant or contact spray to coating or plastic parts of the equipment.**

Those items contain organic solvents that can damage coating and plastic parts, especially plastic connectors.

## 4.1 Maintenance

### Routine maintenance

Regular maintenance is important for good performance. Check the following on a regular basis to keep the equipment in good condition.

- Check that the connectors at the bottom of the display unit are tightly fastened.
- Check the ground wire and ground terminal for rust. Clean if necessary. Confirm that the ground wire is tightly fastened.
- Remove dust and dirt from the display unit with a dry, soft cloth. Do not use chemical cleaners to clean any part of the display unit. They can remove paint and markings.
- Wipe the LCD carefully to prevent scratching, using LCD cleaning cloth (supplied as accessory). To remove dirt or salt deposits, use an LCD cleaner, wiping slowly with tissue paper so as to dissolve the dirt or salt. Change paper frequently so the salt or dirt will not scratch the LCD. Do not use solvents such as thinner, acetone or benzene for cleaning. Also, do not use degreaser or antifog solution, as they can strip the coating from the LCD.

### Fuse replacement

The fuse in the fuse holder on the power cable protects the equipment from internal fault. If the fuse blows, find the cause before you replace it. If the fuse blows again after replacement, request service.



## WARNING

**Use the proper fuse.**

Use of a wrong fuse can cause fire or damage to the equipment.

Name	Type	Code Number	Remarks
Fuse	FGBO 125V 10A PBF	000-155-826-10	12 VDC
Fuse	FGBO-A 125V 5A PBF	000-155-853-10	24 VDC

## 4. MAINTENANCE, TROUBLESHOOTING

### **LCD replacement**

The life of the LCD is approximately 60,000 hours. The actual numbers of hours depends on ambient temperature and humidity. When the brilliance cannot be raised sufficiently, replace the LCD.



### **Fan replacement**

The life of the fan is approximately 40,000 hours. The actual numbers of hours depends on ambient temperature. When the fan cannot be rotated sufficiently, the message "FAN1 ERROR" is shown. Turn off the power and contact your dealer to request replacement of the fan.

## 4.2 Troubleshooting

See the following table to find the possible causes and the actions to restore normal operation. If repair of the equipment is necessary, report the result of the troubleshooting to the service technician.

### *Troubleshooting*

<b>Case</b>	<b>Remedy</b>
You can not turn on the power.	<ul style="list-style-type: none"><li>• Check the setting for the slide switch. See section 1.7.</li><li>• Check the battery voltage with a multimeter.</li><li>• Check the fuse on the power cable.</li><li>• Fasten the power cable tightly.</li></ul>
You can not turn off the power.	<ul style="list-style-type: none"><li>• Press and hold the /BRILL key for eight seconds.</li><li>• When the slide switch is set to ON, turn off the external equipment connected.</li></ul>
No picture	<ul style="list-style-type: none"><li>• Fasten the cables tightly.</li><li>• Check the input signal. See section 3.6.</li></ul>
You can not operate any key except the  /BRILL key.	Cancel the key lock function. See paragraph 3.2.2.

## **SPECIFICATIONS OF MARINE DISPLAY MU-150HD**

### **1 GENERAL**

1.1	Display	15-inch color LCD
1.2	Effective area	304 x 228 mm approx.
1.3	Resolution	XGA (1024 x 768)
1.4	Brightness	1,000 cd/m <sup>2</sup> typical
1.5	Contrast	600: 1
1.6	View angle	160° typical (left/right and up/down: 80° or more)
1.7	Input signal	
	RGB analog	1 port, Non-interlace, RGB signal: 0.7 Vp-p, Sync. signal: TTL level
	DVI-D	2 port, DVI-standard, VESA DDC2B
	Composite	3 port, NTSC/PAL-standard, Video signal: 0.7 Vp-p

### **2 POWER SUPPLY**

12-24 VDC: 4.5-2.2 A

### **3 ENVIRONMENTAL CONDITION**



3.1	Ambient temperature	-15°C to +55°C
3.2	Relative humidity	93% at 40°C
3.3	Degree of protection	IP56 (CFR46, front panel), IP22 (chassis)
3.4	Vibration	IEC 60945-4

### **4 UNIT COLOR**

N2.5

**FURUNO**

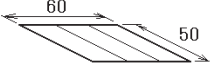
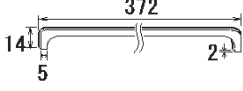
CODE NO.	001-080-770-00	26AD-X-9402 -0
TYPE	CP26-01302	1/1

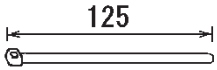
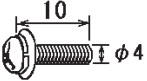
工事材料表 INSTALLATION MATERIALS		MU-150HD			
番号 NO.	名称 NAME	略図 OUTLINE	型名/規格 DESCRIPTIONS	数量 Q'TY	用途/備考 REMARKS
1	ヒューズ*ハリマーク FUSE LABEL		03-153-1312-0 ROHS CODE NO. 100-292-140-10	1	
2	Fマウントスポンジ* H15 FLUSH MOUNTING SPONGE H 15		26-005-2123-0 CODE NO. 100-351-280-10	2	
3	Fマウントスポンジ* V15 FLUSH MOUNTING SPONGE V 15		26-005-2124-0 CODE NO. 100-351-290-10	2	
4	コンベックス CONVEX		CV-125N CODE NO. 000-172-164-10	4	
5	ナベ*セムズB WASHER HEAD SCREW *B*		M4X10 SUS304 CODE NO. 000-163-836-10	6	

型式/コード番号が2段の場合、下段より上段に代わる過渡期品であり、どちらかが入っています。なお、品質は変わりません。

TWO TYPES AND CODES MAY BE LISTED FOR AN ITEM. THE LOWER PRODUCT MAY BE SHIPPED IN PLACE OF THE UPPER PRODUCT. QUALITY IS THE SAME.

(略図の寸法は、参考値です。 DIMENSIONS IN DRAWING FOR REFERENCE ONLY.)

表2 TABLE 2

フード	HOOD	B (mm)	D (mm)
なし	BLANK	6	364
あり	ATTACHED	7	368



表 1 TABLE 1

寸法区分 (mm) DIMENSION	公差 (mm) TOLERANCE
$L \leq 50$	$\pm 1.5$
$50 < L \leq 100$	$\pm 2.5$
$100 < L \leq 500$	$\pm 3$

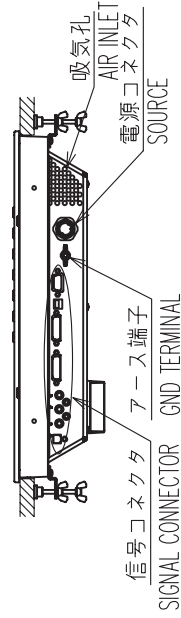
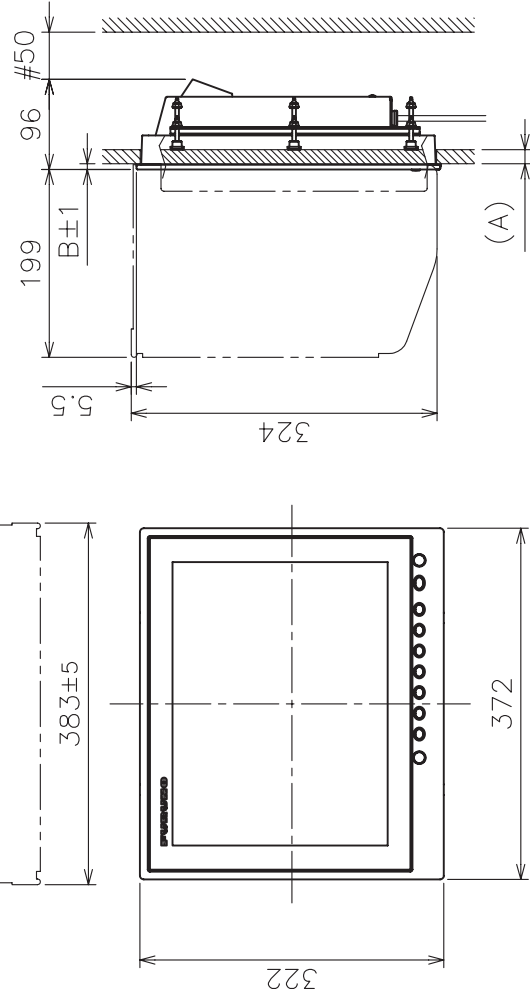
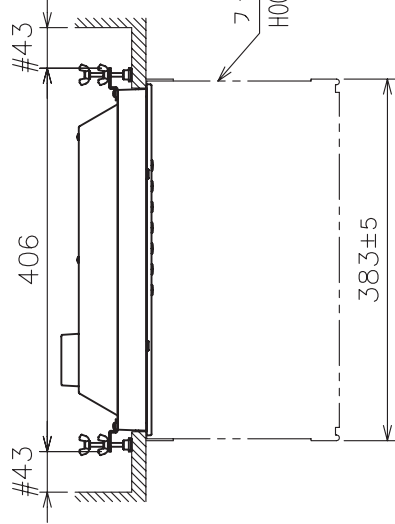
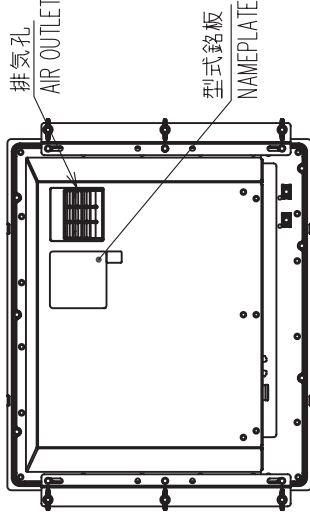
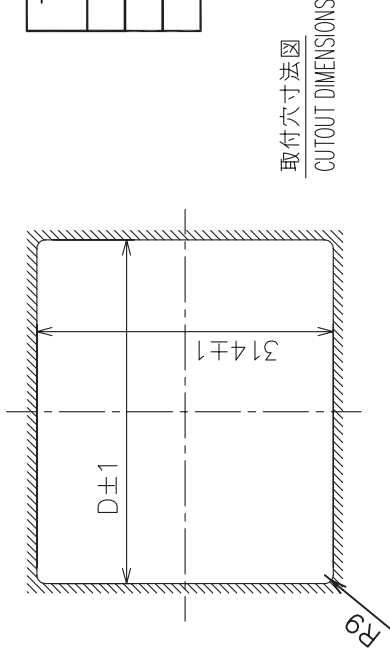

NOTE

- TABLE 1 INDICATES TOLERANCE OF DIMENSIONS WHICH IS NOT SPECIFIED.
- #: MINIMUM SERVICE CLEARANCE.
- THE BULKHEAD THICKNESS(A):  $10 \leq A \leq 20$ .
- SEE TABLE 2 FOR DIMENSIONS OF B AND D.

注 記

- 指定外の寸法公差は表 1 による。
- #印寸法は最小サービス空間寸法とする。
- 壁の厚さ (A) は最小 10、最大 20 とする。
- B, D の寸法は表 2 による。

DRAWN	19/Feb/10	I. YAMASAKI	TITLE	MU-150HD
CHECKED	22/Feb/10	I. TAKENO	名称	15型カラー-LCD表示器 (埋込装備S)
APPROVED	8/Mar/10	R. Esumi	外寸図	
SCALE	1/8	質量はオプションを含まず。 MASS W/O OPTION.	NAME	MARINE DISPLAY (FLUSH MOUNT S)
DWG.No.	C4456-G01-B	REF.No.	26-005-200G-2	OUTLINE DRAWING



表 1 TABLE 1

寸法区分 (mm) DIMENSION	公差 (mm) TOLERANCE
L ≤ 50	±1.5
50 < L ≤ 100	±2.5
100 < L ≤ 500	±3

NOTE

1. TABLE 1 INDICATES TOLERANCE OF DIMENSIONS WHICH IS NOT SPECIFIED.
2. #: MINIMUM SERVICE CLEARANCE.
3. USE TAPPING SCREWS φ5x20 FOR FIXING THE UNIT.
4. HOOD (OPTION) IS NOT APPLICABLE.

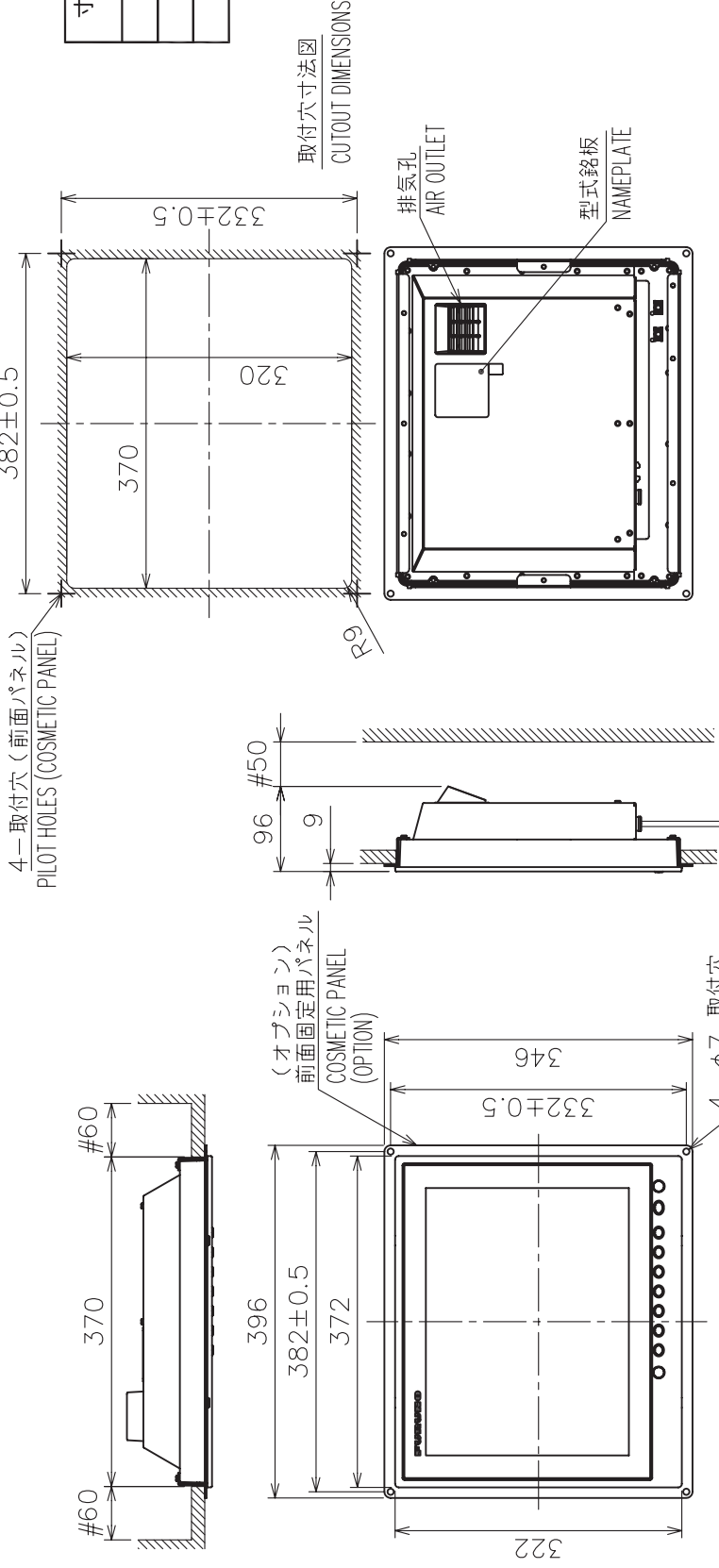
注 記

- 1) 指定外の寸法公差は表 1 による。
- 2) #印は最小サービス空間寸法とする。
- 3) 取付ネジはトラスタップピンネジ呼び径5×20を使用のこと。
- 4) フード (オプション) 装着は不可。

DRAWN	19/Feb/10	I. YAMASAKI	TITLE	MU-150HD
CHECKED	22/Feb/10	I. TAKENO	名称	15型カラーLCD表示器 (埋込装備F)
APPROVED	8/Mar/10	R. Esumi	外寸図	
SCALE	1/8	WASS 5.4 1/100 kg	NAME	MARINE DISPLAY (FLUSH MOUNT F)
DWG.No.	C4456-G03-B	REF.No.	26-005-230G-1	OUTLINE DRAWING

表 1 TABLE 1

寸法区分 (mm) DIMENSION	公差 (mm) TOLERANCE
L ≤ 50	± 1.5
50 < L ≤ 100	± 2.5
100 < L ≤ 500	± 3

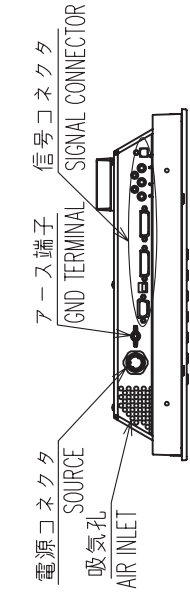

矢視 A  
VIEW A

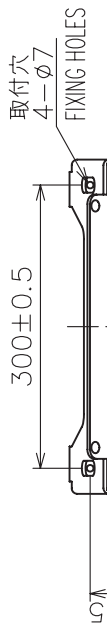

フード (オプション)  
HOOD (OPTION)

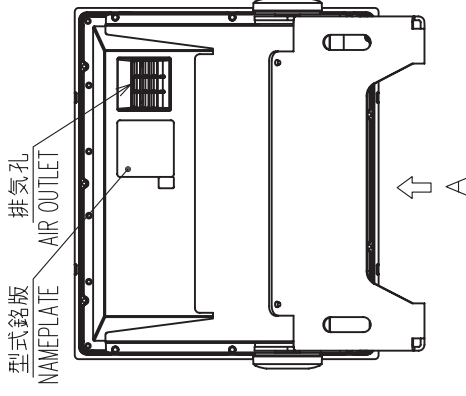
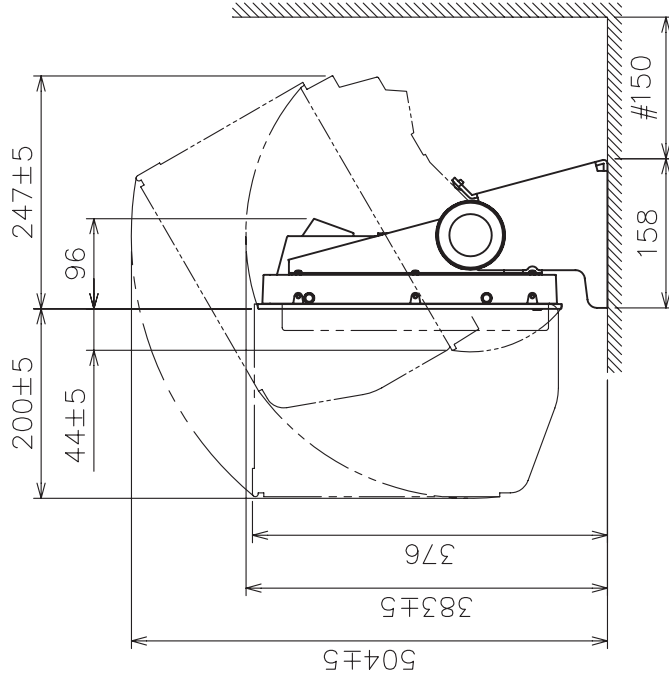

注 記

- 1) 指定外の寸法公差は表 1 による。
- 2) #印寸法は最小サービスペース寸法とする。
- 3) 取付用ネジはトラスタツピンネジ呼び径5×20を使用のこと。

NOTE

1. TABLE 1 INDICATES TOLERANCE OF DIMENSIONS WHICH IS NOT SPECIFIED.
2. # MINIMUM SERVICE CLEARANCE.
3. USE TAPPING SCREWS φ5x20 FOR FIXING THE UNIT.

DRAWN	16/Feb/10 I. YAMASAKI	TITLE	MU-150HD
CHECKED	16/Feb/10 I. TAKENO	名称	15型カラー-LCD表示器 (卓上装備)
APPROVED	8/Mar/10 R. Esumi	外寸図	
SCALE	1/8 MASS 7.4 質量はオプションを含まず。 kg MASS W/O OPTION.	NAME	MARINE DISPLAY (TABLETOP MOUNT)
DWG.No.	C4456-G02-B	REF.No.	26-005-210G-2
		OUTLINE DRAWING	

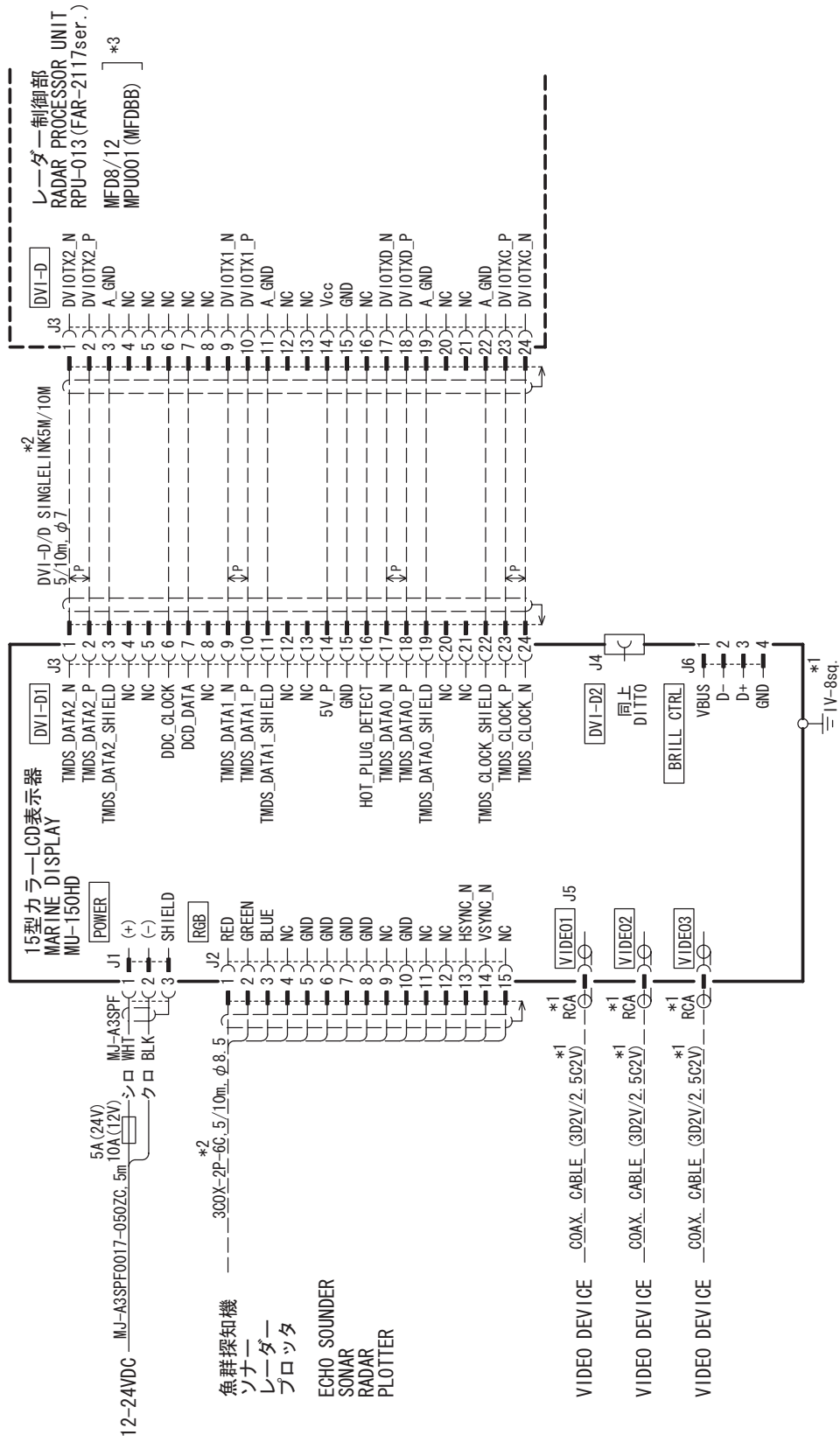

**注記**  
\*1) 造船所手配。  
\*2) オプション。  
\*3) 輸出仕様のみ。

**NOTE**  
\*1: SHIPYARD SUPPLY.  
\*2: OPTION.  
\*3: FOR EXPORT ONLY.

DRAWN	15/Dec/09	T. YAMASAKI	TITLE	MU-150HD
CHECKED	15/Dec/09	T. TAKENO	名称	15型カラーLCD表示器
APPROVED	8/Jan/10	R. Esumi	相互結線図	
SCALE	1/25	kg	NAME	MARINE DISPLAY
DWG No.	C4456-C01-B	REF. No.	26-005-5000-0	INTERCONNECTION DIAGRAM