

FURUNO

OPERATOR'S MANUAL

6" ECHO SOUNDER

MODEL LS-6100



FURUNO ELECTRIC CO., LTD.
NISHINOMIYA, JAPAN

© **FURUNO ELECTRIC CO., LTD.**

9-52 Ashihara-cho,
Nishinomiya, Japan

Telephone : 0798-65-2111

Telefax : 0798-65-4200

Your Local Agent/Dealer

All rights reserved.

Printed in Japan

PUB.No. OME-23690

(DAMI) LS-6100

FIRST EDITION : FEB. 2002

C : JUN. 10,2002



* 0 0 0 8 0 9 2 6 5 0 2 *



* O M E 2 3 6 9 0 C 0 0 *

TABLE OF CONTENTS

FOREWORD	iii	2. SYSTEM & INSTALLATION MENUS	18
SYSTEM OVERVIEW	iv	2.1 System Menu.....	18
1. OPERATION	1	2.2 Installation Menu	20
1.1 Control Description	1	3. MAINTENANCE,	
1.2 Turning the Power On/Off	1	TROUBLESHOOTING	22
1.3 Adjusting Display Contrast, Brilliance	2	3.1 Maintenance	22
1.4 Choosing a Display, Frequency	2	3.2 Cleaning the Display Unit.....	22
1.5 Menu Operating Procedure	5	3.3 Transducer Maintenance	22
1.6 Automatic Operation	5	3.4 Replacing the Fuse.....	22
1.7 Manual Operation	6	3.5 Battery Voltage Alert	22
1.8 Choosing Picture Advance Speed.....	7	3.6 Troubleshooting.....	23
1.9 Measuring Depth.....	8	3.7 Diagnostics.....	23
1.10 A-scope Display	8	3.8 Test Pattern	24
1.11 Suppressing Interference	9	4. INSTALLATION	25
1.12 Suppressing Low Level Noise	9	4.1 Display Unit	25
1.13 Erasing Weak Echoes.....	10	4.2 Thru-hull Mount Transducer.....	25
1.14 White Line.....	10	4.3 Transom Mount Transducer.....	27
1.15 Waypoints	10	4.4 Inside-hull Transducer	29
1.16 PROG Key	12	4.5 Optional Triducer	30
1.17 Picture Color (Hue)	13	4.6 Optional Water Temperature/Speed Sensor	34
1.18 Deep Gain.....	13	4.7 Wiring	34
1.19 Alarms	13	4.8 IEC 61162-1 Data Sentences.....	36
1.20 Resetting Trip Distance	15	SPECIFICATIONS	SP-1
1.21 Setting the Draft	15	OUTLINE DRAWING	
1.22 Gain Compensation	15	INTERCONNECTION DIAGRAM	
1.23 Setting Up Nav Data Displays	16		



SAFETY INSTRUCTIONS

Safety Instructions for the Operator



WARNING

Do not open the equipment.

There are no user-serviceable parts inside.

Do not disassemble or modify the equipment.

Fire, electrical shock or serious injury can result.

Immediately turn off the power at the switchboard if the equipment is emitting smoke or fire.

Continued use of the equipment can cause fire or electrical shock. Contact a FURUNO agent for service.

Do not maneuver the vessel based on the depth indication alone.

Grounding may result.

Use the proper fuse.

Fuse rating is shown on the equipment. Use of a wrong fuse can result in damage to the equipment.



CAUTION

Do not turn on the equipment with the transducer out of water.

The transducer may be damaged.

The picture is not refreshed when picture advancement is stopped.

Maneuvering the vessel in this condition may result in a dangerous situation.

Use the proper gain setting.

Incorrect gain may produce wrong depth indication, possibly resulting in a dangerous situation. See "Adjusting the gain" on page 7 for details.

NOTICE

The high quality LCD shows 99.99% of its pixels. The remaining .01% may drop out or brighten, due to the property of the LCD, however this is not a sign of malfunction.

A warning label is attached to the equipment. Do not remove the label. If the label is missing or damaged, contact a FURUNO agent or dealer.

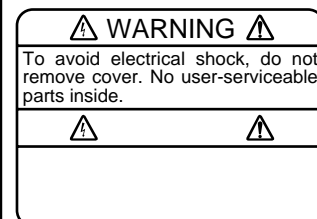

Name: Warning Label (1)

Type: 86-003-1011-1

Code No.: 100-236-231

Safety Instructions for the Installer



WARNING

Turn off the power at the switchboard before beginning the installation.

Fire or electrical shock can result if the power is left on.

Be sure no water leaks in at the transducer or sensor mounting location.

Water leakage can sink the vessel. Also confirm that the transducer and sensor will not loosen by ship's vibration. The installer of the equipment is solely responsible for the proper installation of the equipment. FURUNO will assume no responsibility for any damage associated with improper installation.

Use the specified power cable.

Use of other power cable may result in fire.



CAUTION

Do not install the equipment where air bubbles and noise are present.

Performance will be affected.

The following are guidelines for handling of the transducer cable.

- Do not locate near oils and fuels.
- Locate it in a safe place.
- Do not paint the cable.

The sheath of the cable is made of chloroprene rubber (or polychloride vinyl). For this reason do not paint the cable.

Observe the following compass safe distances to prevent interference to a magnetic compass:

	Standard compass	Steering compass
Display unit	0.5 m	0.35 m

FOREWORD

A Word to LS-6100 Owners

Congratulations on your choice of the FURUNO LS-6100 6" Echo Sounder. We are confident you will see why the FURUNO name has become synonymous with quality and reliability.

For over 50 years FURUNO Electric Company has enjoyed an enviable reputation for innovative and dependable marine electronics equipment. This dedication to excellence is furthered by our extensive global network of agents and dealers.

This equipment is designed and constructed to meet the rigorous demands of the marine environment. However, no machine can perform its intended function unless operated and maintained properly. Please carefully read and follow the recommended procedures for operation and maintenance.

We would appreciate hearing from you, the end-user, about whether we are achieving our purposes.

Thank you for considering and purchasing FURUNO equipment.

Features

The FURUNO LS-6100 is a dual frequency (50 kHz, 200 kHz) monochrome LCD echo sounder. Comprised of a display unit and a transducer, the LS-6100 displays underwater conditions on a bright 6-inch monochrome LCD.

The main features of the LS-6100 are

- Compact design permits installation where space is limited.
- Bright 6-inch monochrome LCD gives excellent readability even in broad daylight.
- Wide variety of display modes: single frequency, dual frequency, bottom-lock, marker-zoom, bottom-zoom, and nav data.
- Automatic function permits unattended adjustment of range and gain. The range scale and gain automatically change to display the bottom in the darkest gray tone on the lower half of the screen.
- User-programmable nav data displays provide analog and digital nav data.
- Alarms: Bottom, Fish (bottom-lock and normal), Speed, Water Temperature and Arrival. (Speed and arrival alarms require appropriate sensor; water temperature alarm requires water temperature data.)
- A-scope display helps discern echo amplitude.
- White line feature helps discriminate fish lying near the bottom.
- Destination waypoint feature provides range, bearing, and time-to-go to destination waypoint.
- Waterproof construction permits installation on open bridge.

SYSTEM OVERVIEW

System configuration

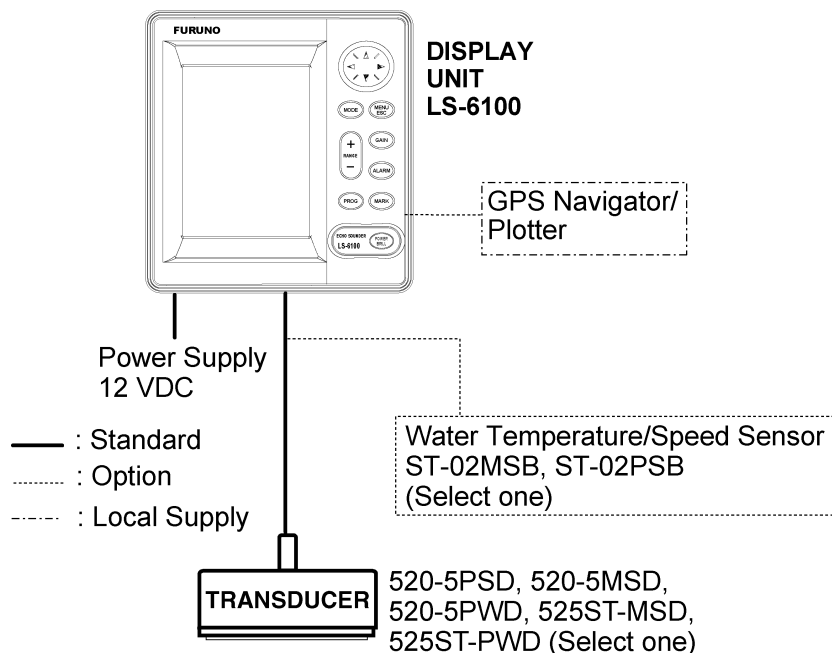

Equipment lists

Standard supply

Name	Type	Code No.	Qty	Remarks
Display Unit	LS-6100	—	1	
Transducer	520-5PSD	000-015-204	Select one	Thru-hull mount
	520-5MSD	000-015-212		Thru-hull mount
	520-5PWD	000-015-126		Transom mount
Triducer (transducer plus spd/temp sensor)	525ST-MSD	000-015-263		Thru-hull mount
	525ST-PWD	000-015-261		Transom mount
Installation Materials (CP02-07000)	<ul style="list-style-type: none"> Tapping screw (4 pcs., 5 x 20 SUS304, 000-802-081) Washer head screw B (4 pcs., M4 x 20 SUS304, 000-804-742) Cable assy. (1 pc., MJ-A15A3F0003-030, 000-145-513) 			
Spare Parts (SP02-04500)	Fuse (1 pc., 61NM-125V, 1A, Code No. 000-145-864)			
Template	Type 02-139-1035-2, Code No. 100-298-502, 1 pc., for flush mount			

Optional equipment

Name	Type	Code No.	Qty	Remarks
NMEA Cable	MJ-A15A7F0004-005	000-145-690	1	0.5 m, for wind sensor
	MJ-A15A7F0005-020	000-145-691	1	2 m, w/o +12V line
Conversion Cable	02S4147	000-141-082	1	For spd/temp sensor
Water Temperature & Speed Sensor	ST-02MSB	000-137-986	Select one	Thru-hull type
	ST-02PSB	000-137-987		
Inner Hull Kit	22S0191	000-802-598	1	

1. OPERATION

1.1 Control Description

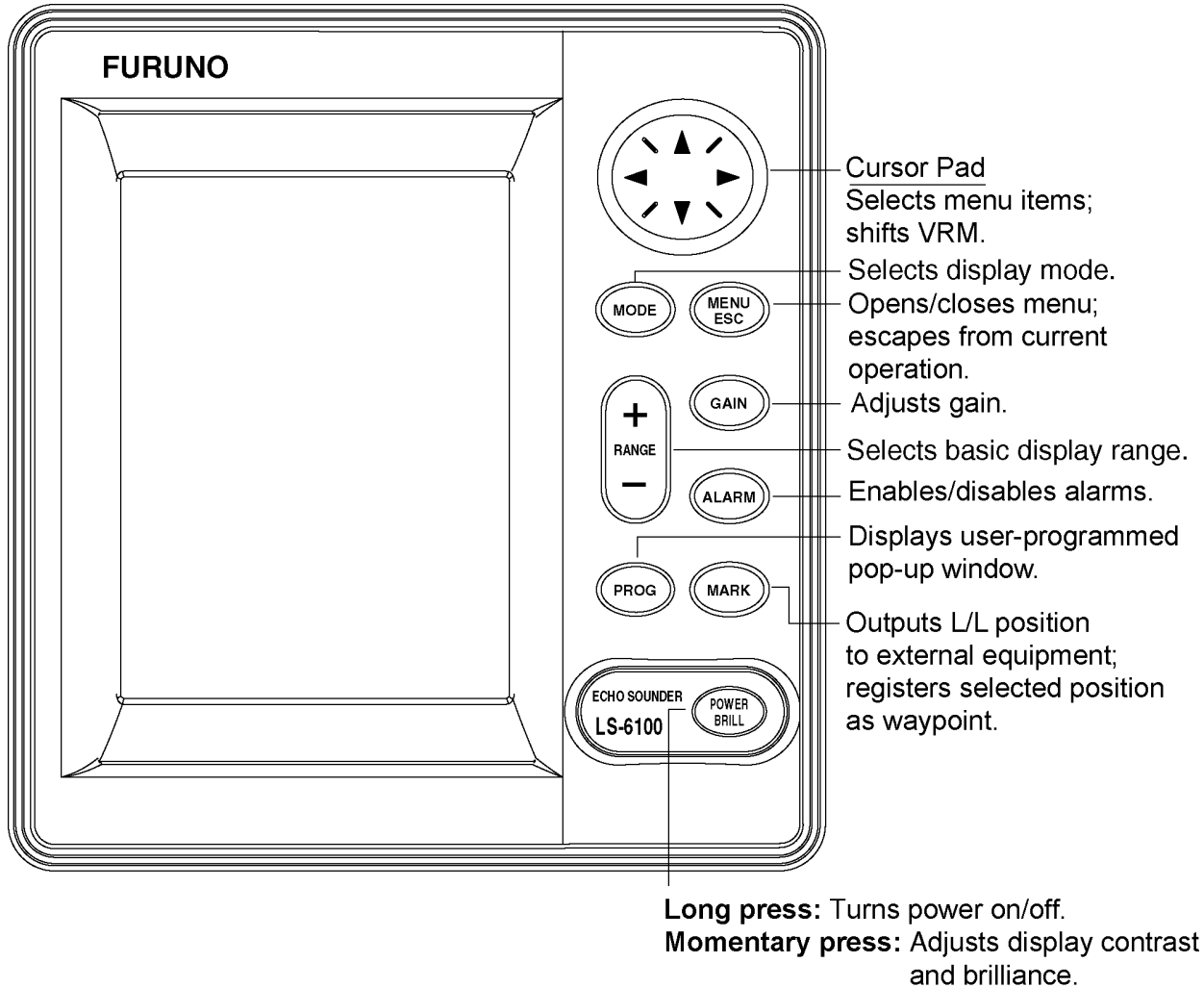

Display unit

How to remove the hard cover

Place your thumbs at the center of the cover, and then lift the cover while pressing it with your thumbs.

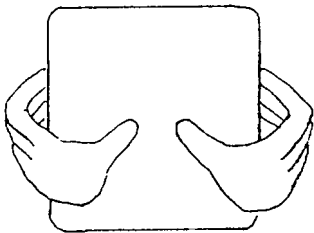

1.2 Turning the Power On/Off

Press the [POWER/BRILL] key more than one second to turn on the power. The unit beeps, the startup screen appears, and then the equipment checks the ROM and RAM for proper operation and displays program number. (If “NG” (No Good) appears, try to press any key except the [POWER/BRILL] key to start operation. However, the equipment may not work properly. Contact your dealer.) You may

press any key after the completion of the equipment check to start operation sooner.

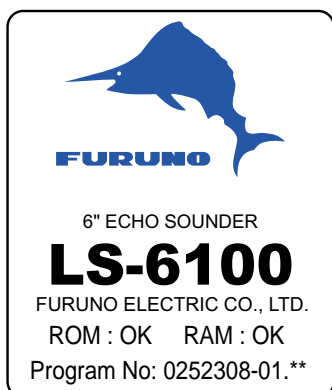

** Program version no.

Start-up screen

To turn off the power, press and hold down the [POWER/BRILL] key until the screen goes blank. The time remaining until power is turned off is counted down on the screen.

Note: The example screens shown in this manual may not match the screens you see on your display. The screen you see depends on your system configuration and equipment settings.

1.3 Adjusting Display Contrast, Brilliance

1. Press the [POWER/BRILL] key momentarily to show the brilliance/contrast adjustment window.



Brilliance/contrast adjustment window

2. For contrast, press the [POWER/BRILL] key to adjust contrast cyclically. (You may also use ◀ or ▶ on the Cursor Pad to adjust contrast.)
3. To adjust brilliance, use ▲ or ▼.
4. Press the [MENU/ESC] key to close the brilliance/contrast adjustment window.

Note 1 : Setting windows other than those on menus are erased if there is no operation within about seven seconds.

Note 2: When the power is reapplied after turning off the equipment with minimum brilliance, minimum brilliance will be set after the equipment goes through its initial start up. Adjust the brilliance as necessary.

1.4 Choosing a Display, Frequency

Seven displays are available: single frequency (50 or 200 kHz), dual frequency, marker-zoom, bottom-zoom, bottom-lock, and nav data (two displays).

1. Press the [MODE] key to show the mode selection window.

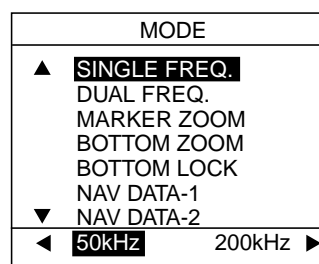

Mode selection window

2. Press the [MODE] key again within seven seconds to choose a mode. You may also choose a mode with ▲ or ▼.
3. For modes other than DUAL FREQ, choose frequency; press ◀ for 50 kHz; ▶ for 200 kHz.
4. Press the [MENU/ESC] key to close the menu.

Single frequency display

50 kHz

The sounder uses ultrasonic signals to detect bottom conditions. The lower the frequency of the signal, the wider the detection area. Therefore, the 50 kHz frequency is useful for general detection and judging bottom condition.

200 kHz

The higher the frequency of the ultrasonic signal the better the resolution. For this reason the 200 kHz frequency is ideal for detailed observation of fish schools.

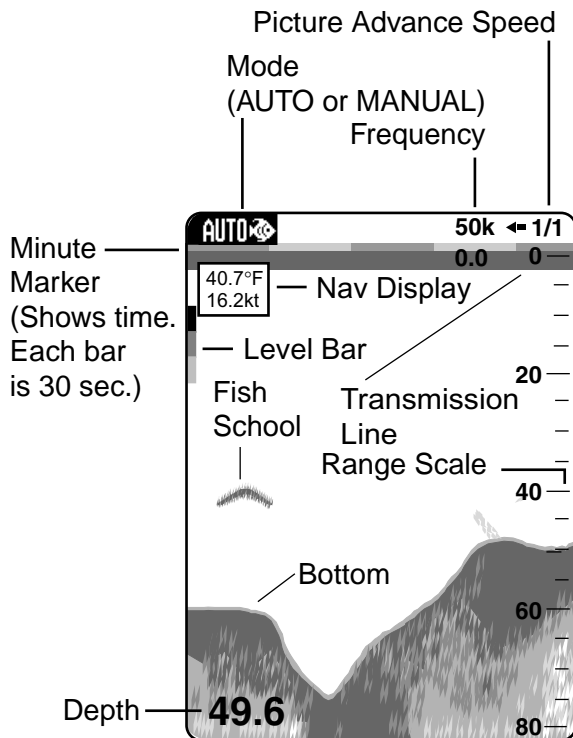
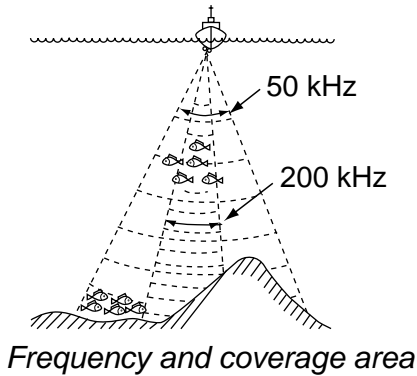

Typical 50 kHz display

Dual frequency display

The 50 kHz picture appears on the left; the 200 kHz picture on the right. This display is useful for comparing the same picture with two different transmitting frequencies.

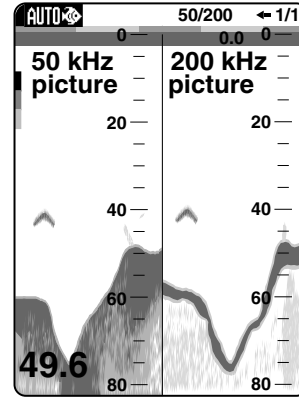

Dual frequency display

Marker-zoom display

This mode expands chosen area of the normal picture to full vertical size of the screen on the left-half window. You may specify the portion to expand by operating the VRM (Variable Range Marker), which you can shift with ▲ or ▼. The area between the VRM and zoom range marker is expanded.

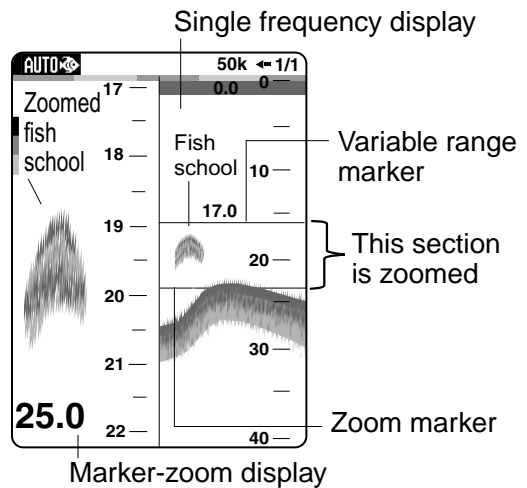

Marker-zoom display

Bottom-zoom display

This mode expands bottom and bottom fish in the range width set with ZOOM RANGE on page 3 of the SYSTEM menu. This mode is useful for determining bottom contour.

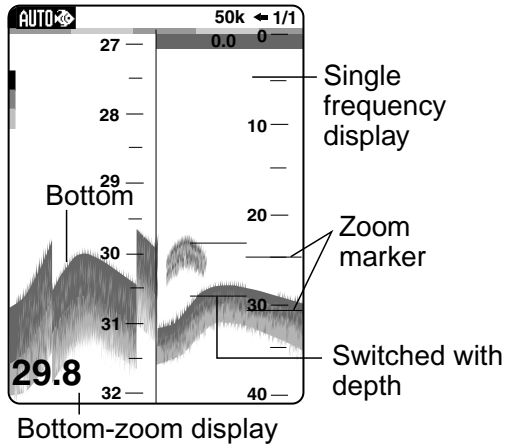

Bottom-zoom display

Bottom-lock display

The bottom-lock display provides a normal picture on the right half of the screen and a 15 feet (5 meter)* wide layer in contact with the bottom is expanded onto the left half of the screen. This mode is useful for detecting bottom fish.

* = Operator selectable

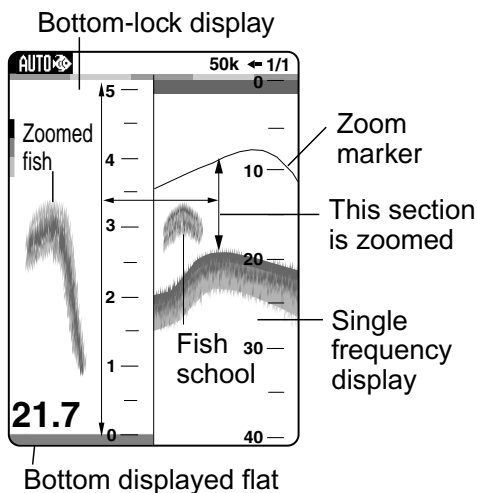

Bottom-lock display

Nav data displays

The nav data displays appear on the left 2/3 of the screen. Data other than depth requires appropriate sensor.

You can display between two and four items in a nav data display and choose the item and order and to display them. See paragraph 1.23 to choose the items to display and "NAV DATA-1" and "NAV DATA-2" in paragraph 2.1 to choose the number of items to display.

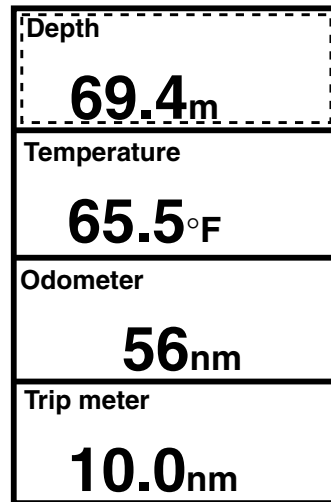

NAV DATA-1 display

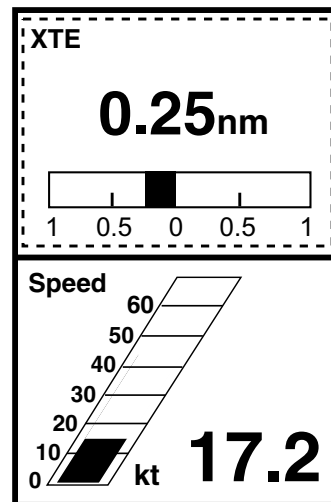

NAV DATA-2 display

Sample NAV DATA displays

1.5 Menu Operating Procedure

The LS-6100 has three menus: Main menu (referred to in text as “menu”), System and Installation. Below is the basic menu operating procedure.

1. Press the [MENU/ESC] key to open the menu. Page 1 or Page 2 of the menu appears depending on the page last used.

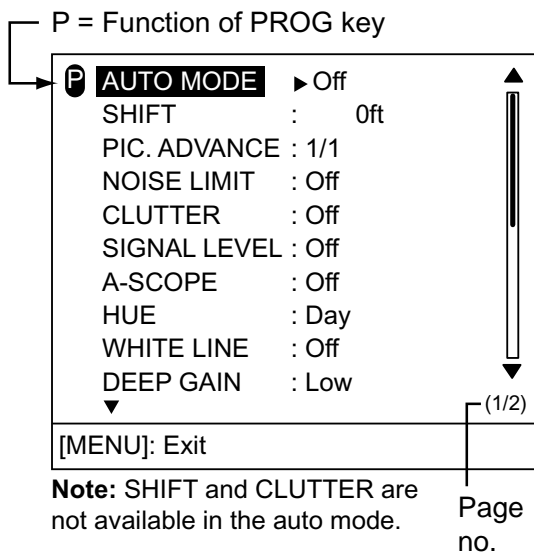

Menu, page 1

2. Use ▲ or ▼ to select an item. To view page 2 of the menu, press ▼ to show the display below.

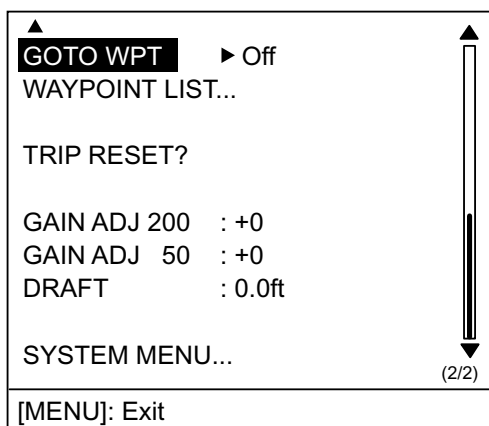

Menu, page 2

3. Press ► to show selected item’s options window. The example below shows the options window for AUTO MODE.

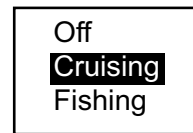

Auto mode options window

4. Use ▲ or ▼ to choose option or set numeric value.
5. Press the [MENU/ESC] key to close the menu, or press ◀ to continue menu operation.

1.6 Automatic Operation

How automatic operation works

The automatic function automatically chooses the proper gain, range scale and clutter. It works as follows:

- The range changes automatically to display the bottom echo on the screen.
- The gain is automatically adjusted to display the bottom echo in the darkest tone.
- Clutter (on the menu), which suppresses low-level noise, is automatically adjusted.

Choosing automatic operation

The automatic mode provides two choices of modes: cruising and fishing.

1. Press the [MENU/ESC] key to open the menu.
2. Choose AUTO MODE from page 1 of the menu.
3. Press ► to open the mode options window.
4. Choose Cruising or Fishing as appropriate.

“Cruising” is for tracking the bottom; “Fishing” is for searching fish schools. Since “Cruising” uses a higher clutter rejection setting than fishing, it is not recommended for fish detection - weak fish echoes may not be displayed. “Fishing” clearly displays weaker echoes.

5. Press the [MENU/ESC] key to close the menu.

The auto mode in use is shown as **AUTO** (Auto-Fishing) or **AUTO** (Auto-Cruising) at the top left corner on the screen.

Range offset

To display the bottom tail in detail in the automatic mode, offset the range as below.

1. Press the [+] or [-] key of the [RANGE] key.

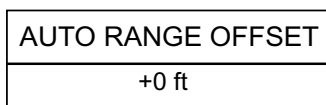

Auto range offset window

2. Press the [+] or [-] key of the [RANGE] key again to choose offset desired (range: -100 to +300 ft). Note that if the range is changed the offset is returned to "0".
3. Press the [MENU/ESC] key to finish.

Gain offset

Gain offset lets your override automatic gain adjustment.

1. Press the [GAIN] key.

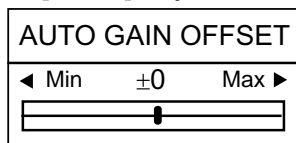

Auto gain offset window

2. Press ◀ or ▶ key to offset gain (setting range -5 to +5). The gain selected is shown at the top of the screen as G (Gain) + (or -) XX (offset).
3. Press the [MENU/ESC] key to finish.

1.7 Manual Operation

Choosing the manual mode

1. Press the [MENU/ESC] key to open the menu.
2. Press ▲ or ▼ to choose AUTO MODE from page 1 of the menu.
3. Press ► to show the options window.
4. Choose Off with ▲.
5. Press the [MENU/ESC] key to close the menu. "MANUAL" appears in reverse video at the top left corner on the screen.

Choosing range

The basic range and range shifting functions used together give you the means to choose the depth you can see on the screen. The basic range can be thought of as providing a "window" into the water column and range shifting as moving the "window" to the desired depth.

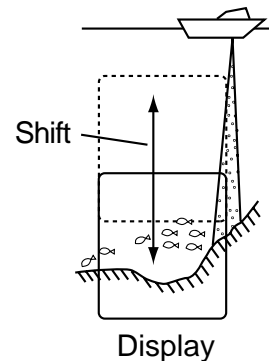

Range and display shift concept

Choosing basic range

The basic range may be chosen with the [RANGE] key from the eight ranges shown in the table on the next page. ("P/B" in the table means Passi/Braza.)

Table 1-1 Default ranges

Unit	Basic Range							
	1	2	3	4	5	6	7	8
meters	5	10	20	40	80	150	200	300
feet	15	30	60	120	200	400	600	1000
fathoms	3	5	10	20	40	80	120	200
P/B	3	5	10	30	50	100	150	200

1. Press the [+] or [-] key of the [RANGE] key and the display should now look something like the one below.
2. Press the [+] or [-] key of the [RANGE] key again to choose a basic range.

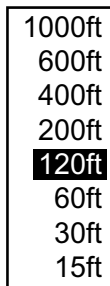

Basic ranges (default)

Shifting the range

The basic range may be shifted up or down in the manual mode as follows:

1. Press the [MENU/ESC] key to open the menu.
2. Choose SHIFT from page 1 of the menu.
3. Press ► to open the shift options window.



Shift window

4. Use ▲ or ▼ to choose amount of shift desired.
5. Press the [MENU/ESC] key to close the menu.

Note: The picture may not be displayed if the amount of shift is greater than actual depth.

Adjusting the gain

The [GAIN] key adjusts the sensitivity of the receiver. Generally, use a higher gain setting for greater depths and a lower setting for shallower waters.

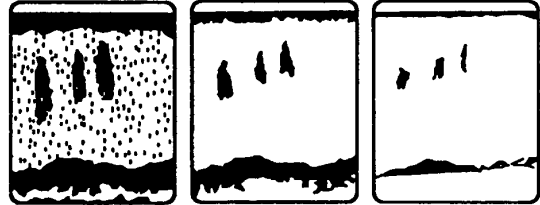

Gain too high Gain proper Gain too low

Examples of proper and improper gain

1. Press the [GAIN] key and the display shown below appears.

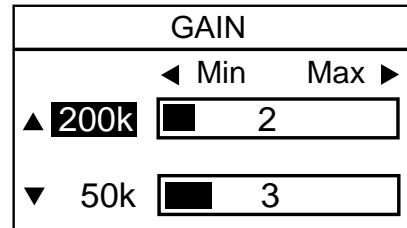

Gain adjustment window

2. When using the dual frequency display, press ▲ or ▼ to choose frequency.
3. Press the [GAIN] key to set. (You may also use ◀ or ▶.) Adjust so that a slight amount of noise remains on the screen.
4. Press the [MENU/ESC] key to close the gain adjustment window.

1.8 Choosing Picture Advance Speed

The picture advance speed determines how quickly the vertical scan lines run across the screen. When choosing a picture advance speed, keep in mind that a fast advance speed will expand the size of the fish school horizontally on the screen and a slow advance speed will contract it. Note that the picture is not refreshed when picture advancement is stopped. Therefore, use caution when steering the vessel under this condition.

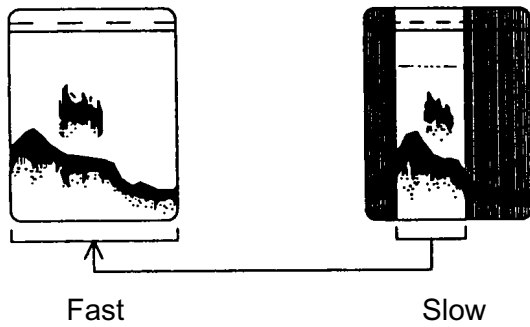

Picture and picture advancement speed

1. Press the [MENU/ESC] key to open the menu.
2. Choose PIC. ADVANCE from page 1 of the menu.
3. Press ► to show the options window.

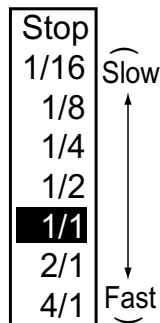

Picture advance options window

4. Use ▲ or ▼ to choose picture advance speed desired. The fractions in the options window denote the number of scan lines produced per transmission. For example, 1/8 means one scan line is produced every 8 transmissions. "Stop" freezes the display and it is convenient for observing an echo.
5. Press the [MENU/ESC] key to close the menu.

1.9 Measuring Depth

The VRM (Variable Range Marker) functions to measure the depth to fish schools, etc.

1. Press ▲ or ▼ to place the VRM on the object which you wish to measure range.
2. Read the VRM depth just above the VRM.

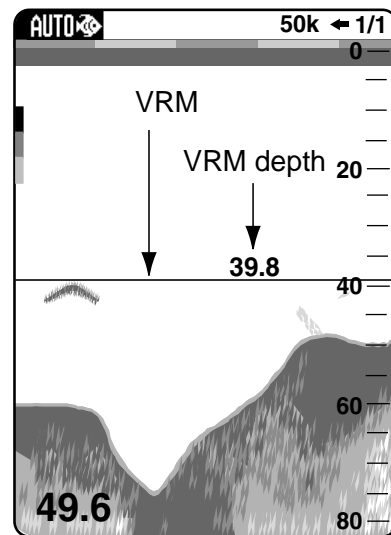

How to measure depth with the VRM

1.10 A-scope Display

This display shows echoes at each transmission with amplitudes and tone proportional to their intensities, on the right 1/4 of the screen. It is useful for estimating the kind of fish school and bottom composition.

Note: In the dual frequency display, the A-scope display is only available with the high frequency display.

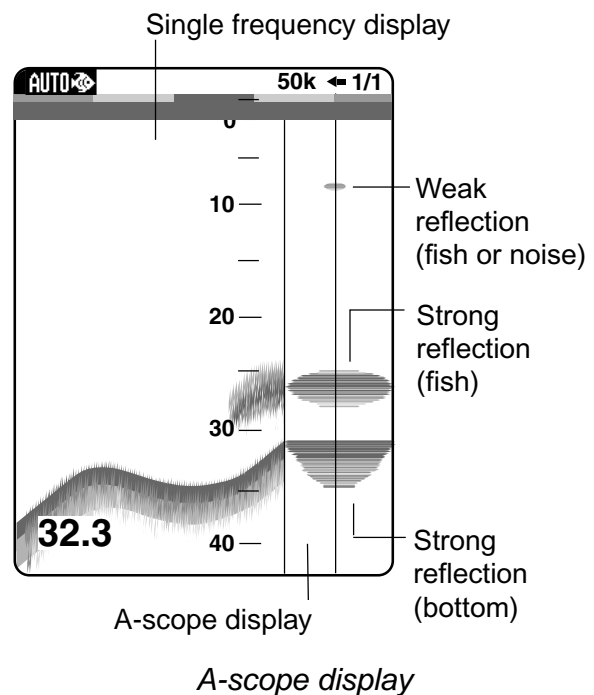

1. Press the [MENU/ESC] key to open the menu.
2. Press ▲ or ▼ to choose A-SCOPE from page 1 of the menu.
3. Press ► to show the options window.
4. Press ▲ or ▼ to choose the A-scope presentation type desired.
Normal: Display shows echoes at each transmission with amplitudes and tone proportional to their intensities
Peak: Peak-hold amplitude picture.
5. Press the [MENU/ESC] key to close the menu.
6. **To turn off the A-scope display,** choose Off at step 4 and then press the [MENU/ESC] key.

1.11 Suppressing Interference

Interference from other acoustic equipment operating nearby or other electronic equipment on your boat may show itself on the display as shown in the figure below. To suppress interference, do the following:

1. Press the [MENU/ESC] key to open the menu.
2. Use ▲ or ▼ to choose NOISE LIMIT from page 1 of the menu.
3. Press ► to show the options window.
4. Use ▲ or ▼ to choose the degree of suppression desired; Off, Low, Medium, or High (highest).
5. Press the [MENU/ESC] key to close the menu.



Interference from other sounder



Electrical interference

Forms of interference

Turn the noise limiter off when no interference exists, otherwise weak echoes may be missed.

1.12 Suppressing Low Level Noise

Low intensity “speckles” may appear over most of screen. This is mainly due to sediment in the water or noise. These can be suppressed by adjusting CLUTTER on the menu. When the automatic mode is on, clutter is automatically rejected. To suppress low level noise in manual sounder operation, do the following:

1. Press the [MENU/ESC] key to open the menu.
2. Use ▲ or ▼ to choose CLUTTER from page 1 of the menu.
3. Press ► to show the options window.
4. Use ▲ or ▼ to choose the degree of suppression desired; 1, 2, 3, 4, 5 or 6. The higher the number the greater the suppression.
5. Press the [MENU/ESC] key to close the menu.
6. **To turn off low-level noise suppression,** choose Off at step 4 and then press the [MENU/ESC] key.

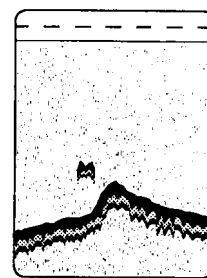

Clutter appearance

1.13 Erasing Weak Echoes

Sediment in the water or reflections from plankton may be painted on the display in low intensity tones.



Weak echoes

Appearance of weak echoes

These weak echoes may be erased as follows:

1. Press the [MENU/ESC] key to open the menu.
2. Use ▲ or ▼ to choose SIGNAL LEVEL from page 1 of the menu.
3. Press ► to show the options window.
4. Use ▲ or ▼ to choose the degree of suppression desired; Off, Low, or High (highest).
5. Press the [MENU/ESC] key to close the menu.
6. **To turn off the signal level function,** choose "Off" at step 4 and then press the [MENU/ESC] key.

1.14 White Line

The white line feature displays a leading edge of the bottom echo in white. This is useful for discriminating bottom fish near the bottom.

1. Press the [MENU/ESC] key to display the menu.
2. Use ▲ or ▼ to choose WHITE LINE from page 1 of the menu.
3. Press ► to show the options window.
4. Use ▲ or ▼ to choose Off, Tone or Mesh as appropriate. "Mesh" paints the white line in darker tone than "Tone."
5. Press the [MENU/ESC] key to close the menu.

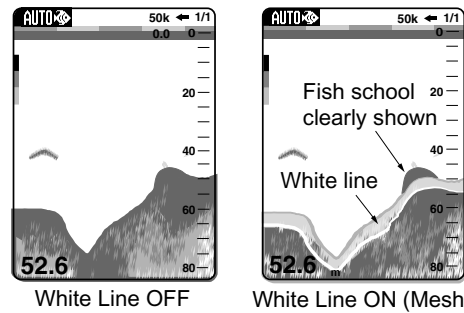

How white line works

1.15 Waypoints

Waypoints may be used to:

- Record the latitude and longitude position of an important echo. 12 points may be registered.
- Output a waypoint position to a plotter to mark position on its screen
- Find range, bearing and time-to-go to a location (waypoint)

Note: Requires latitude and longitude position from a navigator.

Registering a waypoint on the screen

1. Press the [MARK] key. The cursor appears along with waypoint entry instructions.

Note: If there is no position data the message "No position data!" appears. Check the navigator.

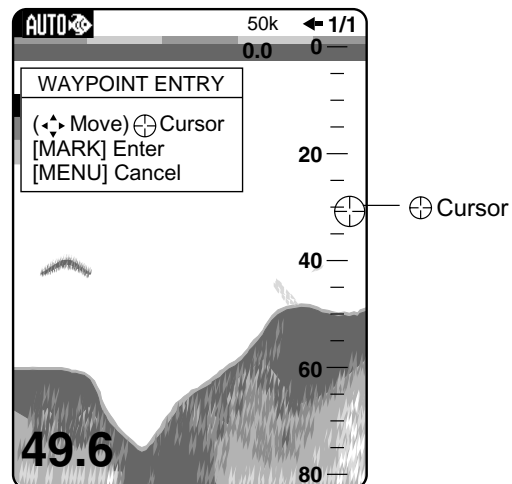

50 kHz display

- Use ▲ or ▼ to set the cursor where desired. Picture advancement is stopped until step 3 is completed.
- Press the [MARK] key again. The latitude and longitude position at the cursor is output to the navigator and a vertical line marks location. Further, the display shows the waypoint name (next sequential number) and position of the location selected at step 2.

WAYPOINT	
Name▶	05
Lat	: 34°22.796'N
Lon	: 136°07.264'E
Erase?	
[MENU]: Exit	

Waypoint data display

Note: If you attempt to enter 13th waypoint, the message “Memory full!” appears. In this case, erase an unwanted waypoint to enable entry.

- Press the [MENU/ESC] key to save the waypoint under the name shown, or go to step 5 to change its name.
- Press ► to open the waypoint name entry window.

WAYPOINT	
Name	01.....▶ENT
Lat	: 34°22.796'N
Lon	: 136°07.264'E
Erase?	
[MENU]: Exit	

Waypoint window, name entry

- Use ▲ or ▼ to set character; ◀ or ▶ to shift cursor. The name may consist of eight alphanumeric characters.

Note: Character order is 0→1...9→A→B...Z→0...

- Press ► to choose ENT.
- Press the [MENU/ESC] key to register the waypoint.

Registering waypoint from the waypoint list

- Press the [MENU/ESC] key to open the menu.
- Use ▲ or ▼ to choose WAYPOINT LIST from page 2 of the menu.
- Press ►.

WAYPOINT LIST	
01	
02	▶
03	

[MENU]: Exit	

Waypoint list

- Choose an empty waypoint and press ►. Press ► again.

NEW WAYPOINT	
Name	04.....▶ENT
Lat	: 34°22.796'N
Lon	: 136°07.264'E
Erase?	
[MENU]: Exit	

New waypoint window, name entry

- Use ▲ or ▼ to set character; ◀ or ▶ to shift cursor.
- Press ► to select ENT.
- Enter latitude and longitude, similar to how you entered waypoint name
- Press the [MENU/ESC] key to register the waypoint.

Setting destination waypoint

Set a destination waypoint to find range, bearing and time-to-go to that point. You can see range and bearing to a waypoint. Time-to-go is shown on the Time to Go digital display.

- Press the [MENU/ESC] key to open the menu.

- Use ▲ or ▼ to choose GOTO WPT from page 2 of the menu.
- Press ► to open the waypoints list.

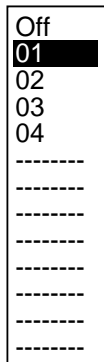

Waypoint list

- Use ▲ or ▼ to choose a waypoint.
- Press the [MENU/ESC] key to close the menu.

Editing waypoints

- Press the [MENU/ESC] key to open the menu.
- Use ▲ or ▼ to choose WAYPOINT LIST from page 2 of the menu.
- Press ► to open the waypoints list.
- Use ▲ or ▼ to choose a waypoint and press ►.
- Use ▲ or ▼ to choose the item to edit; name, latitude or longitude.
- Press ► to open the data entry window.
- Use ▲ or ▼ to set character; ◀ or ▶ to choose location.
- Press ► to choose ENT.
- Press the [MENU/ESC] key to close the menu.

Erasing waypoints

- Press the [MENU/ESC] key.
- Use ▲ or ▼ to choose WAYPOINT LIST from page 2 of the menu.
- Press ► to open the waypoints list.
- Use ▲ or ▼ to choose the waypoint to erase, and then press ►.

Note: You cannot erase a waypoint which is selected as “GOTO WPT.”

- Press ▼ to choose “Erase.”
- Press ► to open the options window.

- Press ▲ to select YES to erase the waypoint. The waypoint list appears, with the erased waypoint blank.
- Press the [MENU/ESC] key twice to close the menu.

1.16 PROG Key

The [PROG] key provides for instant display of a user-programmed options window from page 1 of the menu

Using the PROG key

- Press the [PROG] key. The pop-up window corresponding to the item programmed appears. In the example below the auto mode options (default [PROG] key setting) is shown.

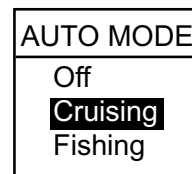

Auto mode options window

- Use ▲ or ▼ to select option or adjust setting.
- Press the [MENU/ESC] to close the window.

Registering function

- Press the [MENU/ESC] key to show the menu.
- Choose the item on page 1 of the menu that you wish to use.
- Press and hold down the [PROG] key (about three seconds) until you hear a beep. The “P” mark moves to item selected.
- Press the [MENU/ESC] key to close the menu.

1.17 Picture Color (Hue)

Two picture color arrangements are available: Day and Night. Day shows echoes on a white background; Night shows them on a black background.

1. Press the [MENU/ESC] key to display the menu.
2. Use ▲ or ▼ to choose HUE from page 1 of the menu.
3. Press ► to show the options window.
4. Use ▲ or ▼ to choose Day or Night as appropriate.
5. Press the [MENU/ESC] key to close the menu.

1.18 Deep Gain

“Deep Gain” compensates for propagation attenuation of the ultrasonic waves. It does this by equalizing echo presentation so that fish schools of the same size appear in the same density in both shallow and deep waters. In addition, it reduces surface noise.

1. Press the [MENU/ESC] key to open the menu.
2. Use ▲ or ▼ to choose DEEP GAIN from page 1 of the menu.
3. Press ► to show to the options window.
4. Choose Low, Medium, or High as appropriate. High provides the greatest degree of gain reduction against short range echoes.
5. Press the [MENU/ESC] key to close the menu.

1.19 Alarms

Alarm description

The LS-6100 has six conditions which generate both audio and visual alarms: bottom alarm, normal fish alarm, bottom lock fish alarm, water temperature alarm, arrival alarm and speed alarm. (The water temperature, arrival and speed alarms require appropriate sensors.)

Bottom alarm: The bottom alarm alerts you when the bottom is within the alarm range set. To activate the bottom alarm the depth must be displayed.

Fish (normal) alarm: The fish (normal) alarm tells you when fish are within the preset alarm range.

Fish (bottom lock) alarm: The fish (bottom lock) alarm, available with the bottom-lock mode, sounds when fish are within a certain distance from the bottom. Note that the Fish (normal) alarm must be turned on to use this alarm.

Water temperature alarm: The water temperature alarm alerts when the water temperature is within (Inside alarm) the alarm range set or over the range set.

Speed alarm: The speed alarm alerts you when the speed is within (Inside alarm) or over (Outside alarm) the preset speed.

Arrival alarm: The arrival alarm alerts when you are near a waypoint by the distance set.

Activating an alarm

1. Press the [ALARM] key.
2. Press ▲ or ▼ to show page 1 or page 2 of the Alarm menu as appropriate.

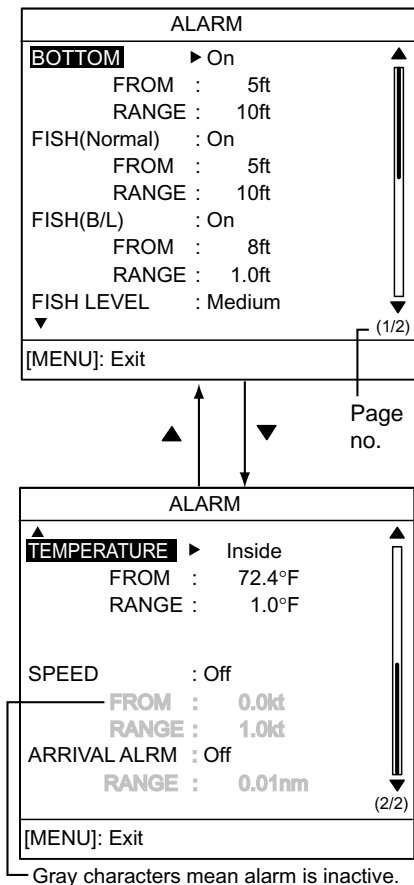

Alarm menu

- Use ▲ or ▼ to choose BOTTOM, FISH(Normal), FISH(B/L), TEMPERATURE or SPEED as appropriate.
- Press ► to show the options menu.

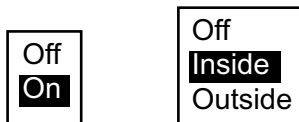

Fish, Arrival, Temp, Speed
Bottom Alarm Alarm Types
On/Off

Alarm options

- Use ▲ or ▼ to choose alarm type:
 - Off:** Alarm off
 - On:** Alarm on
 - Inside:** Alarm generated when speed (water temperature) is within the range set.
 - Outside:** Alarm generated when speed (water temperature) is outside the range set.
- Press ◀ to close the window.
- Press ▼ to choose FROM.

- Press ► to show the options menu.

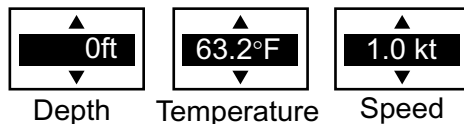

Depth Temperature Speed

Depth, temperature, speed setting window

- Use ▲ or ▼ to set starting depth, temperature or speed as appropriate.
- Press ◀ to close the window.
- Press ▼ to choose RANGE.
- Press ► to show the options menu.
- Use ▲ or ▼ to set alarm range.
- For the bottom alarm, temperature alarm, speed alarm and arrival alarm, press the [MENU/ESC] key to finish. For a fish alarm, press ◀ to close the window, and then go to step 15.**
- Press ▼ to choose FISH LEVEL.
- Press ► to show the options menu.

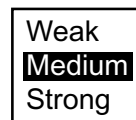

Fish level options

- Use ▲ or ▼ to choose the echo strength level which will trigger a fish alarm:
 - Weak:** Weak echoes (weakest tone on level bar)
 - Medium:** Medium strength echoes (middle tone on level bar)
 - Strong:** Strong echoes (darkest tone on level bar)
- Press the [MENU/ESC] key to close the menu.

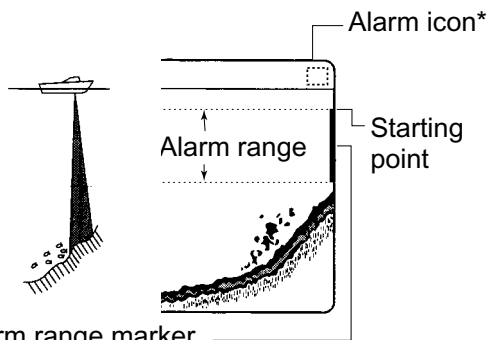

Alarm range marker

- Bottom alarm, Fish alarm (normal): Right
- Fish alarm (bottom/lock): Left

* Alarm icon

- 🔊: Bottom alarm
- 🔊: Fish alarm (normal)
- 🔊: Fish alarm (B/L)
- 🔊: Temperature alarm (°C or °F shown)
- 🔊: Speed alarm
- 🔊: Arrival alarm

How the alarm works

Note: To disable an alarm, choose Off at step 5 in the above procedure.

Silencing the buzzer

The buzzer sounds and the appropriate alarm icon appears and flashes when an alarm is violated. You can silence the buzzer by pressing the [ALARM] key. However, the buzzer will sound whenever the alarm setting is violated.

Note: The audio and visual alarms are released against the last-violated alarm when multiple alarms are active.

1.20 Resetting Trip Distance

1. Press the [MENU/ESC] key to open the menu.
2. Use ▲ or ▼ to choose TRIP RESET? from page 2 of the menu.
3. Press ►.
4. Press ▲ to reset trip distance. Beeps are generated while the trip distance is being reset.
5. Press the [MENU/ESC] key to close the menu.

Note: To reset the odometer to zero, clear the memory.

1.21 Setting the Draft

The default depth display shows the distance from the transducer. If you would rather show the distance from the sea surface, set your ship's draft as follows:

1. Press the [MENU/ESC] key to open the menu.
2. Use ▲ or ▼ to choose DRAFT from page 2 of the menu.
3. Press ► and then use ▲ or ▼ to set draft. The setting range is -15 to 50 (meters, feet).
4. Press the [MENU/ESC] key to close the menu.

1.22 Gain Compensation

If the gain is too high or too low, or the gain for the low and high frequencies appears unbalanced, you can compensate it as follows:

1. Press the [MENU/ESC] key to open the menu.
2. Use ▲ or ▼ to choose GAIN ADJ 200 or GAIN ADJ 50 from page 2 of the menu.
3. Press ► to show to the options window.
4. Use ▲ or ▼ to set the amount. The setting range is -50 to +50.
5. Press the [MENU/ESC] key to close the menu.

1.23 Setting Up Nav Data Displays

The user may arrange the nav data displays as desired.

1. Use the [MODE] key to select the nav data display you want to set up.
2. Press the Cursor Pad to display the NAV DATA SETUP window.

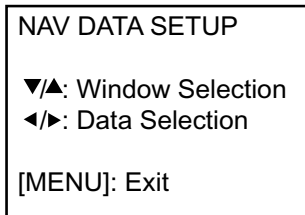

NAV DATA SETUP window

3. Use ▲ or ▼ to choose a data display window desired. A dashed-line rectangle circumscribes your selection.
4. Use ◀ or ▶ to choose item to display. See the next page for a description of the displays.

(1)	(3)	(6)
(2)	(4)	(7)
	(5)	(8)
		(9)

Two-data display

Three-data display

Four-data display

Items displayable in (1) - (3): depth, position, course, range and bearing, trip distance, odometer, water temperature, heading, air pressure, time-to-go to destination waypoint, XTE*, speed*, wind speed and direction*, destination waypoint data*, compass*

Items displayable in (4) - (9): depth, position, course, range and bearing, trip distance, odometer, water temperature, heading, air pressure, time-to-go to destination waypoint, XTE*, wind speed and direction

* = Graphic display

Nav data window and item displayable

5. Press the [MENU/ESC] key to finish.

Note: You can choose the number of items to show in a nav data display with NAV DATA-1 and NAV DATA-2 on the System menu.

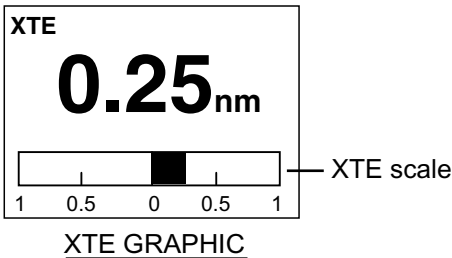
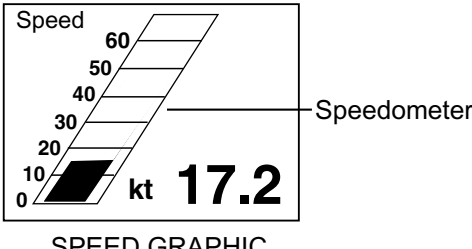
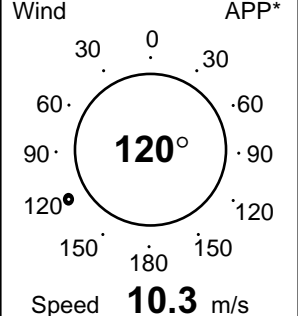
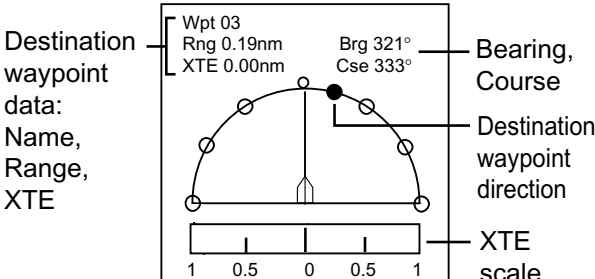
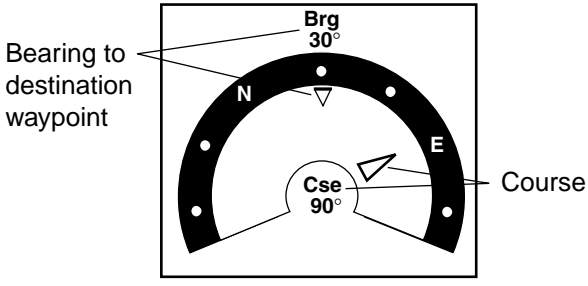
GRAPHIC DISPLAYS	DIGITAL DISPLAYS
	<div data-bbox="826 248 1077 376"> <p>Depth</p> <p>32.8ft</p> <p>DEPTH</p> </div> <div data-bbox="1114 248 1364 376"> <p>Temperature</p> <p>69.8°F</p> <p>WATER TEMPERATURE</p> </div>
	<div data-bbox="826 443 1077 571"> <p>Position</p> <p>30° 00.065'N 130° 00.574'E</p> <p>POSITION</p> </div> <div data-bbox="1114 443 1364 571"> <p>Heading TRUE/MAG#</p> <p>318°</p> <p>HEADING</p> </div>
	<div data-bbox="826 638 1077 766"> <p>Speed</p> <p>19.3kt</p> <p>SPEED</p> </div> <div data-bbox="1114 638 1364 766"> <p>Wind Speed APP*</p> <p>8.0m/s</p> <p>WIND SPEED</p> </div>
	<div data-bbox="826 824 1077 952"> <p>Course</p> <p>123.0°</p> <p>COURSE</p> </div> <div data-bbox="1114 824 1364 952"> <p>Wind Dir. APP*</p> <p>138°</p> <p>WIND DIRECTION</p> </div>
	<div data-bbox="826 1019 1077 1146"> <p>Rng Brg</p> <p>1.21nm 140°</p> <p>RANGE & BEARING&</p> </div> <div data-bbox="1114 1019 1364 1146"> <p>Air Pressure</p> <p>1018hpa</p> <p>AIR PRESSURE</p> </div>
	<div data-bbox="826 1220 1077 1348"> <p>Trip meter</p> <p>121nm</p> <p>TRIP DISTANCE</p> </div> <div data-bbox="1114 1220 1364 1348"> <p>Time to Go</p> <p>00H30M</p> <p>TIME-TO-GO&</p> </div>
	<div data-bbox="826 1422 1077 1550"> <p>Odometer</p> <p>56nm</p> <p>ODOMETER</p> </div> <p>* APP or TRUE depending on menu setting. # TRUE or MAG depending on menu setting. & To destination waypoint</p>
	<p>Note 1: Nav data is updated with some delay. Note 2: When data is lost 120 sec., the display shows "- -" at the location where data is lost.</p>

Nav data displays

2. SYSTEM & INSTALLATION MENUS

The System menu mainly consists of items which once set do not require frequent adjustment. You may display this menu by choosing SYSTEM MENU at page 2 of the menu and pressing ►.

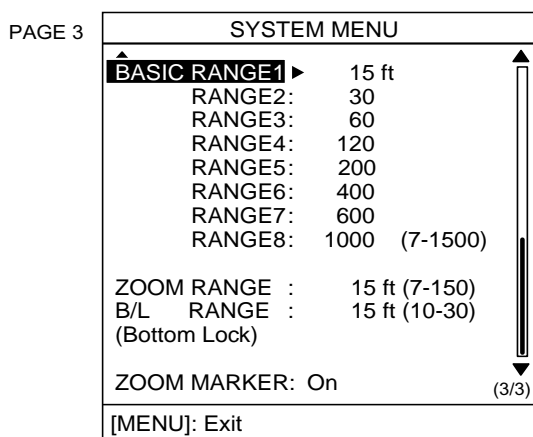
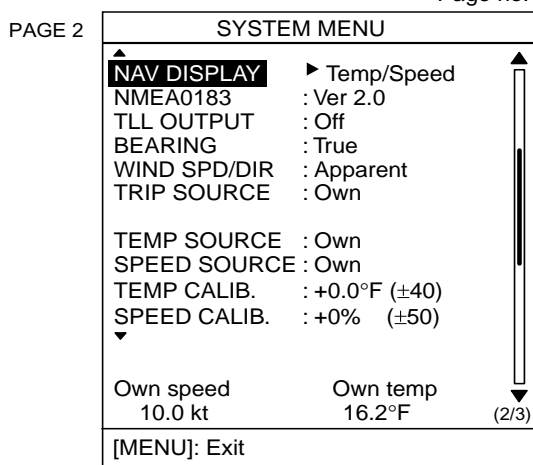
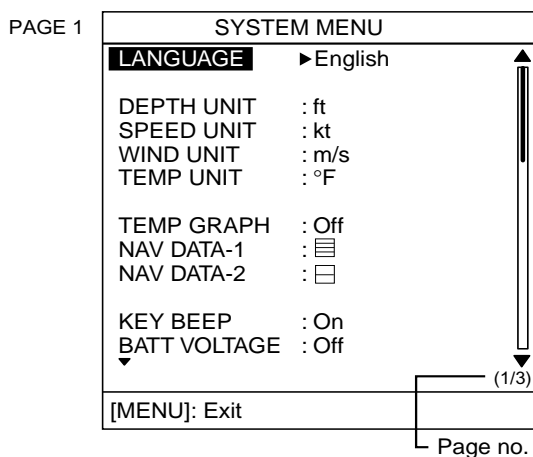

System menus

2.1 System Menu

Page 1

LANGUAGE: The system language is available in English, several European languages and Japanese. To change language, select language desired and press the [MENU/ESC] key.

DEPTH UNIT: Choose unit of depth measurement from meters, feet, fathoms, passi/braza and hiro (Japanese).

SPEED UNIT: Choose unit of speed measurement from knots, miles per hour and kilometers per hour. Requires speed data.

WIND UNIT: Choose unit of wind speed measurement from m/s, kt, km/h, and mph. Requires wind speed data.

TEMP UNIT: Choose unit of temperature measurement; Celsius or Fahrenheit. Requires temperature data.

TEMP GRAPH: Turns the water temperature display on or off. The temperature scale range is 16° (°F) in "Narrow"; 40° (°F) in "Wide". Requires water temperature data.

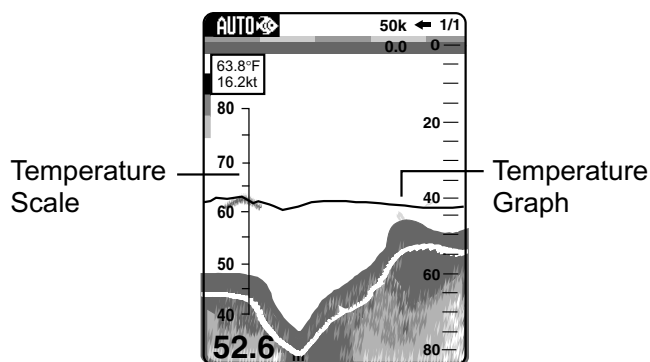

Water temperature display (wide, °F)

NAV DATA-1, -2: Choose the number of navigation data items to display on the nav data displays, from two, three or four items. Requires appropriate nav data.

KEY BEEP: Turn key beep on or off.

BATT VOLTAGE: Turn the battery voltage indication (appears at the top right corner on the screen) on or off. When on it replaces the picture advance speed indication.

Page 2

NAV DISPLAY: Choose the nav data to display in the nav data window at the top left-hand corner. You may choose from temperature/speed, latitude/longitude, range and bearing, course over ground, trip distance or wind speed. Requires appropriate nav data.

40.7°F 16.2kt

Nav window (water temperature and speed)

NMEA0183: Choose NMEA version of navigator; Ver. 1.5, Ver. 2.0 or Ver. 3.0.

TLL OUTPUT: Enables/disables output of TLL (Target Latitude, Longitude) position when the [MARK] key is operated. "TLL" outputs latitude and longitude position. "FURUNO-TLL," available with connection of navigator that can output FURUNO TLL, outputs latitude and longitude, water temperature, depth, etc.

BEARING: Ship's course and bearing to a waypoint may be displayed in true or magnetic bearing. Magnetic bearing is true bearing plus (or minus) earth's magnetic deviation. Requires bearing data.

WIND SPD/DIR: Choose the wind speed and direction reference from true and apparent. Requires wind sensor.

Apparent: The direction (in relation to ship's bow) and speed of the wind as it appears to those on board, relative to the speed and direction of the boat; combination of the true wind and the wind caused by the boat's movement.

True: The speed and direction (in relation to ship's bow) of the wind felt or measured when stationary.

TRIP SOURCE: Choose speed source for the trip distance indication; Own (transducer w/speed sensor or separate speed sensor) or NMEA.

TEMP SOURCE: Choose source of water temperature input; Off, Own (transducer w/water temperature sensor or separate temperature sensor), or NMEA.

SPEED SOURCE: Choose source of speed input; Off, Own (transducer w/speed sensor or separate speed sensor), or NMEA. Requires speed data.

TEMP CALIB.: If the water temperature sensor-generated water temperature indication is wrong, you can correct it here, when "Own" is selected as temperature source. For example, if the water temperature indication is 2° higher than actual water temperature, enter -2. The setting range is -40°F to +40°F.

SPEED CALIB.: If the speed sensor-generated speed indication is wrong, you can correct it here, when "Own" is selected as speed source. For example, if the speed indication is 10% lower than actual speed, enter +10. The setting range is -50% to +50%.

BASIC RANGE 1 - BASIC RANGE 8: Set range of each of the eight basic ranges.

Note 1: All default basic ranges are restored whenever the depth unit is changed. Therefore, change the depth unit before changing the basic ranges.

Note 2: A range may not be lower than the range preceding it. For example, if basic range 3 is 60 feet, basic range 4 must be greater than 60 feet.

ZOOM RANGE: Choose the range to zoom in the marker-zoom and bottom-zoom modes. You may choose a range between 7 and 150 feet (2 and 50 meters).

B/L RANGE: The expansion width for the bottom-lock display can be chosen from 10 to 30 feet (3 and 10 meters).

ZOOM MARKER: The zoom marker appears in the normal, bottom marker and bottom zoom displays and marks the area which is expanded in the bottom marker and bottom zoom pictures. You can turn the marker on or off as desired.

2.2 Installation Menu

The installation menu contains items which once set do not require frequent adjustment.

1. Turn on the power while pressing the [MENU/ESC] key. Continue pressing the [MENU/ESC] key until the Installation menu appears.

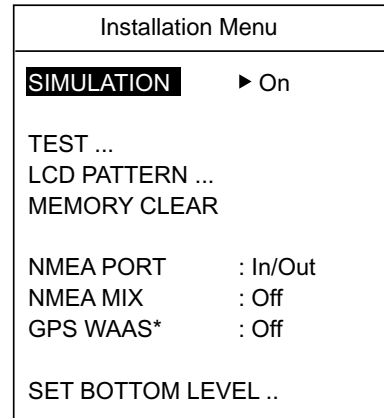

* = Setting cannot be changed when NMEA PORT setting is "IN/IN."

Installation menu

SIMULATION: The simulation mode provides, without connection of the transducer, simulated operation of the equipment, using internally generated echoes. All controls are operative. The message "SIM" appears at the top right corner on the screen when the simulation mode is active.

1. At the installation menu, press ► to open the simulation mode options window.
2. Press ▼ to choose "On" to turn on the simulation mode.
3. Press the [POWER/BRILL] key about three seconds to turn off the power.
4. Press the [POWER/BRILL] key to turn on the power. "SIM" appears at the top right corner of the display
5. To turn off the simulation mode, select Off at step 2.

TEST: Conducts diagnostic tests. For further details, see paragraph 3.7.

LCD PATTERN: Tests the LCD. For further details, see paragraph 3.8

MEMORY CLEAR: The memory can be cleared to start afresh with default menu settings.

1. At the installation menu, press ▼ to choose MEMORY CLEAR.
2. Press ► to open the options window.

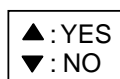

Clear memory display

4. Press ▲ to clear the memory. Beeps are generated while the memory is being cleared.
5. To restore normal operation, turn off the power and then turn it on again.

NMEA PORT: Sets the function of the NMEA port. For further details, see paragraph 4.7.

NMEA MIX: Turns data mixing on or off. For further details, see paragraph 4.7.

GPS WAAS: Chooses how to use the WAAS signal.

Note: WAAS is currently in the developmental phase. During the developmental phase the reliability and availability of the WAAS signal cannot be guaranteed. Therefore, any position data should be verified against other sources to confirm reliability.

1. Display the Installation menu.
2. Choose GPS WAAS and then press ► to open the GPS WAAS options window.

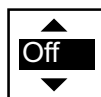

WAAS options window

3. Press ▲ or ▼ to choose “WAAS-02” (test signal). When the system becomes operational (in 2003), set to “00” (regular WAAS signal).
4. Turn off the power.

BOTTOM LEVEL: If the depth indication is unstable in automatic operation, or the bottom echo cannot be displayed in the darkest gray tone by adjusting the gain controls in manual operation, you may adjust the bottom echo level detection circuit, for both 50 kHz and 200 kHz, to stabilize the indication. Generally, lower the bottom level for inner hull installation where the receive level is too low. If the bottom level is too low it may be difficult to discriminate fish from the bottom, resulting in unstable depth indication. And if the bottom level is too high the depth indication may not appear.

1. At the installation menu, press ▼ to choose SET BOTTOM LEVEL and then press ►. Several seconds later the following display appears.

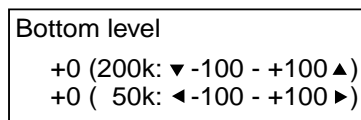

Bottom level display

2. While observing the picture, use ▲ or ▼ to set 200 kHz; ◀ or ▶ to set 50 kHz. Set up for optimum picture.
3. To restore normal operation, turn off the power and then it on again.

Note: The mode must be other than NAV DATA to show the bottom level display.

3. MAINTENANCE, TROUBLESHOOTING

⚠ WARNING

ELECTRICAL SHOCK HAZARD
Do not open the equipment.

Only qualified personnel should work inside the equipment.

3.1 Maintenance

Regular maintenance is essential for good performance. Checking the items listed in the table below monthly will help keep your equipment in good shape for years to come.

Checking

Item	Action
Transducer cable	Check cable for damage.
Power cable, transducer cable plug	Check that they are tightly fastened. Refasten if necessary.
Display unit ground	Check for corrosion. Clean if necessary.
Power supply voltage	Check voltage. If out of rating correct problem.

3.2 Cleaning the Display Unit

Dust or dirt on the display unit can be removed with a soft cloth. If desired, a water-moistened cloth may be used. Use special care when cleaning the LCD since it scratches easily. Do not use chemical cleaners to clean the display unit - they can remove paint and markings.

3.3 Transducer Maintenance

Marine life on the transducer face will result in a gradual decrease in sensitivity. Check the transducer face for cleanliness each time the boat is dry-docked. Carefully remove any marine life with a piece of wood or fine-grade sandpaper.

3.4 Replacing the Fuse

The fuse in the power cable protects the system from reverse polarity of the power supply and equipment fault. If the fuse blows, find the cause before replacing it. Use only a 1A fuse (61NM-125V, 1A, or equivalent FGBO-A, AC125V, 1A, Code No. 000-549-061). Using the wrong fuse will damage the unit and void the warranty.

⚠ WARNING



Use the proper fuse.

Fuse rating is shown on the equipment. Use of a wrong fuse can result in fire and damage the equipment.

3.5 Battery Voltage Alert

A battery icon appears when the battery voltage is too high or too low.

Battery icon and meaning

Icon	Meaning
	Voltage is lower than 10 VDC. If the voltage goes below 9 V, the equipment is automatically turned off.
	Voltage is higher than 16.5 VDC. If the voltage goes higher than 17.5 V, the equipment is automatically turned off.

3.6 Troubleshooting

The table below provides basic troubleshooting procedures which the user may follow to restore normal operation.

Troubleshooting table

If...	Then check ...
neither echo nor fixed range scale appears	<ul style="list-style-type: none"> • battery voltage. • fuse. • power supply. • power cable.
no echo appears but the fixed range scale appears	<ul style="list-style-type: none"> • if display advance speed is set to "Stop." • transducer plug
echo appears but no zero line	<ul style="list-style-type: none"> • if range shifting is set to "0."
sensitivity is low	<ul style="list-style-type: none"> • gain setting. • if air bubbles or marine life is clinging to the transducer face. • if sediments are present in the water. • if the bottom is too soft to return an echo.
there is extreme interference or noise	<ul style="list-style-type: none"> • if the transducer is too close to the engine. • if the unit is properly grounded. • if other echo sounders of the same frequency as own are being operated nearby.
the speed/water temperature readout is unrealistic or not present	<ul style="list-style-type: none"> • sensor plug.
the position readout is unrealistic or not present	<ul style="list-style-type: none"> • the connection between sounder and navigator. • navigator.

3.7 Diagnostics

If you feel your unit is not working properly, conduct the diagnostic test to find the problem. If you cannot restore normal operation, contact your dealer for advice.

1. Turn on the power while pressing the [MENU/ESC] key. Continue pressing the [MENU/ESC] key until the Installation menu appears.

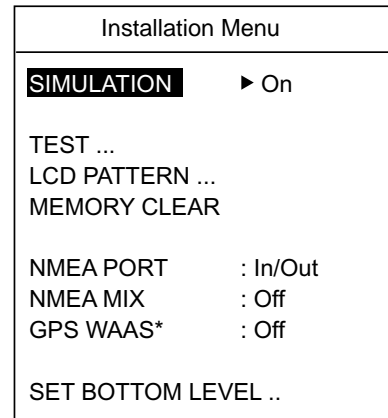

* = Setting cannot be changed when NMEA PORT setting is "In/In."

Installation menu

2. Press ▼ to choose TEST.
3. Press ▶ to start the test.

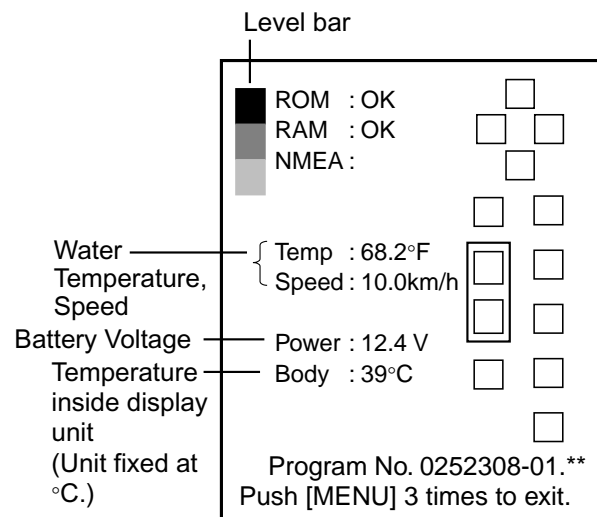

** = Program version no.

Test display

4. The ROM, RAM and NMEA port are checked, with the results shown as OK or NG (No Good). For any NG, request service. (A special connector is required to test the NMEA port. Nothing appears if no connector is connected.)
5. The squares at the right side of the test display are for checking the controls. Press each key and the arrows on the Cursor Pad one by one. A control's corresponding on-screen square "lights" in black if the control is normal.
6. To return to the Installation menu, press the [MENU/ESC] key three times.
7. To restore normal operation, turn off the power and turn it on again.

3.8 Test Pattern

This feature tests for proper display of tones.

1. Turn on the power while pressing the [MENU/ESC] key. Continue pressing the [MENU/ESC] key until the Installation menu appears.
2. Press ▼ to choose LCD PATTERN.
3. Press ► to start the test. The entire screen is black.
4. Press ► again and the screen turns white.
5. Press ► again and the screen shows a four-toned display.
6. Press ► again to return to the Installation menu.
7. To restore normal operation, turn off the power and then it on again.

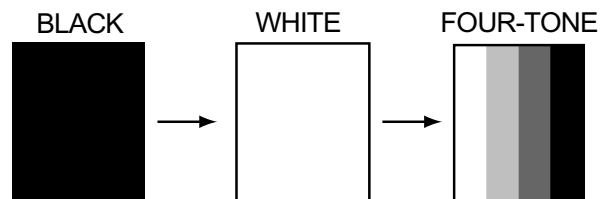

Test patterns

4. INSTALLATION

4.1 Display Unit

Mounting considerations

The display unit can be installed on a desktop, on the overhead or flush mounted in a panel. When choosing a mounting location keep the following in mind:

- Keep the display unit out of direct sunlight.
- The temperature and humidity should be moderate and stable.
- Locate the unit away from exhaust pipes and vents.
- The mounting location should be well ventilated.
- Mount the unit where shock and vibration are minimal.
- Keep the unit away from electromagnetic field-generating equipment such as motors and generators.
- For maintenance and checking purposes, leave sufficient space at the sides and rear of the unit and leave slack in cables.
- A magnetic compass will be affected if placed too close to the display unit. Observe the following compass safe distances to prevent disturbance to the magnetic compass:

Standard compass: 0.5 meters

Steering compass: 0.35 meters

Desktop, overhead mounting

1. Fix the bracket to a desktop or the overhead with tapping screws (supplied).
2. Loosely screw knobs into the display unit.
3. Set the display unit to the bracket and then tighten the knobs.

Flush mounting in a panel

See the instructions on the flush mounting template (supplied).

4.2 Thru-hull Mount Transducer

Transducer mounting location

The thru-hull mount transducer (520-5PSD, 520-5MSD) provides the best performance of all, since the transducer protrudes from the hull and the effect of air bubbles and turbulence near the hull skin is reduced. When the boat has a keel, the transducer should be at least 30 cm away from it. Typical thru-hull mountings are shown in the figure on the next page.

The performance of this sounder is directly related to the mounting location of the transducer, especially for high-speed cruising. The installation should be planned in advance, keeping the standard cable length (8 m) and the following factors in mind:

- Air bubbles and turbulence caused by movement of the boat seriously degrade the sounding capability of the transducer. The transducer should, therefore, be located in a position where water flow is the smoothest. Noise from the propellers also adversely affects performance and the transducer should not be mounted nearby. The lifting strakes are notorious for creating acoustic noise, and these must be avoided by keeping the transducer inboard of them.
- The transducer must always remain submerged, even when the boat is rolling, pitching or up on a plane at high speed.

- A practical choice would be somewhere between 1/3 and 1/2 of the boat's length from the stern. For planing hulls, a practical location is generally rather far astern, so that the transducer is always in water regardless of the planing attitude.

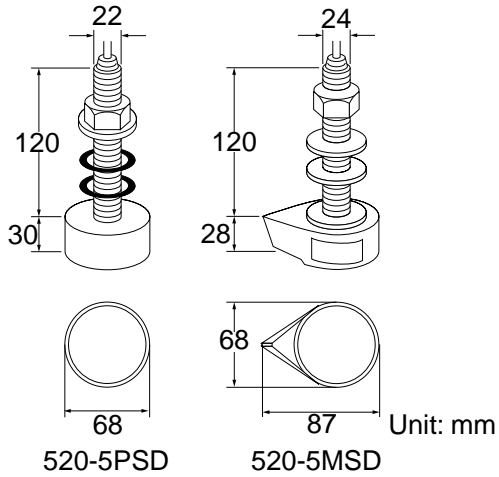

520-5PSD 520-5MSD
Thru-hull mount transducer mounting dimensions (millimeters)

Acceptable transducer mounting locations

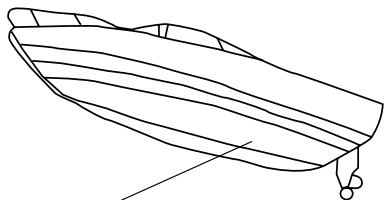

- Position 1/2 to 1/3 of the hull from stern.
- 15 to 30 cm off center line (inside first lifting strakes.)

HIGH SPEED-V HULL

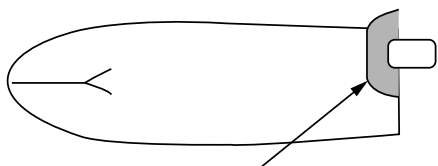
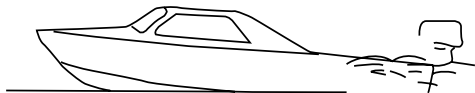

- Within the wetted bottom area
- Deadrise angle within 15°

Suitable transducer mounting locations

Typical thru-hull mount transducer installations

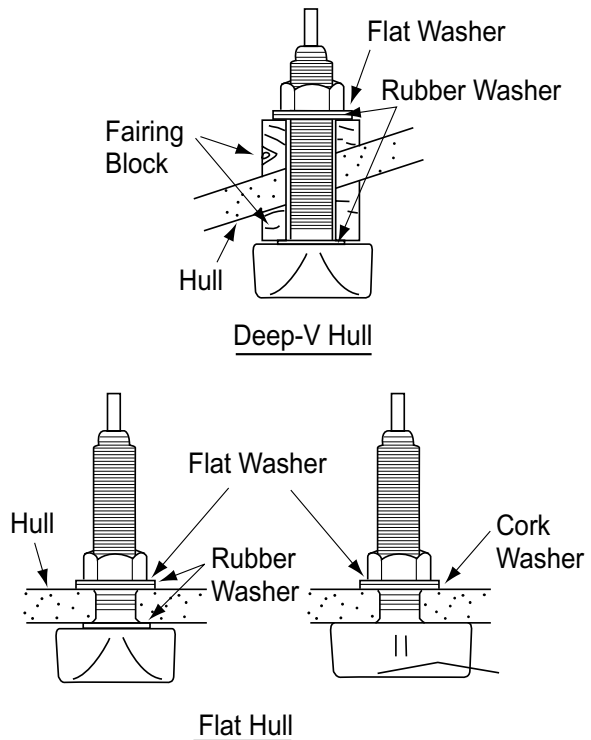

Typical thru-hull mount transducer installations

Procedure for installing the thru-hull mount transducer

1. With the boat hauled out of the water, mark the location chosen for mounting the transducer on the bottom of the hull.
2. If the hull is not level within 15° in any direction, fairing blocks made out of teak should be used between the transducer and hull, both inside and outside, to keep the transducer face parallel with the water line. Fabricate the fairing block as shown below and make the entire surface as smooth as possible to provide an undisturbed flow of water around the transducer. The fairing block should be smaller than the transducer itself to provide a channel to divert turbulent water around the sides of the transducer rather than over its face.

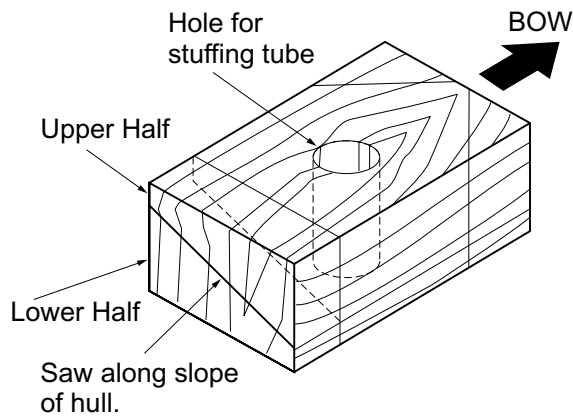

Construction of fairing block

3. Drill a hole just large enough to pass the threaded stuffing tube of the transducer through the hull, making sure it is drilled vertically.
4. Apply a sufficient amount of high quality caulking compound to the top surface of the transducer, around the threads of the stuffing tube and inside the mounting hole (and fairing blocks if used) to ensure watertight mounting.
5. Mount the transducer and fairing blocks and tighten the locking nuts. Be sure that the transducer is properly oriented and its working face is parallel to the waterline.

Note: Do not over-stress the stuffing tube and locking nuts through excessive tightening, since the wood block will swell when the boat is placed in the water. It is suggested that the nut be tightened lightly at installation and retightened several days after the boat has been launched.

4.3 Transom Mount Transducer

The transom mount transducer (520-5PWD) is very commonly employed, usually on relatively small I/O or outboard boats. Do not use this method on an inboard motor boat because turbulence is created by the propeller ahead of the transducer.

There are two methods of installation: flush with hull (for flat hulls) and projecting from hull (for deep V-hulls).

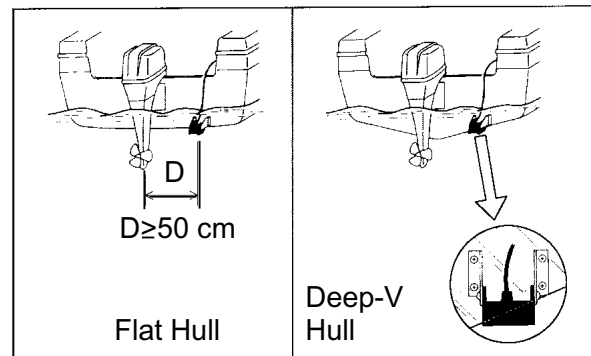

Transom mount transducer mounting locations

Installing the transom mount transducer on a flat hull

A suitable mounting location is at least 50 cm away from the engine and where the water flow is smooth.

1. Drill four pilot holes in the mounting location.
2. Attach the transducer to the bracket with 5 x 20 tapping screws (supplied).
3. Adjust the transducer position so the transducer faces right to the bottom.

Note: If necessary, to improve water flow and minimize air bubbles staying on the transducer face, incline the transducer about 5° at the rear. This may require a certain amount of experimentation for fine tuning at high cruising speeds.

4. Fill the gap between the wedge front of the transducer and transom with epoxy material to eliminate any air spaces.

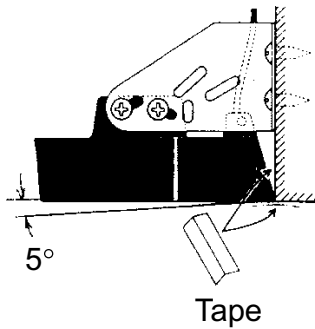
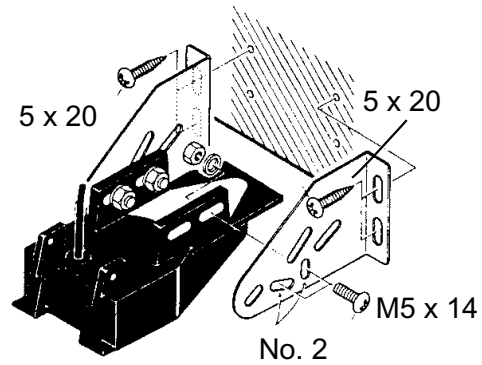
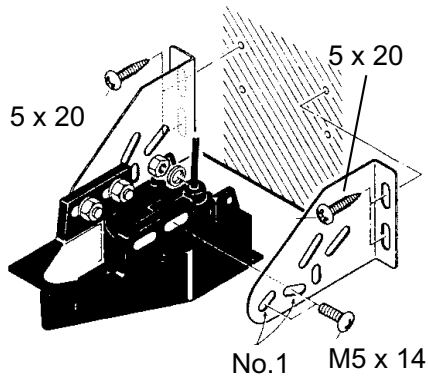

*Transom mount transducer,
mounting flush with hull*

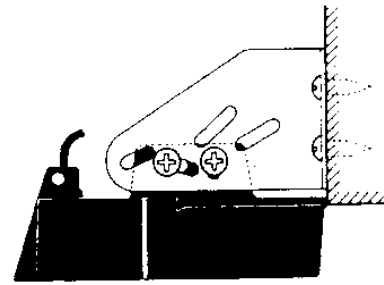

*Transom mount transducer,
mounted projecting from hull*

Installing the transom mount transducer on a deep-V hull

This method is employed on deep-V hulls and provides good performance because the effects of air bubbles are minimal. Install the transducer parallel with water surface; not flush with hull. If the boat is placed on a trailer care must be taken not to damage the transducer when the boat is hauled out of the water and put on the trailer.

Transducer preparation

Before putting the boat in water, wipe the face of the transducer thoroughly with a detergent liquid soap. This will lessen the time necessary for the transducer to have good contact with the water. Otherwise the time required for complete "saturation" will be lengthened and performance will be reduced.

DO NOT paint the transducer. Performance will be affected.

4.4 Inside-hull Transducer

The thru-hull mount transducer (520-5PSD, 520-5MSD) may also be installed inside the hull, following the procedure below.

Necessary tools

You will need the following tools:

- Sandpaper (#100)
- Silicone sealant
- Silicone grease

Remarks on installation

- Turn off the engine and anchor the boat while installing the equipment.
- Install the transducer in the engine room.

Choosing the mounting location

- Keep the following points in mind when choosing a mounting location:
- The mounting location should be where the hull is of single-hull thickness and is void of air or flotation materials other than solid fiberglass between the transducer face and the water.
- Do not place the transducer over hull struts or ribs which run under the hull.
- Avoid a location where the rising angle of the hull exceeds 15° , to minimize the effect of the boat's rolling.
- You will finalize the mounting location through some trial and error. The procedure for this is shown later.

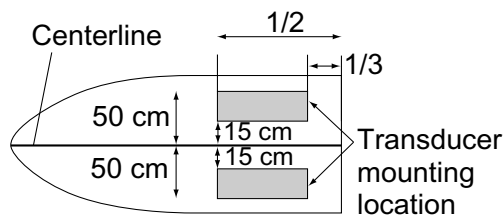

Inside-hull transducer mounting location

Attaching the transducer

1. Clean the transducer face to remove any foreign material. Lightly roughen the transducer face with #100 sandpaper. Also, roughen the inside of the hull where the transducer is to be mounted.
2. Warm the silicone sealant to 40°C before usage to soften it. Coat the transducer face and mounting location with silicone sealant.

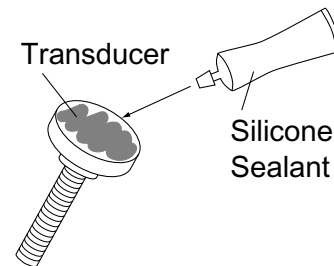

Coating transducer face with silicone sealant

3. Press the transducer firmly down on the hull and gently twist it back and forth to remove any air which may be trapped in the silicone sealant.

Checking the installation

1. Connect the battery to the display unit.
2. Turn on the display unit.
3. Press the [MODE] key to choose SINGLE FREQ.
4. Choose 50 kHz or 200 kHz, and then press the [MENU/ESC] key to close the mode menu.
5. Press the [PROG] key to show the pop-up window for automatic/manual selection.
6. Press \blacktriangle to choose Manual.
7. Press the [MENU/ESC] key..
8. Press the [GAIN] key to set the gain to "5" and then press the [MENU/ESC] key.
9. Press the [RANGE] key to set the range to 10 meters (feet) and then press the [MENU/ESC] key.

10. If the bottom is displayed in dark gray and the depth indication appears, the mounting location is suitable. Go to "Final preparation."
11. If the bottom is not displayed in dark gray tone, the mounting location may be unsuitable. Do the following:
 - a) Press the [POWER/BRILL] key to turn off the power.
 - b) Gently dismount the transducer with a piece of wood.
 - c) Reattach the transducer elsewhere as shown in "Attaching the transducer."
 - d) Check the installation again.

Final preparation

Support the transducer with a piece of wood to keep it in place while it is drying. Let the transducer dry 24-72 hours.

4.5 Optional Triducer

525ST-MSD

The optional triducer 525ST-MSD is designed for thru-hull mounting. For how to install this transducer see paragraph 4.2.

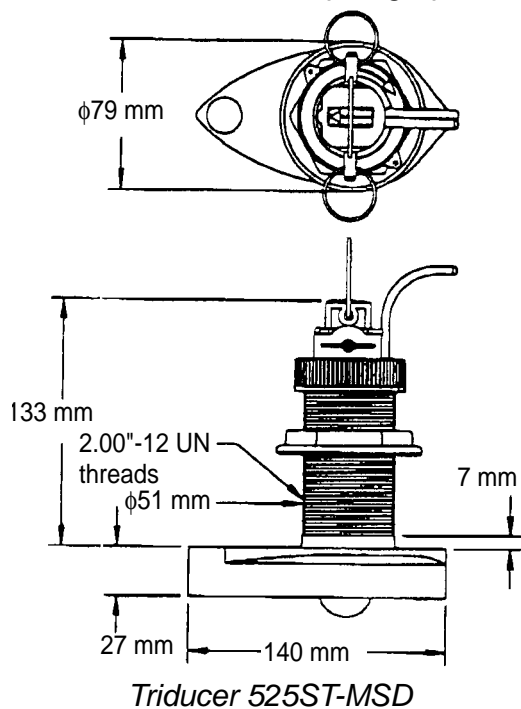

525ST-PWD

The Transom Mount Transducer or TRIDUCER® Multisensor with Integral Release Bracket 525ST-PWD is manufactured by AIRMAR Co. These instructions are included with the sensor.

Pre-test for speed and temperature

Connect the sensor to the instrument and spin the paddlewheel. Check for a speed reading and the approximate air temperature. If there is no reading, return the sensor to your place of purchase.

Tools and materials needed

- Scissors
- Masking tape
- Safety goggles
- Dust mask
- Electric drill
- Drill bit for:
 - Bracket holes: 4mm, #23, or 9/64"
 - Fiberglass hull: chamfer bit (preferred), 6mm, or 1/4"
 - Transom hole: 19mm or 3/4" (optional)
 - Cable clamp holes: 3mm or 1/8"
- Screwdrivers
- Straight edge
- Marine sealant
- Pencil
- Zip-ties
- Water-based antifouling paint (**mandatory in salt water**).

Mounting location

To ensure the best performance, the sensor must be submerged in aeration-free and turbulence-free water. Mount the sensor close to the centerline of the boat. On slower heavier displacement hulls, positioning it farther from the centerline is acceptable.

Allow adequate space above the bracket for it to release and rotate the sensor upward.

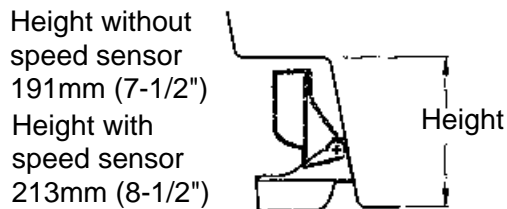

Height required at mounting location

Note 1: Do not mount the sensor in an area of turbulence or bubbles: near water intake or discharge openings; behind strakes, struts, fittings, or hull irregularities; behind eroding paint (an indication of turbulence).

Note 2: Avoid mounting the sensor where the boat may be supported during trailering, launching, hauling, and storage.

Note 3: For single drive boat, mount on the starboard side at least 75 mm (3") beyond the swing radius of the propeller.

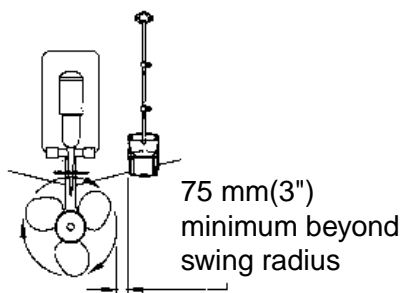

Mounting location on single drive boat

Note 4: For twin drive boat, mount between the drives.

Installation of bracket

1. Cut out the installation template shown on the left.
2. At the selected location, position the template, so the arrow at the bottom is aligned with the bottom edge of the transom. Being sure the template is parallel to the waterline, tape it in place.

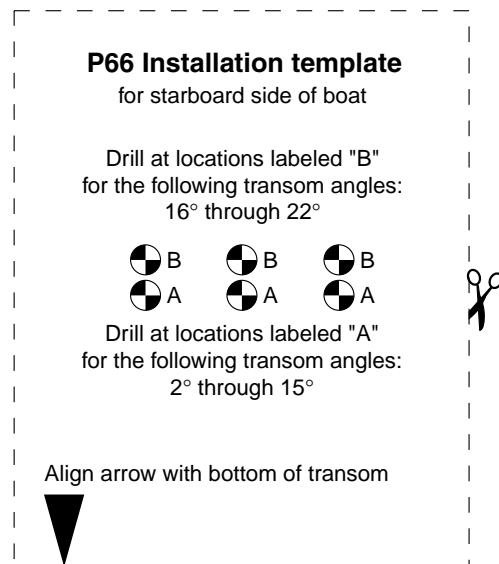

Align template vertically.

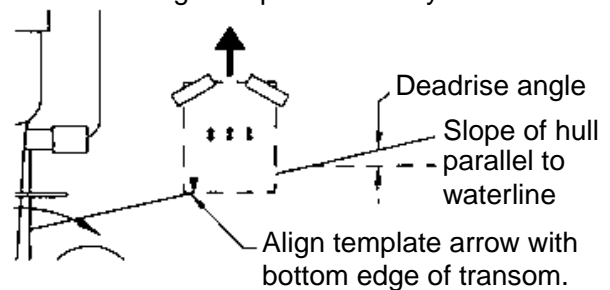

Positioning the template

Warning: Always wear safety goggles and a dust mask.

3. Using a 4 mm, #23, or 9/64" bit, drill three holes 22 mm (7/8") deep at the locations indicated. To prevent drilling too deeply, wrap masking tape around the bit 22 mm (7/8") from the point.

Fiberglass hull: Minimize surface cracking by chamfering the gelcoat. If a chamfer bit or countersink bit is not available, start drilling with a 6mm or 1/4" bit to a depth of 1 mm (1/16").

4. If you know your transom angle, the bracket is designed for a standard 13° transom angle.
11°-18° angle: No shim is required. Skip to step 3 in "Adjusting".
Other angles: The shim is required. Skip to step 2 of "Adjusting".

If you do not know the transom angle, temporarily attach the bracket and sensor to the transom to determine if the plastic shim is needed.

- Using the two #10 x 1-1/4" self-tapping screws, temporarily screw the bracket to the hull. DO NOT tighten the screws completely at this time. Follow the step 1-4 in "Attaching the Sensor to the Bracket", before proceeding with "Adjusting".

Adjusting

- Using a straight edge, sight the underside of the sensor relative to the underside of the hull. The stern of the sensor should be 1-3 mm (1/16-1/8") below the bow of the sensor or parallel to the bottom of the hull.

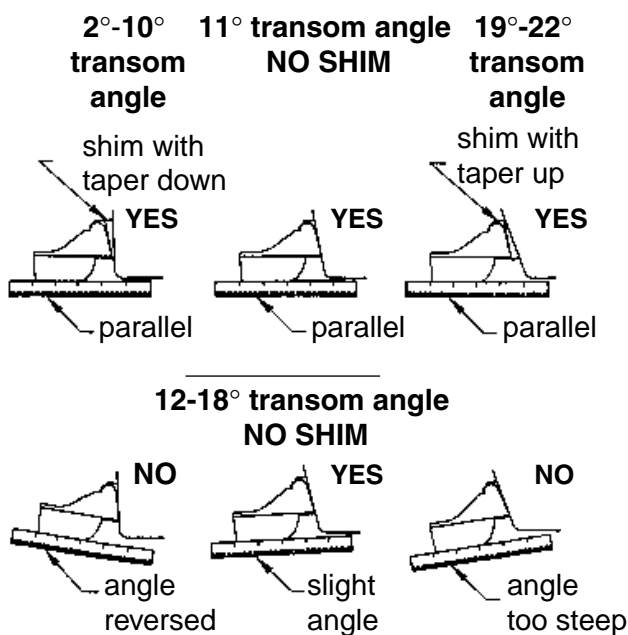

Sensor position and transom angle

Note: Do not position the bow of the sensor lower than the stern because aeration will occur.

- To adjust the sensor's angle relative to the hull, use the tapered plastic shim provided. If the bracket has been temporarily fastened to the transom, remove it, Key the shim in place on the back of the bracket.

2°-10° transom angle (stepped transom and jet boats): Position the shim with the tapered end down.

19°-22° transom angle (small aluminum and fiberglass boats): Position the shim with the tapered end up.

- If the bracket has been temporarily fastened to the transom, remove it. Apply a marine sealant to the threads of the two #10 x 1-1/4" self tapping screws to prevent water seeping into the transom. Screw the bracket to the hull. Do not tighten the screws completely at this time.
- Repeat step 1 to ensure that the angle of the sensor is correct.

Note: Do not position the sensor farther into the water than necessary to avoid increasing drag, spray, and water noise and reducing boat speed.

- Using the vertical adjustment space on the bracket slots, slide the sensor up or down to provide a projection of 3 mm (1/8"). Tighten the screws.

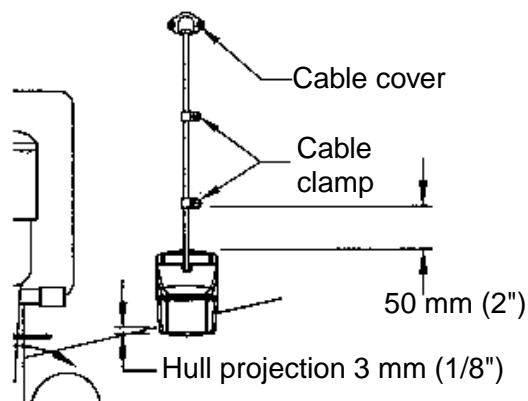

Vertical adjustment and cable routing

Attaching the sensor to the bracket

1. If the retaining cover near the top of the bracket is closed, open it by depressing the latch and rotating the cover downward.

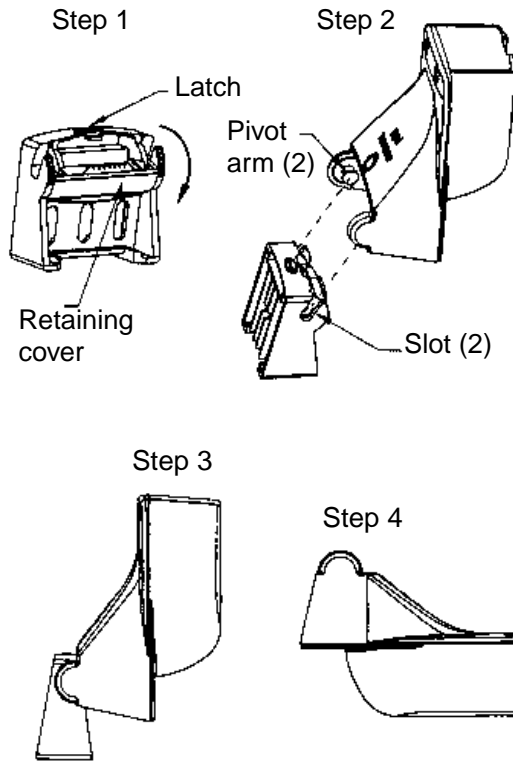

Attaching the sensor to the bracket

2. Insert the sensor's pivot arms into the slots near the top of the bracket.
3. Maintain pressure until the pivot arms click into place.
4. Rotate the sensor downward until the bottom snaps into the bracket.
5. Close the retaining cover to prevent the accidental release of the sensor when the boat is underway.

Cable routing

Route the sensor cable over the transom, through a drain hole, or through a new hole drilled in the transom above the waterline.

Never cut the cable or remote the connector; this will void the warranty. Always wear safety goggles and a dust mask.

1. If a hole must be drilled, choose a location well above the waterline. Check for obstructions such as trim tabs, pumps, or wiring inside the hull. Mark the location with a pencil. Drill a hole through the transom using a 19 mm or 3/4" bit (to accommodate the connector).
2. Route the cable over or through the transom.
3. On the outside of the hull secure the cable against the transom using the cable clamps. Position a cable clamp 50 mm (2") above the bracket and mark the mounting hole with a pencil.
4. Position the second cable clamp halfway between the first clamp and the cable hole. Mark this mounting hole.
5. If a hole has been drilled in the transom, open the appropriate slot in the transom cable cover. Position the cover over the cable where it enters the hull. Mark the two mounting holes.
6. At each of the marked locations, use a 3 mm or 1/8" bit to drill a hole 10 mm (3/8") deep. The prevent drilling too deeply, wrap masking tape around the bit 10 mm (3/8") from the point.
7. Apply marine sealant to the threads of the #6 x 1/2" self-tapping screw to prevent water from seeping into the transom. If you have drilled a hole through the transom, apply marine sealant to the space around the cable where it passes through the transom.
8. Position the two cable clamps and fasten them in place. If used, push the cable cover over the cable and screw it in place.
9. Route the cable to the instrument being careful not to tear the cable jacket when passing it through the bulkhead(s) and other parts of the boat. To reduce electrical interference, separate the sensor cable from other electrical wiring and "noise" sources. Coil any excess cable and secure it in place with zip-ties to prevent damage.

4.6 Optional Water Temperature/Speed Sensor

Water temperature/speed sensor ST-02MSB and ST-02PSB, which are designed for thru-hull mounting, are optionally available. Install them as shown below.

Mounting considerations

Choose a suitable mounting location considering the following:

- Choose a place free from vibration.
- Choose a mid-boat flat position. The sensor does not have to be installed perfectly perpendicular. The sensor must not be damaged in dry-docking operation.
- Choose a place apart from equipment generating heat.
- Choose a place in the forward direction viewing from the drain hole, to allow for circulation of cooling water.

1. Dry-dock the boat.
2. Make a hole of approx. 51 mm diameter in the mounting location.
3. Unfasten locknut and remove the sensor section.
4. Apply high-grade sealant to the flange of the sensor.
5. Pass the sensor casing through the hole.
6. Face the notch on the sensor toward boat's bow and tighten the flange.
7. Set the sensor section to the sensor casing and tighten the locknut.
8. Launch the boat and check for water leakage around the sensor.

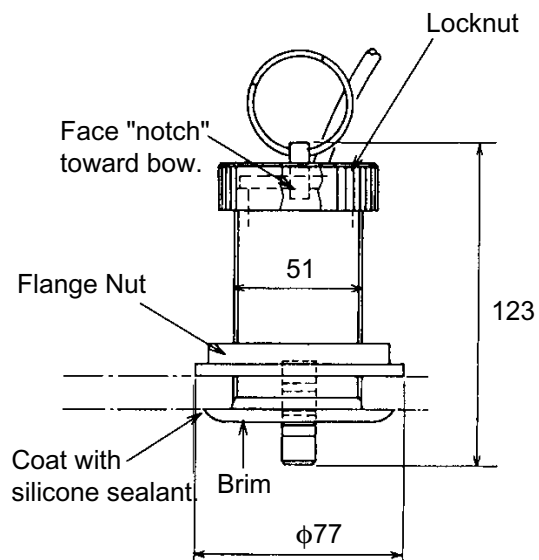

*Water temperature/speed sensor
ST-02MSB, ST-02PSB*

4.7 Wiring

Refer to the interconnection diagram to connect cables. Leave slack in cables to facilitate checking and maintenance.

Establishing the ground

The ground wire (1.25sq or more, local supply) should be as short as possible. The ground for the signal line is isolated from the chassis, however the power line is not insulated. Therefore, to connect external equipment whose positive polarity is connected to the ground line, do not connect the signal line ground to chassis ground.

The signal line ground is isolated from the chassis ground, however the power line is not insulated. Therefore, when connecting external equipment having positive ground, do not ground the signal line to the chassis.

If excessive noise shows on the screen, the ground may be inadequate. In this case, attach a steel plate measuring 20 cm by 30 cm on the outside of the hull to provide a ground point. Connect the ground wire there. Use a "closed" type lug () to make the connection at the display unit. Do

not use an “open” type lug ()

Optional equipment

Pin arrangement on NMEA port

Connector		Remarks
1	TD-A	IEC-61162-1/NMEA0183
2	TD-B	
3	RD-A	IEC-61162-1/NMEA0183
4	RD-B	
5	+Vout	Power output max. 100 mA*
6	GND	
7	FG	

* = The LS-6100 can feed 12 V power to GP-310B, GP-320B. The power voltage must be at least 12 V to feed power to those units.

NMEA port setup

The NMEA port can function as an input port or input/output port. Change the setting to “In/In” when connecting GP-310B and a wind sensor.

When connecting the GP-320B and a wind sensor, first turn on “GPS WAAS” (in the Installation menu) and then select “In/In” as the NMEA port setting.

1. Turn on the power while pressing and holding down the [MENU/ESC] key. Continue pressing the [MENU/ESC] key until the Installation menu appears.
2. Choose NMEA PORT, and then press ► to display the NMEA port options window.
3. Use ▲ or ▼ to choose In/Out or In/In as appropriate.

In/Out: Input and Output (default setting)

In/In: Input only (Available with connection of the GP-310B and a wind sensor.)

4. Press ◀, choose NMEA MIX, and then press ► to display the NMEA MIX options window.

5. Use ▲ or ▼ to choose Off or On. Choose On to output input data.
6. To restore normal operation, turn off the power and then turn it on again.

Water temp/speed sensor

Connect the optional water temp/speed sensor to the XDR connector with the optional converter connector (Type 02S4147) as shown below.

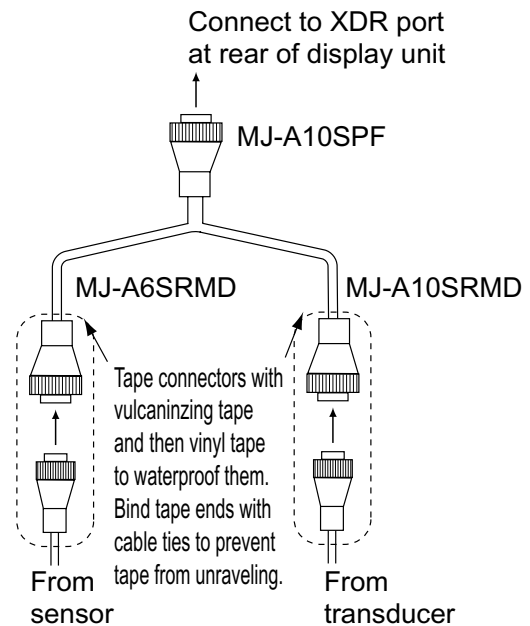

Connection of converter connector 02S4147

GP-320B

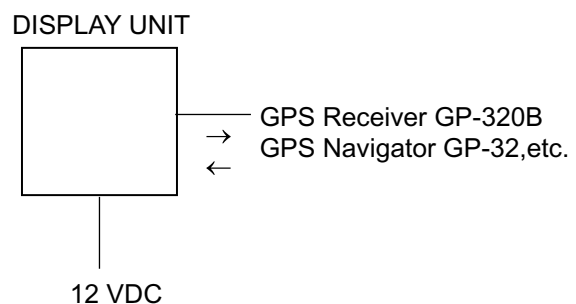

NMEA port setting: IN/OUT

Connection of GP-320B

Wind sensor

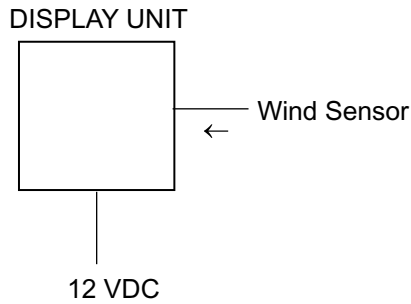

NMEA port setting: IN/OUT

Connection of wind sensor

Feeding data to RD-30 via the LS-6100

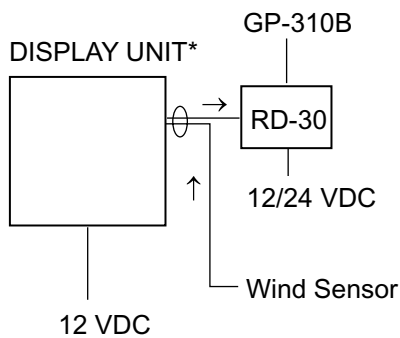

NMEA port setting: IN/OUT
NMEA mix setting: ON

*: Navigator-related data not displayed.

4.8 IEC 61162-1 Data Sentences

The tables below show the data sentences which can be input to and output from the LS-6100. The transmission speed for both input and output is 4800 bps. Data is output at two-second intervals.

Input data sentences

Sentence	Meaning
BWC	Bearing and distance to waypoint
GGA	Global positioning system (GPS) fix data
GLL	Geographic position - latitude/longitude
HDG	Heading, deviation and variation
HDT	Heading, true
MDA	Atmospheric pressure
MTW	Water temperature

Input data sentences (con't)

Sentence	Meaning
MWV	Wind speed and angle
RMA	Recommended minimum specific LORAN-C data
RMB	Recommended minimum navigation information
RMC	Recommended minimum specific GPS/TRANSIT data
VHW	Water speed and heading
VTG	Course over ground and ground speed

Output data sentences

Sentence	Meaning
DBT (Ver. 1.5)	Depth below transducer
DPT (Ver. 2.0, Ver. 3.0)	Depth
MTW*	Water temperature
RMB* (Ver. 2.0)	Recommended minimum navigation information
VHW*	Water speed and heading
TLL*	Target position, output by [MARK] key.

* = Available with connection optional sensors/navaid

SPECIFICATIONS OF THE ECHO SOUNDER LS-6100

1. GENERAL

- 1.1 TX Frequency 50 kHz or 200 kHz, 50/200 kHz dual transmitting selectable
- 1.2 Transmit Method Single or dual transmitting
- 1.3 Output Power 300 Wrms
- 1.4 TX Rate Max. 550 pulse/min
- 1.5 Pulse-length 0.1 to 1.0 ms
- 1.6 Sensitivity 10 dB μ V

2. DISPLAY UNIT

- 2.1 Display system 6-inch monochrome LCD, 92 mm (W) x 122 mm (H), 240 x 320 dots
- 2.2 Display Mode Single frequency (high/low freq.), Dual-frequency, Zoom, Nav data-1/2
Marker zoom, Bottom zoom, Bottom-lock

2.3 Display Range

Range	Range Setting								Display range
	1	2	3	4	5	6	7	8	
Meter	5	10	20	40	80	150	200	300	2-500
Feet	15	30	60	120	200	400	600	1000	7-1500
Fathoms	3	5	10	20	40	80	100	150	1-250
Passi/Braza	3	5	10	30	50	100	150	200	1-300

- 2.4 Range Shift 0-500 m, 0-1500 ft, 0-250 fa, 0-300 p/b
- 2.5 Expansion Range Bottom-lock expansion: 3 to 10 m
Sectional expansion: 2 to 50 m
- 2.6 Display Advance Speed 8 steps (Lines/TX; Freeze, 1/16, 1/8, 1/4, 1/2, 1/1, 2/1, 4/1)
- 2.7 Function Settings Noise limit, Clutter, Signal level, Shift, A-scope, Deep gain
Automatic bottom tracking, White line, Hue, Advance speed

3. INTERFACE

- 3.1 Input data sentences IEC61162-1/NMEA0183 Ver 1.5/2.0/3.0
GGA, RMA, RMB, RMC, BWC, GLL, HDT, HDG, VTG, VHW, MTW,
MWV, MDA, XTE
- 3.2 Output data sentences IEC61162-1/NMEA0183 Ver 1.5/2.0/3.0, interval: 2 s
MTW*, VHW*, DBT, DPT, RMB*, TLL* by key operating
*: External data required

- 4. POWER SUPPLY 12 VDC: 0.8 A

5. ENVIRONMENTAL CONDITION

- 5.1 Ambient Temperature Display unit: -15°C to +55°C
- 5.2 Damp Heat 93% or less at 40°C
- 5.3 Water proofing IPX5

- 6. COATING COLOR N3.0

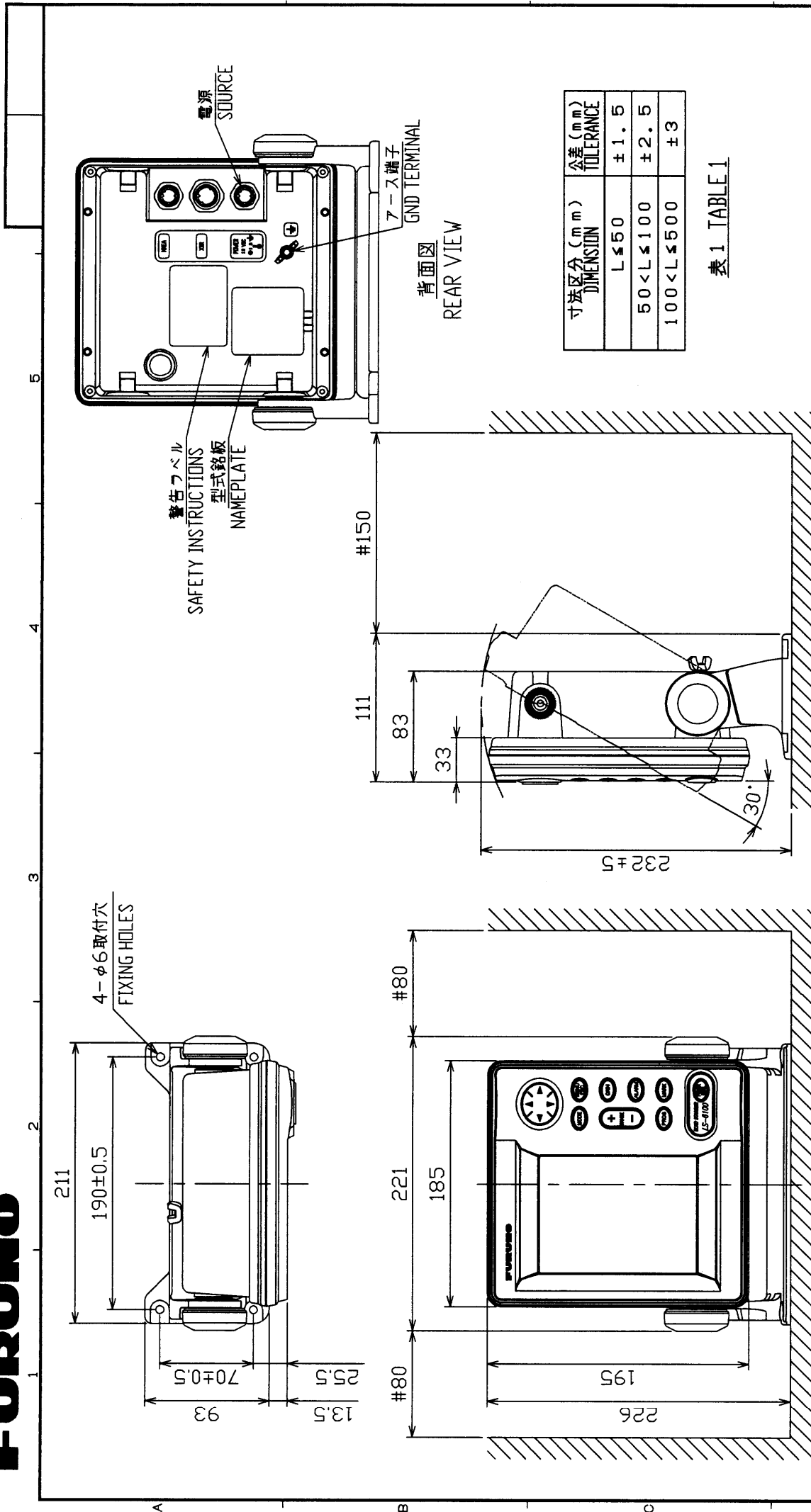

注 記 1) #印寸法は最小サービスクリアランスとする。
 2) 指定外の寸法公差は表 1 による。
 3) 取付用ネジはトラスタップピンゲネジ呼び径 5 × 2.0 を使用のこと。

NOTE 1. # INDICATES SERVICE CLEARANCE.
 2. TABLE 1 INDICATES TOLERANCE OF DIMENSIONS.
 3. USE TAPPING SCREWS 5x2.0 FOR FIXING THE UNIT.

DRAWN Feb. 6 '02	I. YAMASAKI	TITLE	LS-6100
CHECKED Feb. 6 '02	Y. K. I.	名称	指示部 (卓上装備)
APPROVED Feb. 6 '02	Y. K. I.	外寸図	
SCALE 1/4	MASS L. 3 ± 0.4	NAME	DISPLAY UNIT (DESKTOP MOUNT)
DWG. No.	C2369-G01-B		OUTLINE DRAWING
			02-139-100G-2

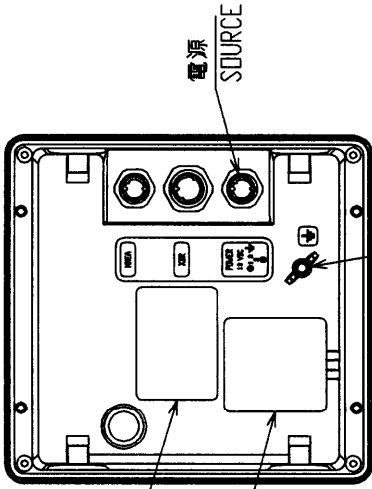

警告ラベル
SAFETY INSTRUCTIONS

型式銘板
NAMEPLATE

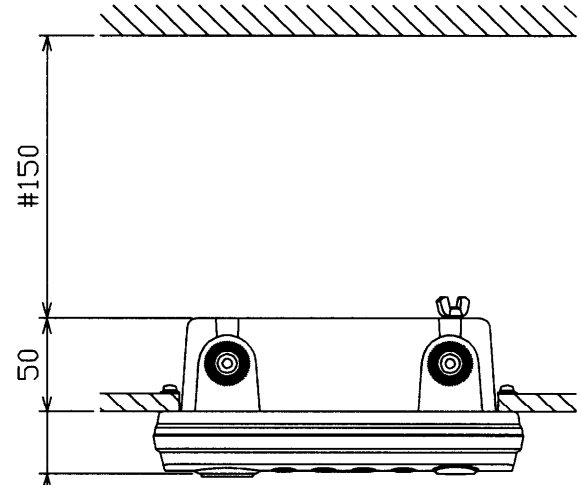
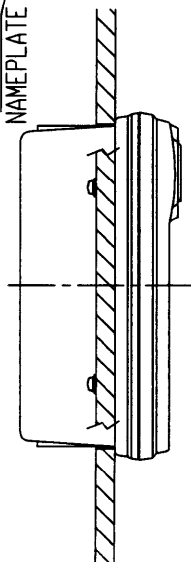

- 注記
- 1) #印寸法は最小サービス空間寸法とする。
 - 2) 指定外の寸法公差は表1による。
 - 3) 取付用ネジは、セムスネジB M4×20を使用のこと。
壁の厚さ(A)は11≦A≦14。これ以外の壁に装着する場合、
ネジ長さは(A+7.8)±2とする。
筐体にはネジ部を8mm以上入れないこと。(B部)
- NOTE
1. # RECOMMENDED SERVICE CLEARANCE.
 2. TABLE 1 INDICATES TOLERANCE OF DIMENSIONS.
 3. USE SEMS SCREWS M4×20 FOR FIXING THE UNIT.
THICKNESS A: 11≦A≦14 OR SCREW LENGTH: (A+7.8)±1.5.
DO NOT FASTEN SCREWS INTO UNIT MORE THAN 8 mm. (B≦8)

寸法区分 (mm) DIMENSION	公差 (mm) TOLERANCE
L ≦ 50	±1.5
50 < L ≦ 100	±2.5
100 < L ≦ 500	±3

表1 TABLE 1

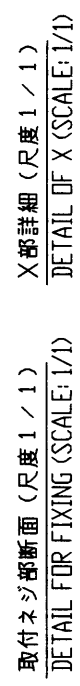
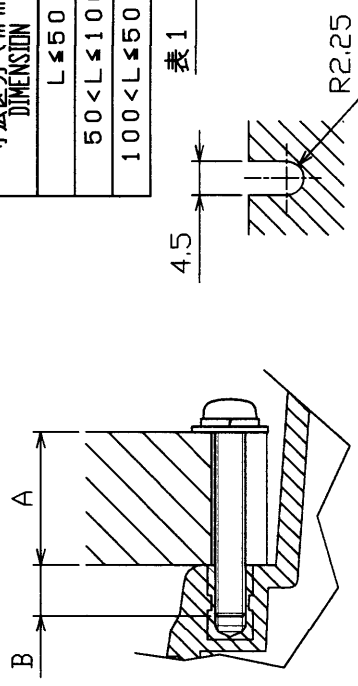

取付穴寸法図
CUTOUT DIMENSIONS

DRAWN Feb. 6 '02 I. YAMASAKI	TITLE LS-6100
CHECKED Feb. 6 '02 Y. KIKUCHI	名称 指示部 (埋込装備)
APPROVED Feb. 6 '02 Y. KIKUCHI	外寸図
SCALE 1/4	NAME DISPLAY UNIT (FLUSH MOUNT)
DWG. No. C2369-G02-B	OUTLINE DRAWING

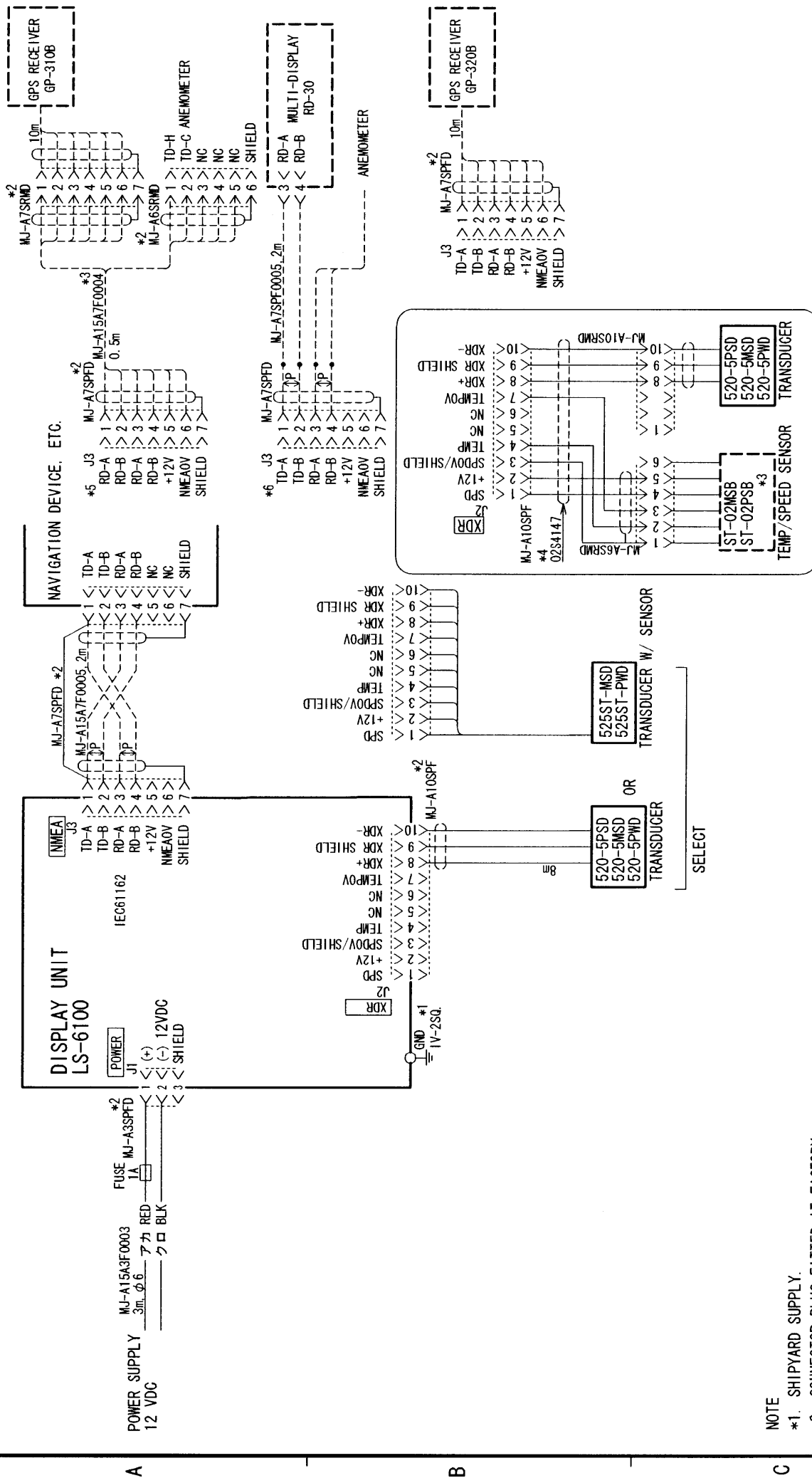

DRAWN June 14 '02 I. YAMASAKI CHECKED APPROVED DWG No E2369-001-E	TITLE LS-6100 NAME ECHO SOUNDER INTERCONNECTION DIAGRAM REMARK
---	---

- NOTE**
- *1. SHIPYARD SUPPLY.
 - *2. CONNECTOR PLUG FITTED AT FACTORY.
 - *3. OPTION.
 - *4. THREE-WAY CONVERSION CABLE NEEDED (OPTION).
 - *5. WHEN BOTH GPS RECEIVER AND ANEMOMETER ARE CONNECTED, SELECT "In/In" AT NMEA PORT IN THE INSTALLATION MENU.
 - *6. SELECT "On" AT NMEA MIX MODE IN THE INSTALLATION MENU.