

FURUNO

OPERATOR'S MANUAL

COLOR GPS/PLOTTER

MODEL GP-7000



FURUNO ELECTRIC CO., LTD.
NISHINOMIYA, JAPAN



(Elemental Chlorine Free)

The paper used in this manual
is elemental chlorine free.

© **FURUNO ELECTRIC CO., LTD.**

9-52 Ashihara-cho,
Nishinomiya 662-8580, JAPAN

Telephone : 0798-65-2111

Fax : 0798-65-4200

Your Local Agent/Dealer

All rights reserved.

Printed in Japan

Pub. No. OME-44290

(TATA) GP-7000

FIRST EDITION :AUG. 2004

B :MAY. 10, 2005



* 0 0 0 1 4 9 1 3 4 0 1 *



* O M E 4 4 2 9 0 B 0 0 *

IMPORTANT NOTICE

- No part of this manual may be copied or reproduced without written permission.
- If this manual is lost or worn, contact your dealer.
- The contents of this manual and equipment specifications are subject to change without notice.
- The example screens (or illustrations) shown in this manual may not match the screens you see on your display. The screen you see depends on your system configuration and equipment settings.
- This manual is intended for use by native speakers of English.
- FURUNO will assume no responsibility for the damage caused by improper use or modification of the equipment or claims of loss of profit by a third party.



SAFETY INSTRUCTIONS

WARNING

 **Do not open the equipment.**

Hazardous voltage which can cause electrical shock, burn or serious injury exists inside the equipment. Only qualified personnel should work inside the equipment.

Do not disassemble or modify the equipment.

Fire, electrical shock or serious injury can result.

Immediately turn off the power at the switchboard if the equipment is emitting smoke or fire.

Continued use of the equipment can cause electrical shock.

Do not operate the equipment with wet hands.

Electrical shock can result.

Use the proper fuse.

Fuse rating is shown on the power cable. Use of a wrong fuse can result in damage to the equipment.

Do not maneuver the vessel based on the depth indication alone.

Grounding may result.

CAUTION

Do not use the equipment for other than its intended purpose.

No one navigation device should ever be solely relied upon for the navigation of a vessel.

Always confirm position against all available aids to navigation, for safety of vessel and crew.

About the TFT LCD

The TFT LCD is constructed using the latest LCD techniques, and displays 99.99% of its pixels. The remaining 0.01% of the pixels may drop out or blink, however this is not an indication of malfunction.

A warning label is attached to the equipment. Do not remove the label. If the label is missing or illegible, contact a FURUNO agent or dealer.

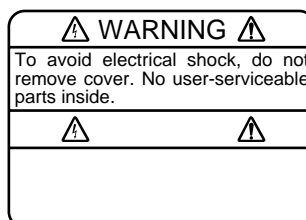

Name: Warning Label (1)
Type: 86-003-1011-1
Code No.: 100-236-231

FOREWORD

Congratulations on your choice of the FURUNO GP-7000 COLOR GPS/PLOTTER. We are confident you will see why the FURUNO name has become synonymous with quality and reliability.

For over 50 years FURUNO Electric Company has enjoyed an enviable reputation for innovative and dependable marine electronics equipment. This dedication to excellence is furthered by our extensive global network of agents and dealers.

This equipment is designed and constructed to meet the rigorous demands of the marine environment. However, no machine can perform its intended function unless installed, operated and maintained properly. Please carefully read and follow the recommended procedures for operation and maintenance.

Features

The GP-7000 provides a totally integrated GPS receiver and color video plotter.

The GPS receiver tracks up to 13 satellites (GPS: 12, WAAS: 1) simultaneously, and an 8-state Kalman filter ensures optimum accuracy in determination of vessel position, course and speed.

- C-MAP NT+ and MAX chart card (SD) is available.
- Comprehensive navigation data displays.
- Bright 7-inch color TFT LCD with brilliance control.
- Automatic coastline chart loading.
- Position display in latitude and longitude, Loran C TD.
- Alarms: Arrival, Anchor Watch, Cross-track Error, Speed, Grounding, Depth, Temperature.
- Man overboard feature records latitude and longitude coordinates at the time of man overboard.
- “Highway” display provides graphic presentation of ship’s track and is useful for monitoring cross track error.

TABLE OF CONTENTS

FOREWORD	iii
SYSTEM CONFIGURATION.....	vi
1. OPERATIONAL OVERVIEW	1-1
1.1 Display Unit Controls	1-1
1.2 Loading an SD™ Chart Card	1-2
1.3 Turning the Power On/Off	1-3
1.4 Adjusting Brilliance and Contrast	1-4
1.5 Selecting a Display	1-5
1.6 Soft Keys	1-5
1.7 MOB Mark	1-6
1.7.1 Entering the MOB mark, setting MOB as destination	1-6
1.7.2 Deleting the MOB mark	1-7
1.8 Menu Operation	1-7
1.9 Simulation Mode.....	1-9
2. PLOTTER DISPLAYS	2-1
2.1 Presentation Modes.....	2-1
2.1.1 North-up	2-1
2.1.2 Course-up	2-2
2.1.3 Auto course-up	2-2
2.2 Cursor	2-3
2.2.1 Turning on the cursor, shifting the cursor	2-3
2.2.2 Moving the cursor to the center of the screen	2-3
2.2.3 Displaying data	2-4
2.3 Selecting Chart Scale/Range.....	2-4
2.4 Navigation Data Display	2-5
2.5 Compass Display.....	2-6
2.6 Highway Display	2-7
2.7 GPS Status Display	2-8
2.8 Tide Display.....	2-9
2.9 Graph Display.....	2-10
2.10 Wind Display.....	2-11
2.11 NAVDATA Window	2-12
3. TRACK.....	3-1
3.1 Selecting Active Track.....	3-1
3.2 Displaying Track	3-2
3.3 Changing Track Color.....	3-2
3.4 Stopping, Restarting Plotting.....	3-2
3.5 Hiding the Track.....	3-3
3.6 Track Plotting Method and Interval.....	3-3
3.6.1 Track plotting method	3-3
3.6.2 Track plotting interval.....	3-4

3.7 Erasing Track	3-4
4. WAYPOINT	4-1
4.1 Entering Waypoints	4-1
4.1.1 Entering a waypoint at own ship position or cursor position.....	4-1
4.1.2 Entering a waypoint from the waypoint list	4-3
4.1.3 Entering a waypoint/MOB mark with an external event switch.....	4-4
4.2 Editing Waypoint Data.....	4-5
4.2.1 Editing waypoint data from the waypoint list.....	4-5
4.2.2 Editing a waypoint from the plotter display	4-5
4.3 Erasing Waypoints	4-6
4.3.1 Erasing a waypoint directly from the plotter display.....	4-6
4.3.2 Erasing a waypoint from the way point list.....	4-6
4.4 Searching, Sorting Waypoints	4-7
4.5 Other Waypoint List Functions	4-8
4.5.1 Filtering waypoints by mark shape	4-8
4.5.2 Hiding or showing waypoints.....	4-9
4.5.3 Searching waypoints.....	4-9
5. ROUTE	5-1
5.1 Entering Routes	5-1
5.2 Changing the Route Name.....	5-2
5.3 Connecting Routes.....	5-3
5.4 Inserting Waypoints.....	5-4
5.5 Removing Waypoints from a Route	5-5
5.6 Information on Route Report	5-6
5.7 Changing the Color of Route Line	5-7
5.8 Searching Routes	5-8
5.9 Reversing the Waypoints Order in a Route	5-8
5.10 Erasing Routes	5-8
6. NAVIGATION.....	6-1
6.1 Navigating to Quick Points	6-1
6.2 Navigating to Waypoints.....	6-4
6.3 Following a Route	6-5
6.4 Cancelling Navigation	6-6
7. ALARMS.....	7-1
7.1 Audible Alarm On/Off.....	7-2
7.2 Arrival Alarm.....	7-2
7.3 XTE (Cross-Track Error) Alarm	7-3
7.4 Temperature Alarm.....	7-4
7.5 Anchor Alarm.....	7-5
7.6 STW Alarm.....	7-5
7.7 Depth Alarm	7-6
7.8 Grounding Alarm.....	7-7
8. CUSTOMIZING YOUR UNIT	8-1
8.1 GENERAL Menu	8-1
8.2 MAP Menu	8-2

8.3 ADVANCED Menu	8-7
8.4 INFO Menu.....	8-9
8.5 FIND Menu	8-9
9. DATA TRANSFER.....	9-1
9.1 Memory Card Operations	9-1
9.1.1 Selecting the card slot to use.....	9-1
9.1.2 Formatting memory cards.....	9-2
9.1.3 Saving data to a memory card.....	9-2
9.1.4 Playing back data from a memory card.....	9-3
9.2 Uploading/Downloading Data	9-3
9.2.1 Uploading/downloading waypoints data.....	9-3
9.2.2 Uploading/downloading routes data.....	9-5
9.3 Waypoint, Route Format.....	9-6
10. MAINTENANCE & TROUBLESHOOTING.....	10-1
10.1 Maintenance	10-1
10.2 Replacement of Fuse.....	10-2
10.3 Replacing of Battery	10-2
10.4 Simple Troubleshooting	10-3
10.5 Diagnostics.....	10-5
10.5.1 RAM menu	10-4
10.5.2 Dim menu.....	10-5
10.5.3 Cartridge	10-5
10.5.4 Serial ports	10-6
10.6 Program No.	10-6
10.7 Clearing the Memory.....	10-7
10.7 GPS Cold Start	10-7
APPENDIX	AP-1
SPECIFICATIONS.....	SP-1

Notice for SDTM Card

We confirmed that the following brands of SD™ cards can be used for uploading/downloading data. For SD™ cards other than listed below, we have not yet confirmed if they are compatible with GP-7000/F.

- Kingstone
- Viking
- EP Memory
- SANDISK
- Panasonic
- Toshiba
- PQI
- Power Quotient
- ADTEC
- buffalo
- Hagiwara Sys-com
- LEXAR
- I/O DATA

SYSTEM CONFIGURATION

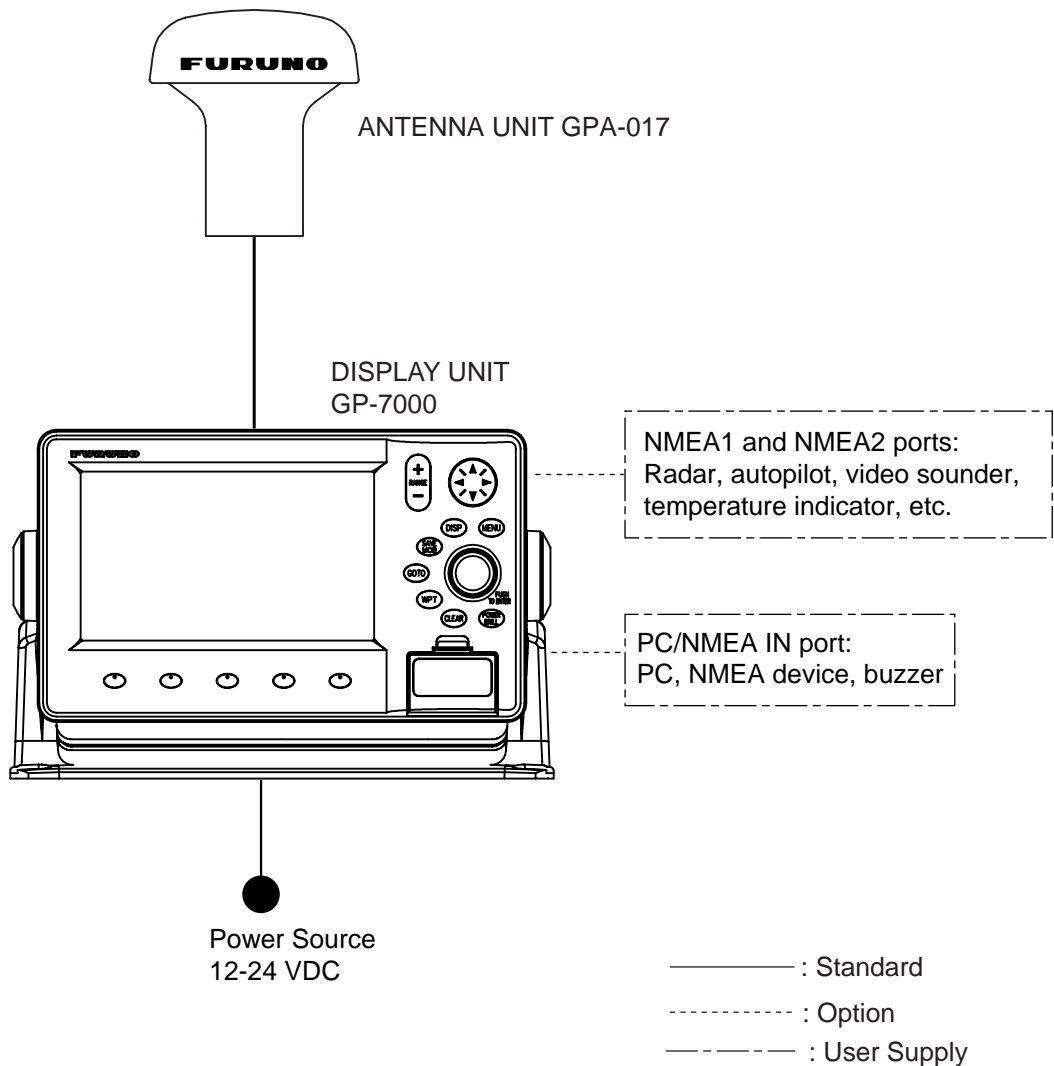

How to remove the hard cover
 Place your thumbs at the center of the cover, and then lift the cover while pressing it with your thumbs.

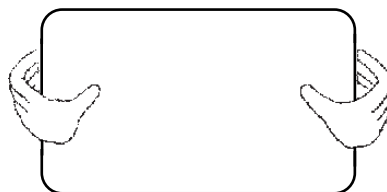

This GPS receiver complies with Canadian standard RSS-210 (Low Power License-Exempt Radio communication Devices).
 Operation is subject to the following two conditions:
 (1) this device may not cause interference, and
 (2) this device must accept any interference, including interference that may cause undesired operation of the device.

This page is intentionally blank.

1. OPERATIONAL OVERVIEW

This chapter acquaints you with the basics of your unit—from turning on the power to the soft key menu operation.

1.1 Display Unit Controls

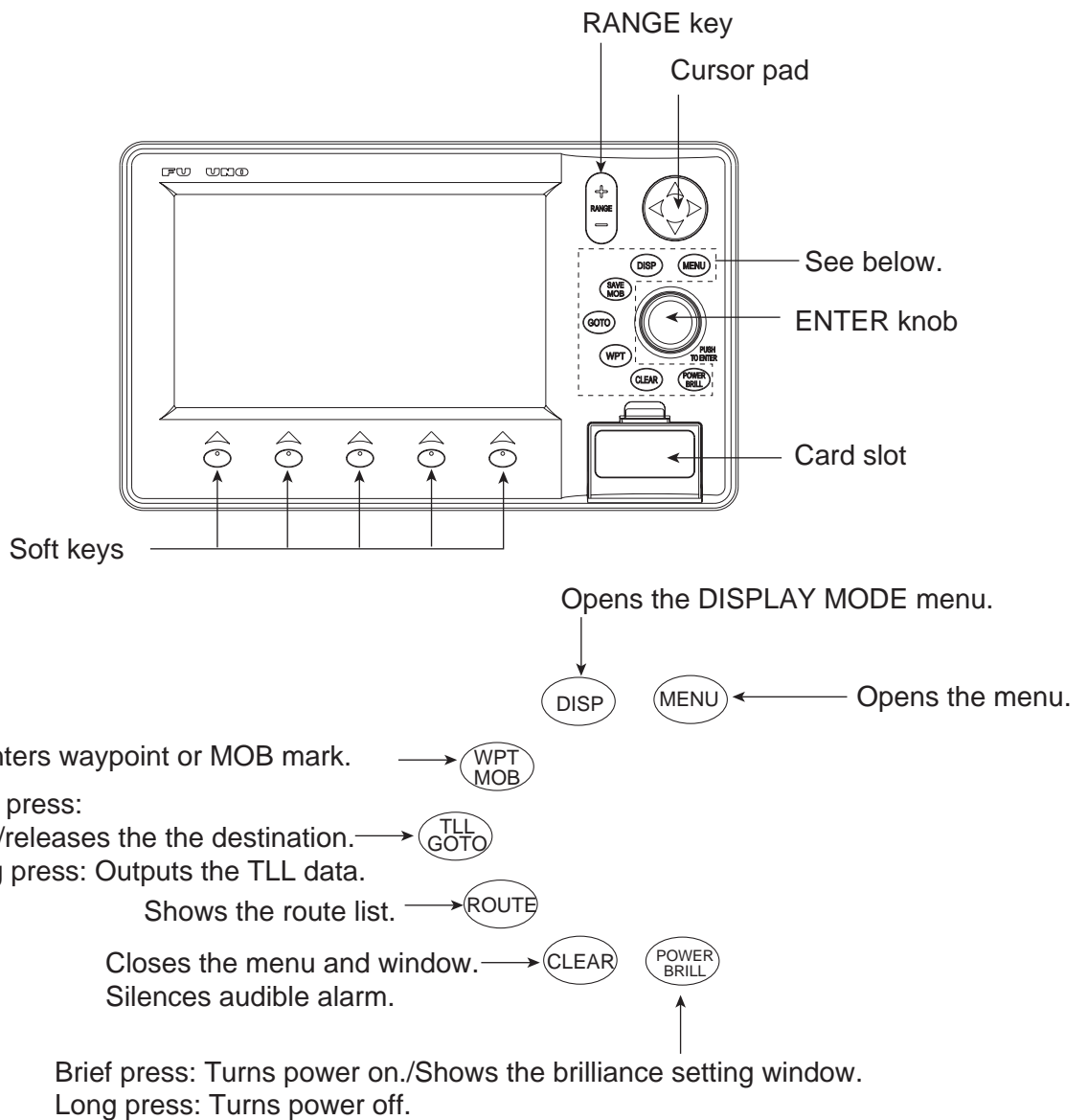

Display unit, front view

1.2 Loading an SD™ Chart Card

Your unit reads C-MAP NT+ /NT MAX™ charts, stored on SD™ cards. Insert the appropriate chart card for your area before turning the power on to show chart data automatically.

Note 1: Static electricity can be passed through your fingers to a card and destroy the contents of the card. To prevent this, always touch a metallic object, such as a steel desk, before handling an SD™ card.

Note 2: Do not insert or remove a card while the power is on. This may cause the equipment to freeze.

1. Push down the lid catch to open the card slot cover.

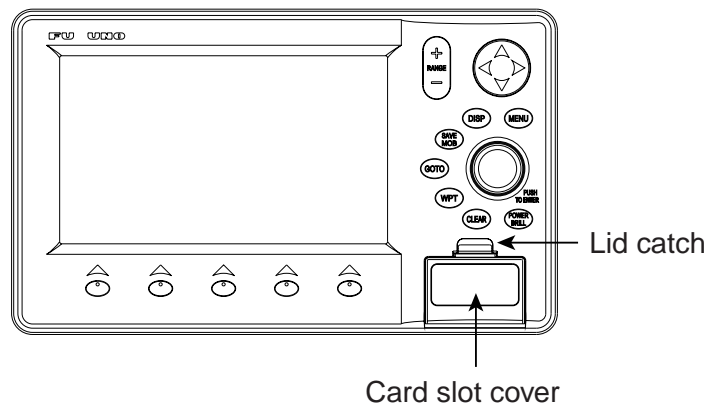

Card slot cover

2. Insert appropriate SD™ chart card label side up to any slot.

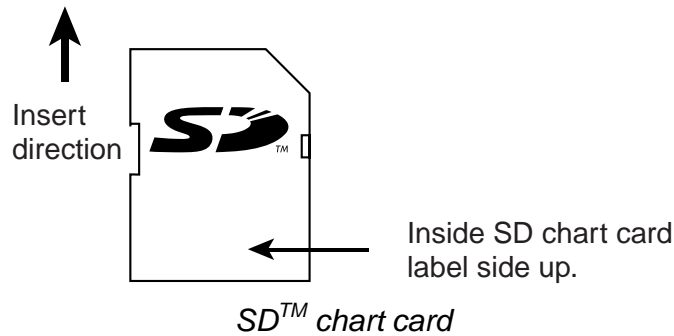

3. Press the center of the lid catch to close the card slot cover, to protect the chart drive. (Keep the slot cover closed at all times.)

1.3 Turning the Power On/Off

Turning the power on

Press the [POWER/BRILL] key until you hear a click and a beep. When the unit is turned on, it proceeds in the sequence shown in the figure below.

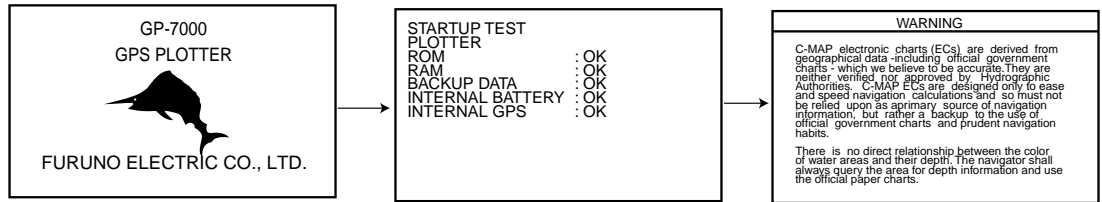

In about 30 seconds the last-used display appears. You can go to the last-used display faster by pressing any key when this screen appears.

Start-up sequence

- Note 1:** The example screens shown in this manual may not match the screens you see on your display. The screen you see depends on your system configuration and equipment settings.
- Note 2:** If the message “SYSTEM HAS FAILED START UP TEST. PLEASE CONTACT A LOCAL FURUNO REPRESENTATIVE FOR REPAIR. PRESS ANY KEY TO CONTINUE.” appears, contact your dealer for advice.
- Note 3:** At the very first time you turn on your unit, the simulation mode window appears. Choose YES or NO as appropriate and push the [ENTER] knob.

The equipment takes 90 seconds to find its position when turned on for the very first time. Thereafter it takes about 12 seconds to find position each time the power is turned on. The message “NO FIX”, which means the equipment is now finding its position, appears at the bottom of the plotter display immediately after turning the power on. When the GPS receiver finds its position, “NO FIX” changes to “2D” or “3D” to show that position data is now accurate.

Turning the power off

Press and hold the [POWER/BRILL] key until the screen goes blank (about four seconds).

1.4 Adjusting Brilliance and Contrast

You can adjust display brilliance and contrast as shown below.

1. Press the [POWER/BRILL] key momentarily.
The BACKLIGHT window appears.

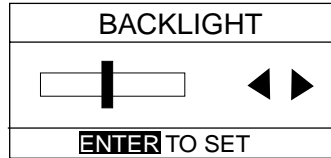

Backlight window

2. Rotate the [ENTER] knob to adjust.
Rotate clockwise to raise the setting or counterclockwise to decrease it.
To escape from this window without adjusting, press the [CLEAR] or [POWER/BRILL] key, or wait three seconds to let the equipment close it automatically.
3. Press the [ENTER] key to close the window.

1.5 Selecting a Display

Nine screen displays are available as shown figure in below.

1. Press the [DISP] key to show the DISPLAY MODE screen.

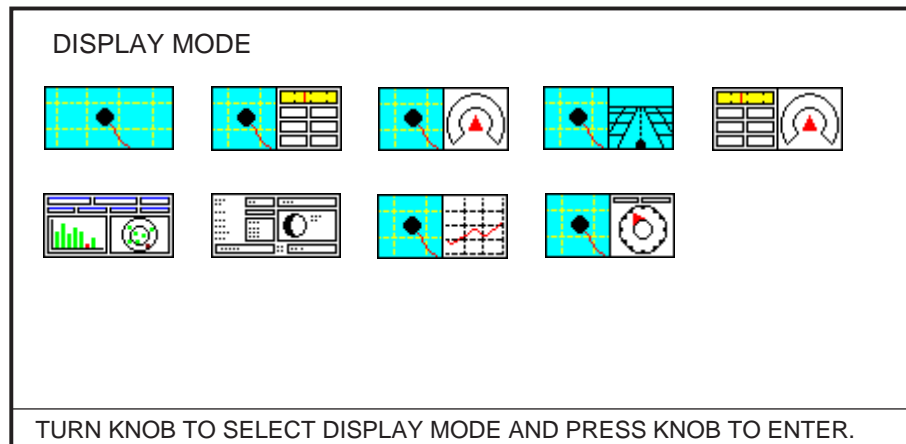

Display mode screen

2. Use the cursor pad or [ENTER] knob to select a mode.
To escape from the display mode screen without changing the display mode, press the [DISP] key.
3. Press the [ENTER] knob to set the new display mode.

1.6 Soft Keys

The soft keys, their labels displayed at the bottom of the screen, provide for one-touch execution of a desired function, and their label and function change according to the display in use. When you turn on the power, the soft keys do not appear. To show the soft keys, press any soft key. To access a soft key function, press the appropriate soft key within five seconds after accessing them.

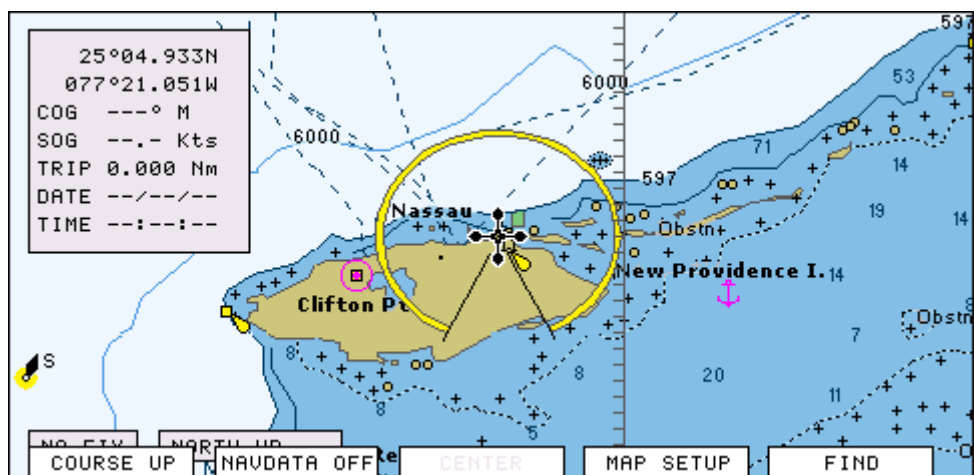

Soft keys

The soft keys disappear after five seconds. If you want to erase them earlier, press the [CLEAR] key.

1.7 MOB Mark

1.7.1 Entering the MOB mark, setting MOB as destination

The MOB (Man Overboard) mark functions to mark man overboard position. You can inscribe this mark from any mode.

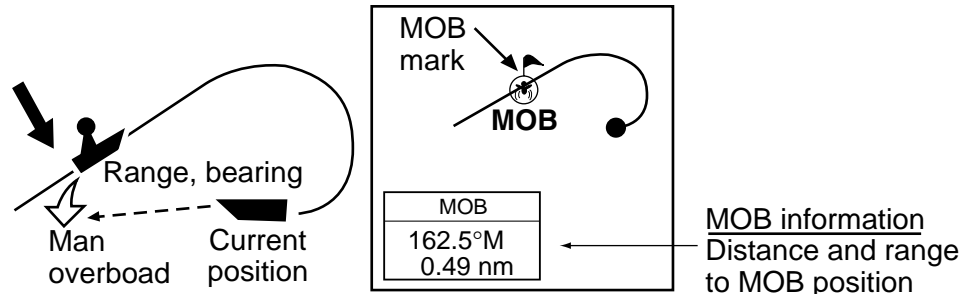

MOB concept

1. Press and hold down the [MOB/WPT] key immediately for about three seconds when someone falls onboard, to show the display below.

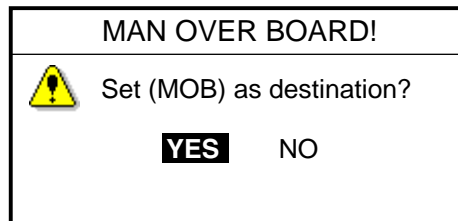

MOB message window

2. Confirm that YES is selected, and then press the [ENTER] knob to set the MOB position as the destination. (Choose NO to mark position as a waypoint.)

If you select the MOB position as the destination, the MOB ALARM window appears. Push the [ENTER] knob to erase it and then the following message appear on the display.

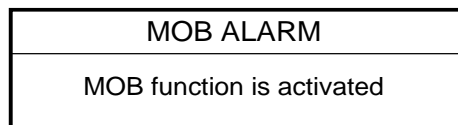

MOB ALARM window

When placing the cursor on the MOB mark, distance and bearing to the MOB position are shown in the MOB data box.

FIX →  MOB	
33° 07. 674N 132° 51. 766W	
DST	BRG
1.14 nm	187 ° M

MOB data box

1.7.2 Deleting the MOB mark

1. Operate the cursor pad to place the cursor on the MOB mark, and then press the STOP soft key to cancel the navigation to the MOB mark.
2. Press the DELETE soft key to show the confirmation window.
3. Choose "YES", and then press the [ENTER] knob to delete the MOB mark.

1.8 Menu Operation

Most operations are carried out from the menu bar. The menu bar is opened or closed with the [MENU] key. Menus and options may be selected by rotating the [ENTER] knob or operating the cursor pad. However, this manual describes operating procedure using the [ENTER] knob.

Using the [ENTER] knob

1. Press the [MENU] key to show the menu bar.

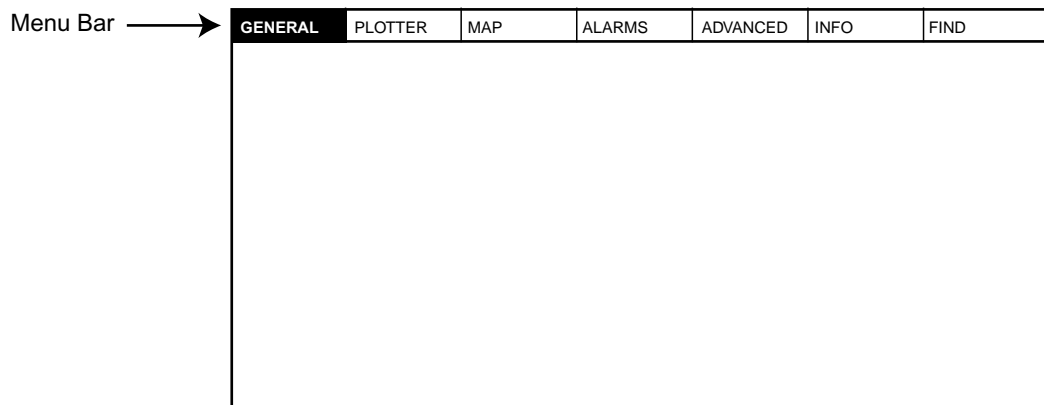

Menu bar

2. Rotate the [ENTER] knob to choose a menu title and then push the [ENTER] knob to show the menu.

For example, choose GENERAL to display the GENERAL menu.

LANGUAGE	English
KEYPAD BEEP	Off
PALETTE	Normal
TIME LINE	Infinite
TIME REFERENCE	UTC
TIME FORMAT	12hour
DATE FORMAT	MM-DD-YY
AUTO INFO	On All
SHIP ICON	
WIND GRAPH	True
UNITS OF MEASURE	

General menu

3. Rotate the [ENTER] knob to choose an item and then push the [ENTER] knob.

For example, choose LANGUAGE.

1. OPERATIONAL OVERVIEW

English
Italiano
Francais
Deutsch
Espanol
Norsk
Svensk
Portuguese

Language option window

4. Rotate the [ENTER] knob to choose the option desired and then press the [ENTER] knob.
To cancel, press the [CLEAR] key.
5. To close all menus and option windows, press the [MENU] key.
To close option windows one by one, press the [CLEAR] key.

Using the cursor pad

1. Press the [MENU] key to show the menu bar.

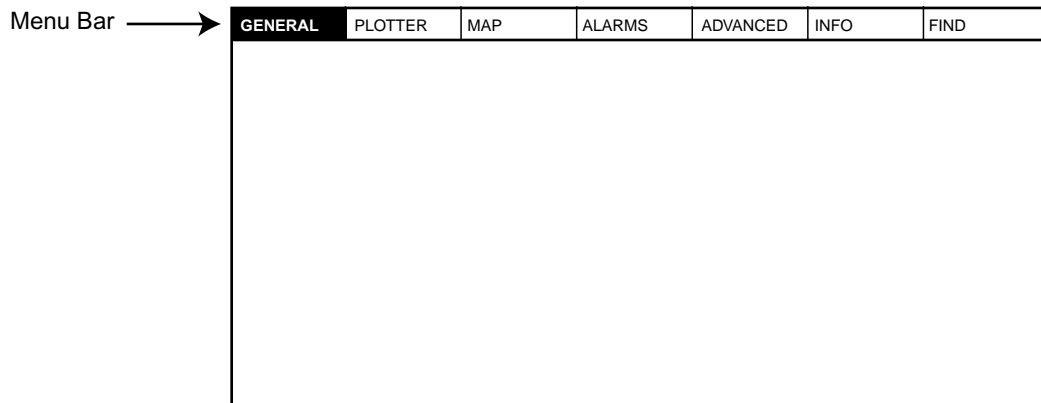

Menu bar

2. Press ◀ or ▶ on the cursor pad to choose a menu title and then press ▼ to show the corresponding menu.
For example, choose GENERAL to display the GENERAL menu.

LANGUAGE	English
KEYPAD BEEP	Off
PALETTE	Normal
TIME LINE	Infinite
TIME REFERENCE	UTC
TIME FORMAT	12hour
DATE FORMAT	MM-DD-YY
AUTO INFO	On All
SHIP ICON	
WIND GRAPH	True
UNITS OF MEASURE	

General menu

3. Press ▼ to choose an item and then press ▶ to show its option window.
For example, choose LANGUAGE.

English
Italiano
Francais
Deutsch
Espanol
Norsk
Svensk
Portuguese

Language option window

- Press ▼ to choose an option and then press ► to close the window.
To cancel, press ◀.
- To close all menus and option windows, press the [MENU] key.
To close option windows one by one, press the [CLEAR] key.

1.9 Simulation Mode

The simulation mode, which is for use by service technicians for demonstration purposes, provides simulated operation to help acquaint users with the functions of the unit. All keys are operative.

“SIMUL” appears at the bottom of the display when the simulation mode is active.

Own ship’s mark moves from the default or selected position at the speed and course set.

- Press the [MENU] key to display the menu bar.
- Rotate the [ENTER] knob to choose ADVANCED and then push the [ENTER] knob.
- Rotate the [ENTER] knob to choose GPS SIMULATION and then push the [ENTER] knob to show the following window.

SIMULATION MODE	On
COURSE	007 M
SPEED	001.0 Kts
DATE	Apr/02/04
TIME	12:00:00 AM
CURSOR CONTROL	Off
SELECT POSITION	

GPS simulation window

- Rotate the [ENTER] knob to choose SIMULATION MODE and then push the [ENTER] knob.
- Rotate the [ENTER] knob to choose On and then push the [ENTER] knob.
- Rotate the [ENTER] knob to choose COURSE and then push the [ENTER] knob.
- Enter the course (Setting range: 0 to 359) by rotating the [ENTER] knob, pressing the ◀ or ►, and then press the SAVE soft key.
To move the digit cursor, press the ◀ or ►.

1. OPERATIONAL OVERVIEW

Note: You can return the value to zero by pressing the CLR FLD soft key.

8. Enter SPEED, DATE and TIME.
9. Rotate the [ENTER] knob to choose CURSOR CONTROL and then push the [ENTER] knob.
10. Rotate the [ENTER] knob to choose On or Off as appropriate and then push the [ENTER] knob.
When On is selected, you can set course value (◀ ▶) and speed value (▲ ▼) on the plotter display.
11. Rotate the [ENTER] knob to choose SELECT POSITION and then push the [ENTER] knob.
The plotter display appears.
12. Operate the cursor pad to place the own ship marker at the desired starting point.
13. Push the [ENTER] knob.
14. Press the [CLEAR] key.

2. PLOTTER DISPLAYS

2.1 Presentation Modes

The plotter display mainly shows chart, ship's track, waypoints, and navigation data.

Three types of display presentations are provided for the normal plotter display: north-up, course-up and auto course-up. To change the mode, use the presentation mode selection soft key, which is the leftmost soft key.

2.1.1 North-up

Press the NORTH UP soft key to show the north-up display. North (zero degree) is at the top of the display.

When the cursor is on: The own ship moves. (True motion)

When the cursor is off: The chart, waypoints and other marks move. (Relative motion)

To turn the cursor off, press the CENTER soft key.

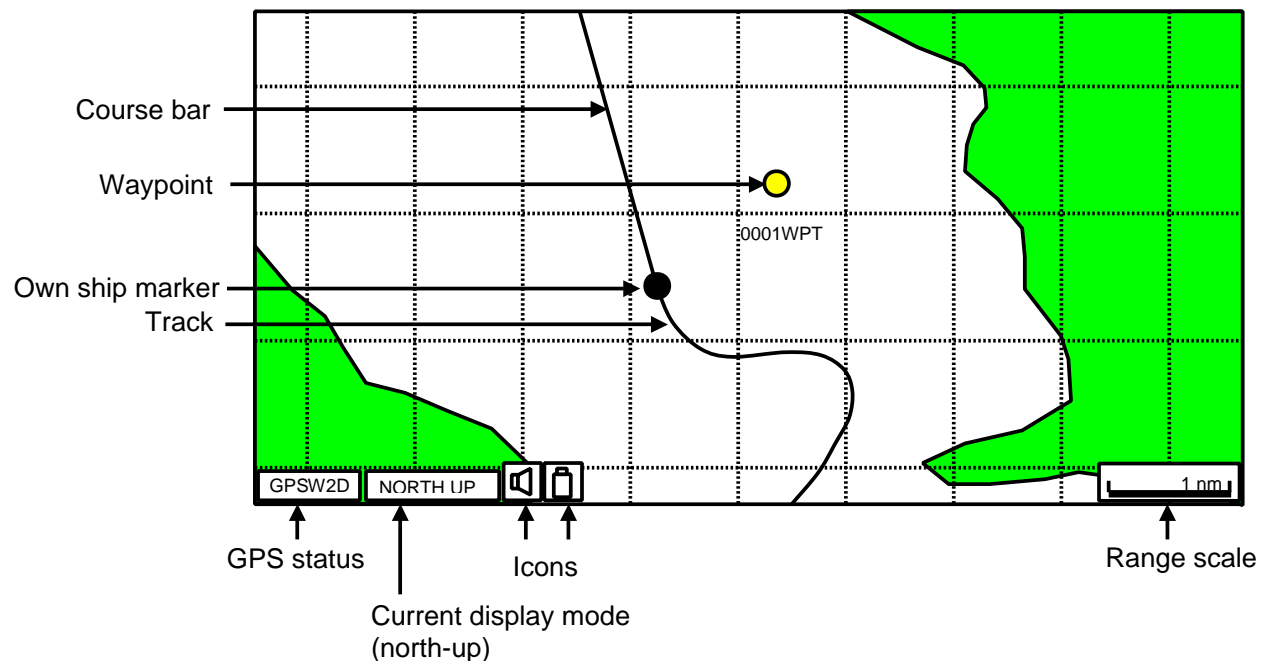

Plotter display, north-up mode

2.1.2 Course-up

Press the COURSE UP soft key to show the course-up display. When destination is set it is at the top of the screen, and the north mark appears at the upper right side of the screen and points to north.

When destination is not set, the course is upward on the screen at the moment the course-up mode is selected.



Plotter display, course-up mode

2.1.3 Auto course-up

Press the AUTO CSE UP soft key to show the automatic course-up display. The course or heading is at the top of screen at the moment the course-up mode is selected. When own ship is off its intended course by 30° (default setting, this degree can be changed on NAVIGATION menu. For details, see chapter 8.) or more, it is automatically brought back to perpendicular.

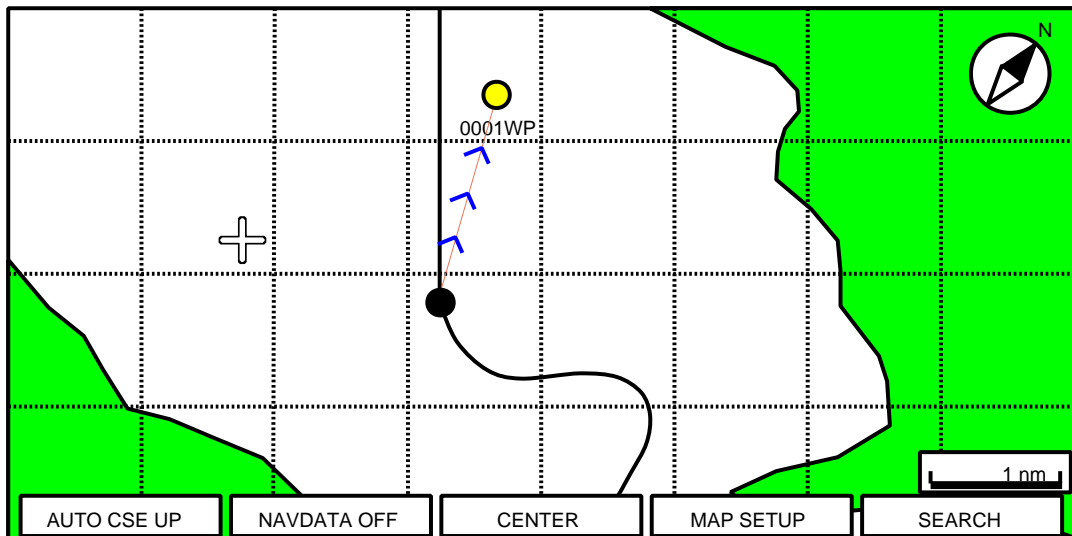

Plotter display, auto course-up mode

2.2 Cursor

2.2.1 Turning on the cursor, shifting the cursor

Press the cursor pad to turn the cursor on, and the cursor appears at the own ship's position. Operate the cursor pad to shift the cursor. The cursor moves in the direction of the arrow or diagonal pressed on the cursor pad.

Cursor state determines what data is shown in the NAVDATA window. This window can be enabled or disabled by pressing the NAVDATA ON/NAVDATA OFF soft key.

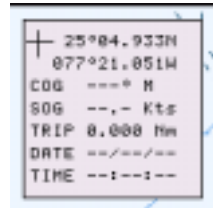

NAVDATA window

Also, when the cursor is placed on own ship's position, its data is shown as follows.

FIX			3D
33°37.125N 118°48.428W			
SOG	kts	COG	M
1.00		007°	

Own ship's position data window

2.2.2 Moving the cursor to the center of the screen

Press the CENTER soft key to return the cursor to the screen center.

2.2.3 Displaying data

Besides its fundamental functions of providing position data, the cursor can also provide data for chosen caution area, depth area, source of data, etc. Further, you can display information about an icon by placing the cursor on it.

1. Press the cursor pad to turn the cursor on.
2. Use the cursor pad to place the cursor on the position desired.

The object information window appears.

Object Info	
Wreck	++ ++

Object information window (ex. wreck)

3. If you want to know more details, press the Details soft key.

Objects	
<ul style="list-style-type: none"> Wreck - Caution area - Depth area - Military practice area - Sea area - Source of data 	<div style="border: 1px solid black; width: 40px; height: 40px; margin: 0 auto;"> <div style="text-align: center; margin: 5px 0;">++ ++</div> </div>
Wreck	
Category of wreck non-dangerous wreck Water level effect always under water/submerged	

Object detail window (ex. wreck)

4. Rotate the [ENTER] knob to choose the item you want to know more about.
Detailed information appears in the lower column.
5. Press the [CLEAR] key to close the window.

2.3 Selecting Chart Scale/Range

Chart scale (range) may be selected with the [RANGE] key. The [RANGE +] key zooms in the chart; [RANGE -] key zooms out it.

2.4 Navigation Data Display

The navigation data display provides generic navigation data, and it is shown in combination displays.

Appropriate sensors are required. Bars (- -) appear when corresponding sensor is not connected.

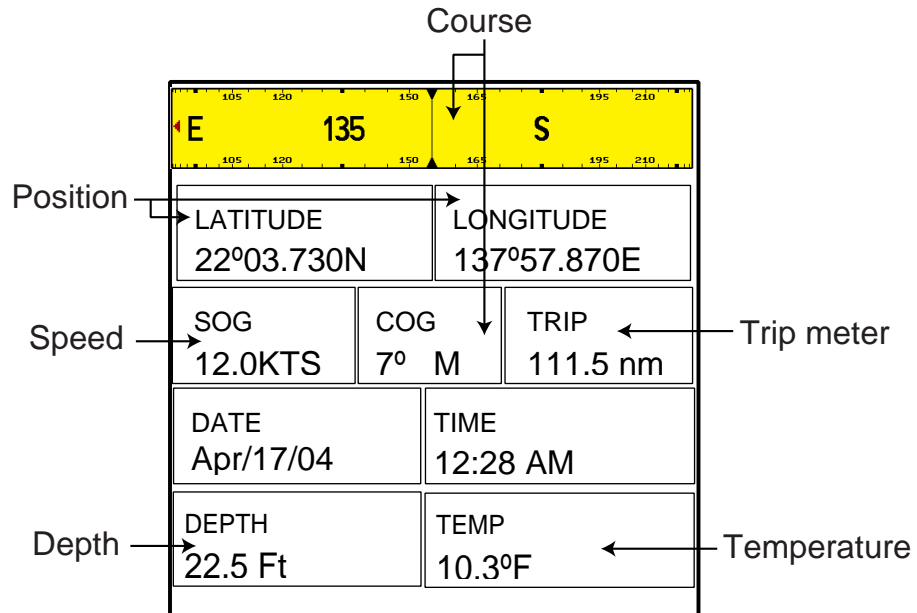

Navigation data display

Changing the information displayed

1. Press and hold the [MENU] key down for two seconds to show Speed in reverse video.
2. Rotate the [ENTER] knob to show data in reverse video.
3. Press the [ENTER] knob to show the selection window as shown below.

SOG	WSA
COG	WDA
STW	DATE
HDG	TIME
DST	TTG
BRG	ETA
TRIP	DEST
DEPTH	
TEMP	
HDOP	
VDOP	
XTE	
DRF	
SET	
WST	
WDT	

Note: Contents may be changed depending on data selected at step2.

4. Rotate the [ENTER] knob to choose the data to show, and then press it. The item window (ex. units) appears.
5. Rotate [ENTER] knob to select the unit. The data selected at step 2 changes to your selection.
6. Press the [CLEAR] key to erase the reverse video.

2.5 Compass Display

The compass display, shown in combination displays, provides steering information. The compass rose shows two triangles: the red triangle shows own ship's course and the black triangle, which moves with ship's course, shows the bearing to destination waypoint.

The water temperature and depth graphs, which require appropriate sensors, shows the latest 10 minutes of water temperature and depth data.

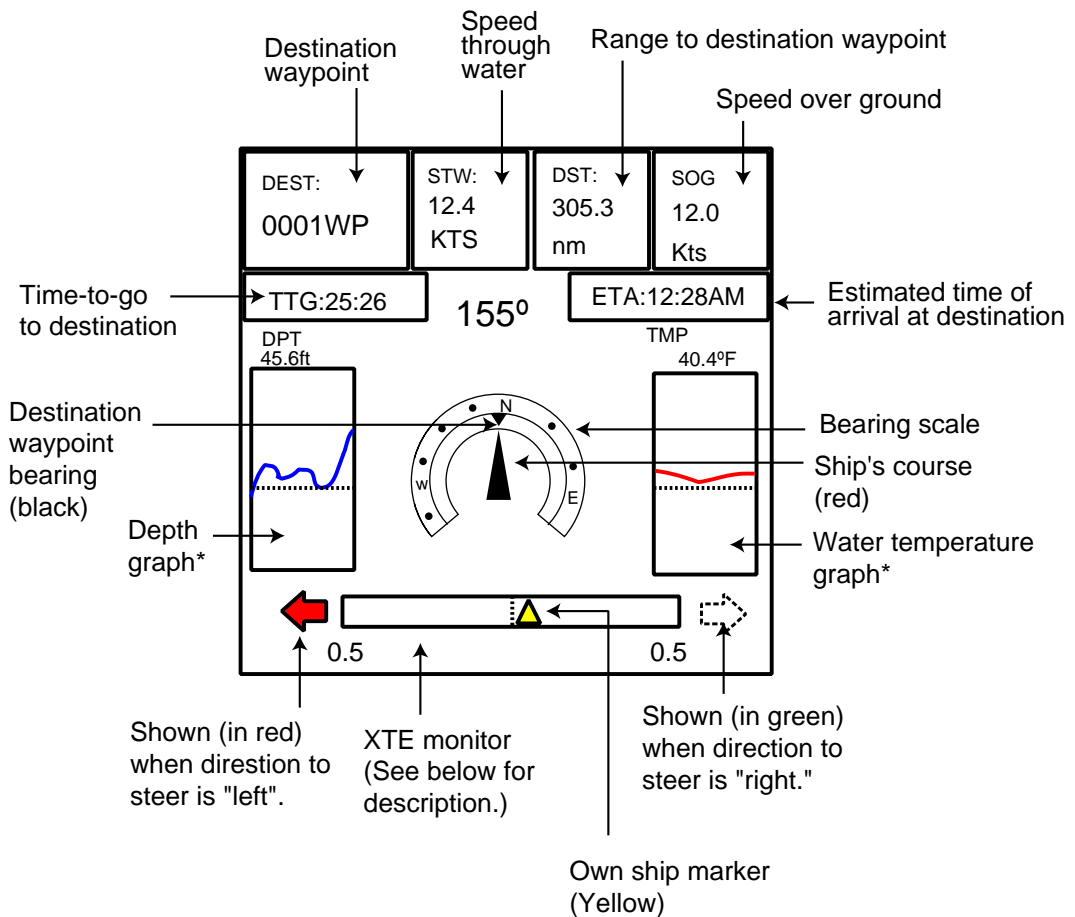

Compass distance

Reading the XTE (cross-track error) monitor

The XTE monitor, located below the compass rose, shows the distance you are off course and the direction to steer to return to course. The own ship marker in the monitor moves according to direction and distance off course. An arrow appears at the right or left side of the XTE monitor and it shows the direction to steer to return to intended course. It is shown in red when you should steer left, and green when you should steer right. In the example above you would steer left to return to course. To maintain course, steer the vessel so the own ship marker stays at the center of the XTE monitor. Note that the XTE range can be changed by rotating the [ENTER] knob.

2.6 Highway Display

The highway display, shown in combination display with the plotter screen, provides a graphic presentation of ship's track along intended course. It is useful for monitoring ship's progress toward a waypoint. The own ship marker shows the relation between your vessel and intended course.

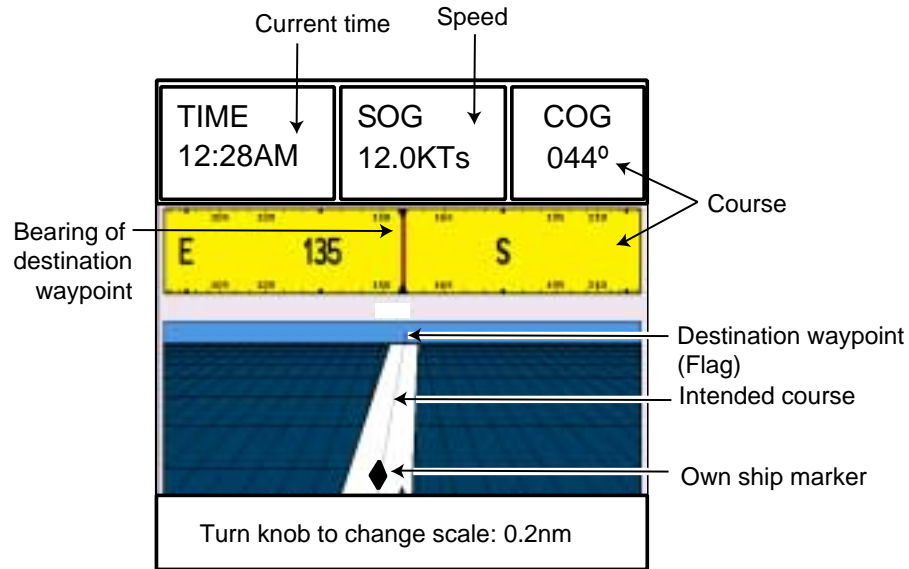

Highway display

Changing the scale

You can change the scale of the highway display to 0.2, 0.5, 1.0 or 2.0 (nm). Rotate the [ENTER] knob to change it. Note that the available range depends on own ship's position.

2.7 GPS Status Display

The GPS status display provides data on the GPS satellites.

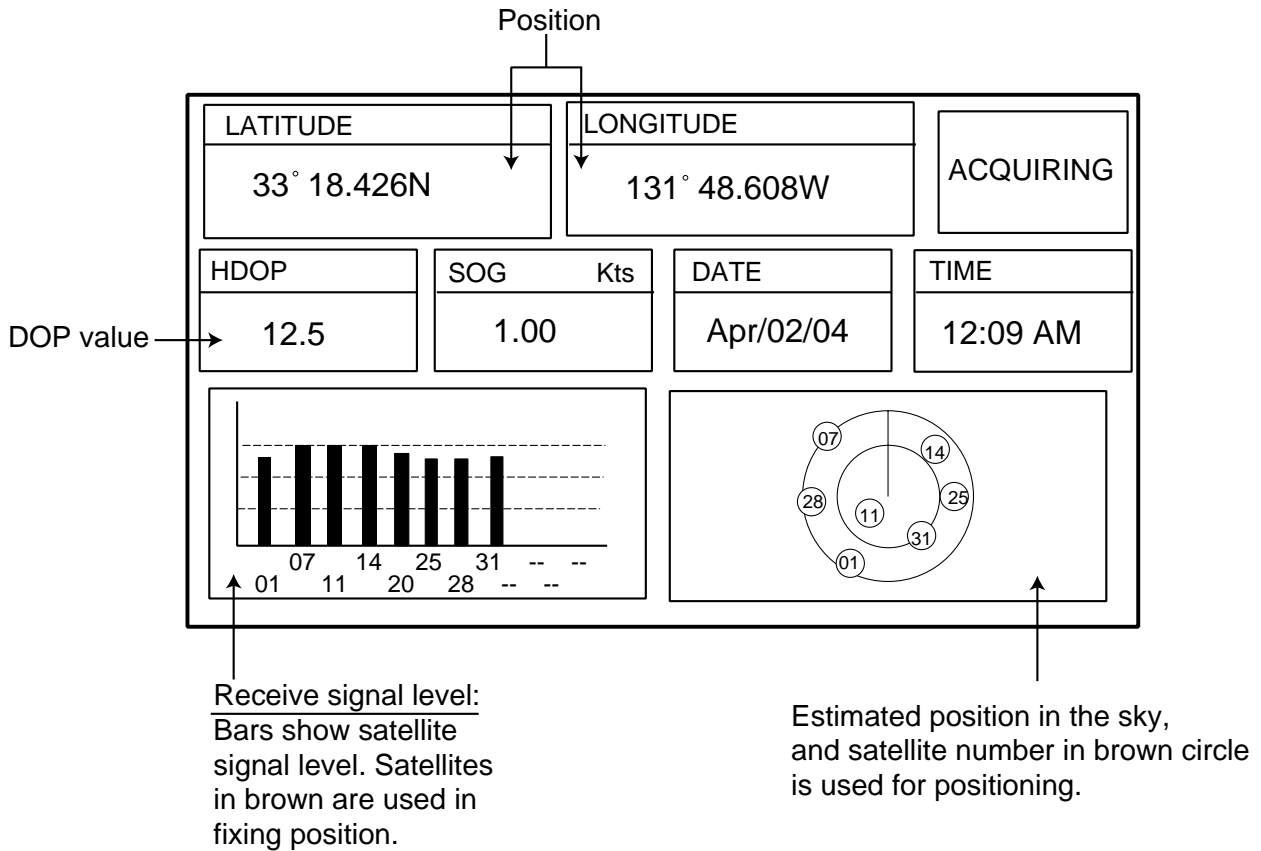

GPS status display

2.8 Celestial Display

Your plotter provides for calculation of the tide heights for any date. Additionally it displays the time of sunrise, sunset, moonrise and moonset.

Nearest Tide Station:			
High Water	-----	-.-. Ft	
Low Water	-----	-.-. Ft	
From tide	--- nm	--- °M	
Sunrise:	03:50 PM U	 Moon phase 50%	
Sunset:	01:49 AM U		
Moonrise:	10:29 AM U		
Moonset:	10:07 PM U		
33°20.435N 131°48.608W		Date Time	April-01-2004 02:35 AM
ENTER to change Date - Turn the KNOB to set [DLS/STANDARD] time			

Celestial display

Setting the date for calculation

1. Press the [ENTER] knob to show the date window.

MM-DD-YY
04/09/04

Date window

2. Press the cursor pad to move the cursor, and then rotate the [ENTER] knob to choose the date.

When you want to clear all values, press the CLR FLD soft key.

To escape, press the CANCEL soft key.

3. Press the SAVE soft key to set.

2.9 Graph Display

Four graphs can be displayed alternately on the half-screen of the LCD: depth, wind, water temperature and SOG (speed).

Press the GRAPH TYPE soft key to choose display graphs in the sequence shown below.

Note: Appropriate sensors required to display graphs.

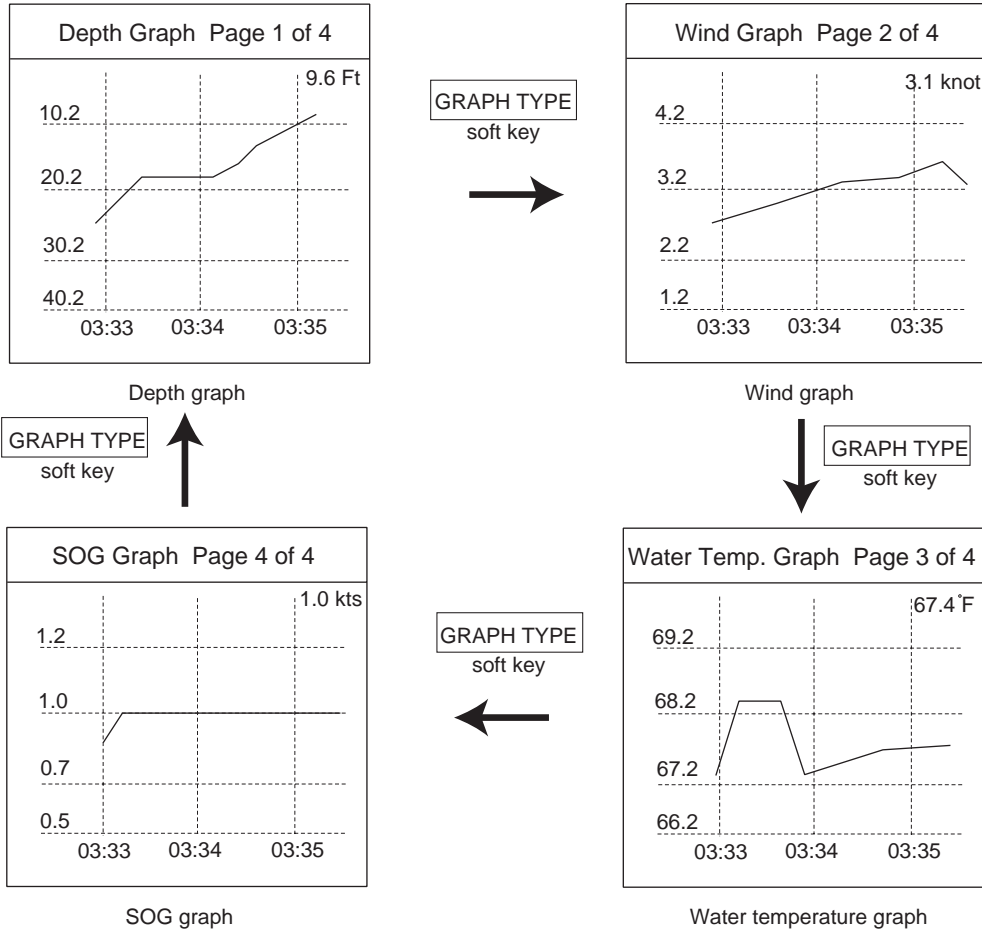

Sequence of graph display

2.10 Wind Display

Your plotter can show the graphical wind indicator when the appropriate data is input.

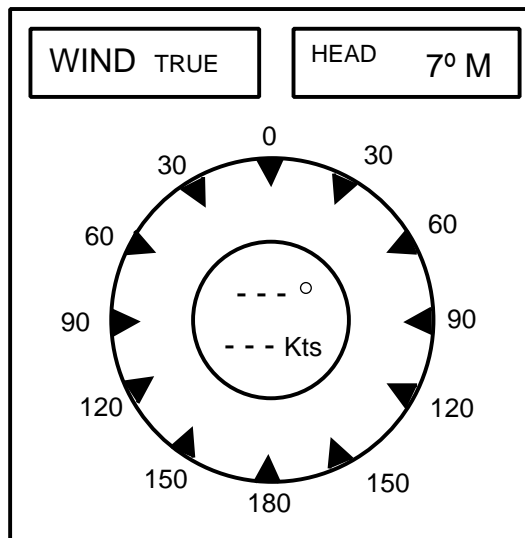

Wind display

Selecting the wind direction indication format

The wind direction can be selected to true or apparent.

1. Press the [MENU] key to show the menu bar.
2. Rotate the [ENTER] knob to choose GENERAL and then push the [ENTER] knob.
3. Rotate the [ENTER] knob to choose WIND GRAPH and then push the [ENTER] knob.
4. Rotate the [ENTER] knob to select True or Apparent as appropriate.
 - True: The Speed and direction (relative to due north)
 - Relative: The direction (in relation to ship's bow) and speed of the wind as it appears to those on board, relative to the speed and direction of the boat; combination of the true wind and the wind caused by the boat's movement.
5. Push the [ENTER] knob.
6. Press the [MENU] key to close the menu.

2.11 NAVDATA Window

The second soft key from the left functions to control the NAVDATA window. Each press of the key changes this soft key label in the sequence of NAV DATA, NAV+CUR and OFF.

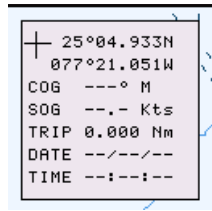

NAVDATA window

Customizing the NAVDATA window

1. Press the NAV DATA soft key to show the NAVDATA window if it is not already shown.
2. Press and hold the [MENU] key down for two seconds.

The data beneath the cursor position is shown in reverse video.
3. Rotate the [ENTER] knob to select the data to change, and then press it.

A data window similar to the one shown on page 2-5 appears.
4. Rotate the [ENTER] knob to choose data, and then press it.
5. Depending on the data selected, a unit window may appear. In this case, rotate the [ENTER] knob to choose the desired unit, and then press it.
6. Press the [CLEAR] key to erase the reverse video.

Resetting the trip data

1. Press the NAV DATA soft key to show the NAVDATA window if it is not already shown.
2. Press and hold the [ENTER] knob down for two seconds.
3. Rotate the [ENTER] knob to choose TRIP, and then press it.
4. Confirm that TRIP is shown in reverse video in the list, and then press the [ENTER] knob.
5. Rotate the [ENTER] knob to choose Reset, and then press it.
6. Confirm that YES is shown in reverse video, and then press the [ENTER] knob.
7. Press the [CLEAR] key to close the window.

3. TRACK

Your ship's track is plotted on the screen using navigation data fed from the internal GPS navigator. This chapter shows you what you can do with track, from turning it on or off to changing its plotting interval. In the default setting, own ship's track is turned on and is displayed in black.

3.1 Selecting Active Track

Your plotter can plot up to five track lines. It can be useful to have multiple track lines to distinguish tracks according to date or course. Note that other track-related settings are available for the track chosen here.

1. Press the [MENU] key to show the menu bar.

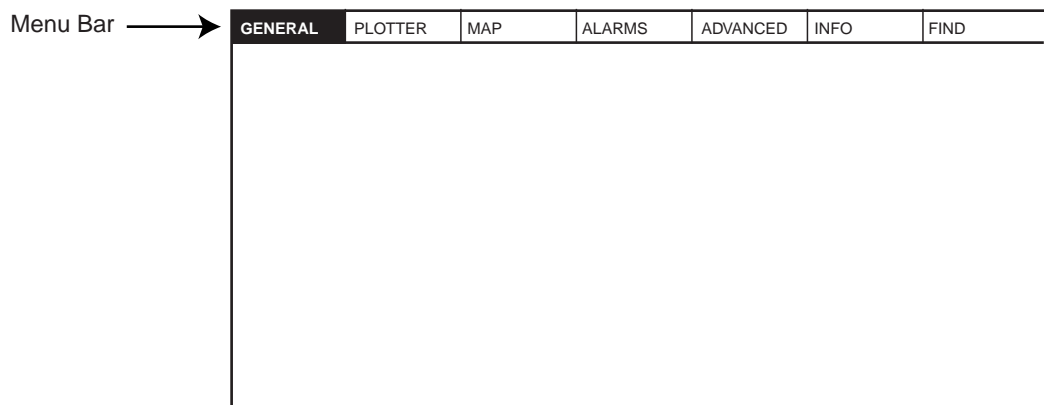

Menu bar

2. Rotate the [ENTER] knob to choose PLOTTER from the menu bar.
3. Push the [ENTER] knob to show the PLOTTER menu.

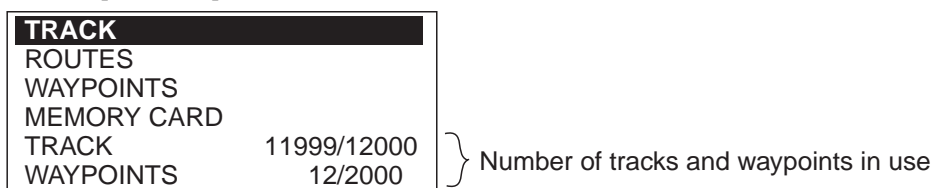

Plotter menu

4. Rotate the [ENTER] knob to choose TRACK and then push the [ENTER] knob.

TRACKING	Off
ACTIVE TRACK	1
VISIBLE	On
LINE COLOR	_____
DELETE	
STEP UNIT	Dist
DISTANCE	0.1 Nm
TIME	1 min

Track menu

3. TRACK

5. Rotate the [ENTER] knob to choose ACTIVE TRACK and then push the [ENTER] knob.
6. Rotate the [ENTER] knob to choose the desired number of own ship tracks to use, from among 1 to 5.
7. Press the SAVE soft key.
8. Press the [MENU] key to close the menu.

3.2 Displaying Track

To display track line on the screen, do the following.

1. Press the [MENU] key to show the menu bar.
2. Rotate the [ENTER] knob to choose PLOTTER from the menu bar and then push the [ENTER] knob.
3. Rotate the [ENTER] knob to choose TRACK and then push the [ENTER] knob.
4. Rotate the [ENTER] knob to choose TRACKING and then push the [ENTER] knob.
5. Rotate the [ENTER] knob to select On and then push the [ENTER] knob.
To turn off the track display, select Off here.
6. Press the [MENU] key to close the menu.

3.3 Changing Track Color

Track can be displayed in black (default setting), light-green, red, purple, yellow, gray, brown and dark green. It can be useful to change track color on a regular basis to discriminate the active tracks.

1. Choose TRACK from the PLOTTER menu and then push the [ENTER] knob.
2. Choose LINE COLOR and then push the [ENTER] knob.
3. Rotate the [ENTER] knob to choose the color desired and then push the [ENTER] knob.
4. Press the [MENU] key to close the menu.

3.4 Stopping, Restarting Plotting

When your boat is at anchor or returning to port, you probably won't need to record its track. You can stop recording the track, to conserve the track memory, as below.

1. Choose TRACK from the PLOTTER menu and then push the [ENTER] knob.
2. Choose TRACKING and then push the [ENTER] knob.
3. Rotate the [ENTER] knob to choose Off, and then push the [ENTER] knob.

3.5 Hiding the Track

The track lines can be hidden (but recorded). This function is useful when there are too many tracks to distinguish on the screen and it is hard to distinguish one from another.

1. Choose TRACK from the PLOTTER menu and then push the [ENTER] knob.
2. Choose VISIBLE and then push the [ENTER] knob.
3. Rotate the [ENTER] knob to select On.
To re-display the track, choose Off.
4. Press the [MENU] key to close the menu.

3.6 Track Plotting Method and Interval

In drawing the own ship track, first the ship's position fed from the internal GPS navigator is stored into the unit's memory at an interval of time or distance. A shorter interval provides for better reconstruction of the track, but the storage time of the track is reduced. When the track memory becomes full, the oldest track is erased to make room for the latest.

3.6.1 Track plotting method

Track may be plotted by time or distance.

1. Choose TRACK from the PLOTTER menu.
2. Choose STEP UNIT and then push the [ENTER] knob.



STEP UNIT window

3. Rotate the [ENTER] knob to select Dist (distance) or Time as appropriate.
Distance is useful for conserving track memory, since no track is recorded when the boat is stationary.
4. Push the [ENTER] knob.
5. Press the [MENU] key to close the menu.

3. TRACK

3.6.2 Track plotting interval

1. Choose TRACK from the PLOTTER menu.
2. Choose DISTANCE or TIME as appropriate and then push the [ENTER] knob.

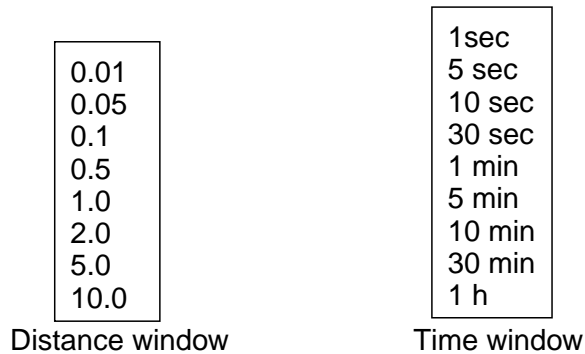

Interval windows

3. Rotate the [ENTER] knob to select setting.
4. Push the [ENTER] knob.
5. Press the [MENU] key to close the menu.

3.7 Erasing Track

This section shows you how to erase the active track.

1. Choose TRACK from the PLOTTER menu.
2. Choose DELETE and then push the [ENTER] knob.

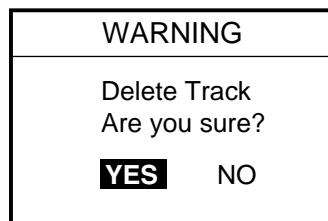

Delete window

3. Push the [ENTER] knob to erase the track.
To cancel, rotate the [ENTER] knob to choose NO and then push the [ENTER] knob.
4. Press the [MENU] key.

4. WAYPOINT

In navigation terminology, a waypoint is a particular location on a voyage whether it be a starting, intermediate or destination point. A waypoint is the simplest piece of information your equipment requires to get you to a destination, in the shortest distance possible.

This unit has 2,000 waypoints into which you can enter position information. You may enter a waypoint four ways: at own ship position, by cursor, at MOB position (see chapter 1) and through the waypoint list (manual input of latitude and longitude).

4.1 Entering Waypoints

4.1.1 Entering a waypoint at own ship position or cursor position

Turn the cursor off to enter a waypoint at own ship position, or turn it on to enter a waypoint at cursor position.

A newly entered waypoint is saved to the waypoint list, under the youngest empty waypoint number.

1. Press the [MOB/ WPT] key momentarily to store your position as a waypoint. When the cursor is displayed, the waypoint is entered at the cursor position.

The new waypoint window appears and it shows waypoint name, position of waypoint, waypoint mark shape and comment for newly entered waypoint.

NAME 0004WP
LATITUDE/LONGITUDE 47° 56.307N 133° 56.807W
SHAPE COLOR
COMMENT 00:29 APR0204

Waypoint window

2. If you do not need to change the waypoint data, press the SAVE soft key to register the waypoint. The steps which follow show you how to change waypoint data.
3. NAME is selected; push the [ENTER] knob.

4. WAYPOINT

4. Rotate the [ENTER] knob to choose the desired alphanumeric character.
You can clear all digits in the field by pressing the CLR FLD soft key.
5. Press ► to move the cursor to the next digit, and then rotate the [ENTER] knob to choose the character desired.
6. Repeat steps 4 and 5 to complete the name. (Max. 12 characters)
7. Press the SAVE soft key and then rotate the [ENTER] knob to choose the LATITUDE/LONGITUDE section.
8. Push the [ENTER] knob.
9. Use the cursor pad and [ENTER] knob to enter latitude data, and then press the SAVE soft key.
10. Use the cursor pad and [ENTER] knob to enter longitude data, and then press the SAVE soft key.
11. Rotate the [ENTER] knob to choose “SHAPE” in the SHAPE/COLOR section.
12. Push the [ENTER] knob to show the waypoint mark shape selection window.

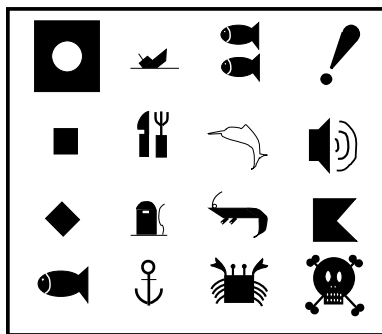

Waypoint mark shape selection window

13. Rotate the [ENTER] knob to choose shape desired.
14. Push the [ENTER] knob.
15. Rotate the [ENTER] knob to choose “COLOR” and then push the [ENTER] knob.

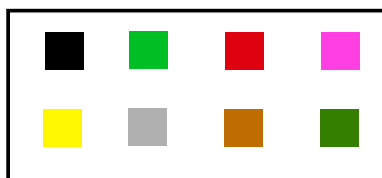

Waypoint mark color selection window

16. Rotate the [ENTER] knob to choose the color desired, then push the [ENTER] knob.
17. Rotate the [ENTER] knob to choose COMMENT section and then push the [ENTER] knob.
18. Use the cursor pad and [ENTER] knob to enter a comment (Max. 13 characters).
19. Press the SAVE soft key twice to register the waypoint.

4.1.3 Entering a waypoint/MOB mark with an external event switch

If the equipment is equipped with an external event switch you may choose what mark is inscribed on the screen when the switch is pressed. The choices are Waypoint, MOB mark or Off (no event switch is connected).

1. Press the [MENU] key to show the menu bar.
2. Rotate the [ENTER] knob to choose ADVANCED from the menu bar and then push the [ENTER] knob.
3. Rotate the [ENTER] knob to choose INPUT/OUTPUT and then push the [ENTER] knob.
4. Rotate the [ENTER] knob to choose EXTERNAL EVENT and then push the [ENTER] knob.

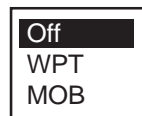

5. Choose Off, WPT or MOB as appropriate and then push the [ENTER] knob.
6. Press the [MENU] key to close the menu.

4.2 Editing Waypoint Data

Waypoint data may be edited from the waypoint list or directly from the plotter display.

4.2.1 Editing waypoint data from the waypoint list

1. Press the [MENU] key to show the menu bar.
2. Rotate the [ENTER] knob to choose PLOTTER and then push the [ENTER] knob.
3. Rotate the [ENTER] knob to choose WAYPOINTS and then push the [ENTER] knob to show the WAYPOINT LIST.
4. Press the cursor pad (▲▼) to choose the waypoint you want to edit.
5. Rotate the [ENTER] knob to choose EDIT at the bottom of screen.
6. Push the [ENTER] knob.
7. Press the cursor pad (◀▶) to place the cursor on the appropriate column, and then push the [ENTER] knob.
8. Edit data as appropriate, and then push the [ENTER] knob.
9. Press the [CLEAR] key to close the list.

4.2.2 Editing a waypoint from the plotter display

You may edit waypoints from the plotter display two ways: from the waypoint window or directly on the plotter display.

From waypoint window

1. Operate the cursor pad to place the cursor on the waypoint you want to edit.
2. Press the EDIT soft key to show the waypoint window.

NAME 0004WP	
LATITUDE/LONGITUDE 47°56.307N 133°56.807W	
SHAPE COLOR	■
COMMENT 00:29 APR0204	

Waypoint window

3. Edit data as appropriate referring to paragraph 4.1.1, and then press the SAVE soft key.

Directly on plotter display

Operate the cursor pad to place the cursor on the waypoint to edit, and then press the MOVE soft key. The color of the selected waypoint changes to blue, and black line runs between it and the cursor. Operate the cursor pad to select the new position, and then push the [ENTER] knob.

4.3 Erasing Waypoints

Waypoints can be erased from the waypoint list or directly from the plotter display.

4.3.1 Erasing a waypoint directly from the plotter display

1. Press the cursor pad to place the cursor on the waypoint you want to delete.
2. Press the DELETE soft key.

The following window appears.

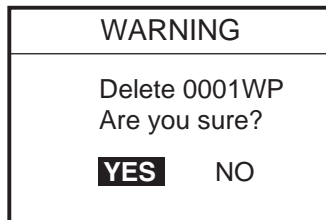

3. Push the [ENTER] knob.

The color of the selected waypoint at step 1 changes to blue. To erase completely, press the [RANGE] key.

4.3.2 Erasing a waypoint from the waypoint list

1. Press the [MENU] key to show the menu bar.
2. Choose PLOTTER followed by WAYPOINTS, and then push the [ENTER] knob to show the WAYPOINT LIST.
3. Press the cursor pad (▲▼) to choose the waypoint you want to delete.
4. Rotate the [ENTER] knob to choose DELETE at the bottom of the screen, and then push the [ENTER] knob.



5. Rotate the [ENTER] knob to select DELETE SELECTED, and then push the [ENTER] knob.

If you want to delete all waypoints in the list, choose DELETE ALL.

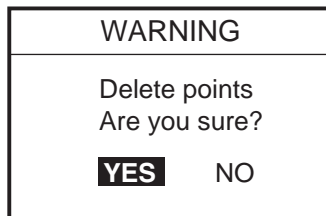

6. You are asked if you are sure to delete selected waypoint (s). Push the [ENTER] knob to delete, or choose NO and push the [ENTER] knob to escape.
7. Press the [CLEAR] key to finish.

4.4 Searching, Sorting Waypoints

You can search and sort waypoints on the waypoint list as follows.

Searching by waypoint name

1. Open the WAYPOINT LIST.
2. Rotate the [ENTER] knob to choose SEARCH at the bottom of the screen.
3. Push the [ENTER] knob.
4. Enter the waypoint name you want to find, and then press the SAVE soft key.
The cursor moves on the chosen waypoint name on the list.
5. Press the [CLEAR] key to close the list.

Sorting waypoints

1. Open the WAYPOINT LIST.
2. Rotate the [ENTER] knob to choose SORT at the bottom of the screen.
3. Push the [ENTER] knob to show the item window.

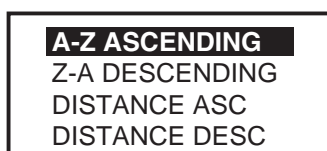

Sort window

4. Rotate the [ENTER] knob to choose a sorting method.
 - A-Z ASCENDING:** Sorting waypoints in ascending alphanumeric order.
 - Z-A DESCENDING:** Sorting waypoint in descending alphanumeric order.
 - DISTANCE ASC:** Sorting waypoints in order of increasing distance to own ship.
 - DISTANCE DESC:** Sorting waypoints in order of decreasing distance to own ship.
5. Push the [ENTER] knob.
6. Press the [CLEAR] key to close the list.

4.5 Other Waypoint List Functions

This section shows you how to execute the various functions available on the WAYPOINT LIST.

4.5.1 Filtering waypoints by mark shape

You may filter waypoints in the waypoint list by mark shape. This is useful when you are looking for waypoints of a specific shape.

1. Open the WAYPOINT LIST.
2. Rotate the [ENTER] knob to choose ICON at the bottom of screen.
3. Push the [ENTER] knob to show the ICON window.

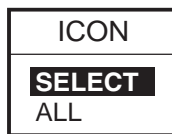

Icon window

4. Rotate the [ENTER] knob to choose SELECT and then push the [ENTER] knob.

The waypoint mark shape selection window appears.

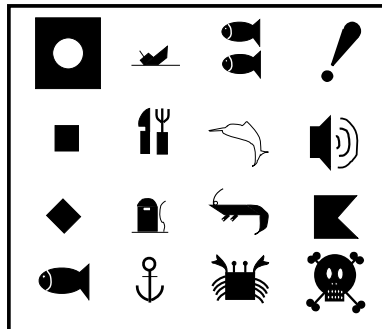

Waypoint mark shape selection window

Note: ALL shows all waypoints.

5. Rotate the [ENTER] knob to choose the mark shape which you want to search, and then push the [ENTER] knob.

The list shows waypoints with the chosen mark shape.

6. Press the [CLEAR] key twice to close the list.

To display all waypoints, choose ALL at step 4 and then press the [CLEAR] key.

4.5.2 Hiding or showing waypoints

Waypoints can be shown or hidden individually or collectively on the plotter display as below.

1. Open the WAYPOINT LIST.
2. Press the cursor pad (▲▼) to choose the waypoint you want to show or hide.

All waypoints can also be shown or hidden.

3. Rotate the [ENTER] knob to choose MODE at the bottom of screen, and then push the [ENTER] knob.

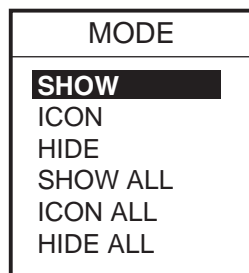

Mode window

4. Rotate the [ENTER] knob to choose option desired.
 - SHOW:** Shows the name and mark of the waypoint selected at step 2.
 - ICON:** Shows only the mark of the waypoint selected at step 2.
 - HIDE:** Hides the name and mark of the waypoint selected at step 2.
 - SHOW ALL:** Shows the names and marks of all waypoints.
 - ICON ALL:** Shows only marks of all waypoints.
 - HIDE ALL:** Hides the names and marks of all waypoints.
5. Push the [ENTER] knob.
6. Press the [CLEAR] key to close the menu.

4.5.3 Searching waypoints

You can search for waypoint by name as follows.

1. Open the WAYPOINT LIST.
2. Press the cursor pad (▲▼) to choose the waypoint desired.
3. Choose PLOT at the bottom of the screen.
4. Push the [ENTER] knob.

The plotter display appears with the waypoint chosen at step 2 at the screen center.

4. WAYPOINT

This page is intentionally left blank.

5.3 Connecting Routes

Two routes which you have created can be connected as follows to form a new route.

1. Open the route menu.
2. Rotate the [ENTER] knob to choose CONNECT at the bottom of screen and then push the [ENTER] knob.

The connect route menu appears.

0001RT _____ 09:21_JAN1903	LENGTH 3.07 nm WAYPOINTS 25	CONNECT ROUTE
0002RT _____ 15:07_JAN1903	LENGTH 3.07 nm WAYPOINTS 25	
0003RT _____ 16:49_APR0103	LENGTH 3.07 nm WAYPOINTS 25	
0004RT _____ 14:09_JUL0203	LENGTH 3.07 nm WAYPOINTS 25	
0005RT _____ 14:27_JUL0203	LENGTH 3.07 nm WAYPOINTS 25	
SORT Push [MENU] key to execute		FIRST ----- FORWARD ↓
		SECOND ----- FORWARD
FORW<->RVRS	SET ROUTE	SEARCH NAME
		SAVE
		CANCEL

Connect route menu

3. Rotate the [ENTER] knob to choose the first route and then push the [ENTER] knob.
The selected route name is shown in the "FIRST" window.
4. Press the FORW <-> RVRS soft key to select the direction to follow the waypoints of the route, forward or reverse.
5. Press ▼ to place the cursor on the "SECOND" window.
6. Rotate the [ENTER] knob to choose the second route, and then push the [ENTER] knob.
7. Press the SAVE soft key.
8. Press the [CLEAR] key twice to close the menu.

Note: The maximum number of waypoints in a route is 35. If this number is exceeded an error message appears. In this case, delete waypoints in one or both routes so the total number of waypoints does not exceed 35.

Inserting a waypoint from the plotter display

You can insert a waypoint in a route directly on the screen.

1. Press the cursor pad to place the cursor on the desired line between waypoints in a route.

The window below appears.

ROUTE: 1 [0001RT] 0001WP - 0002WP
DST: 4.74 nm BRG: 102 M

Leg window (ex.)

2. Press the INSERT soft key.
The selected line (dashed) turns red.
3. Operate the cursor pad to place the cursor on an existing waypoint and then push the [ENTER] knob.
4. Press the SAVE soft key.

The route is then redrawn to include the newly inserted waypoint.

5.5 Removing Waypoints from a Route

Removing a waypoint from the route list

1. Show the route list.
2. Press the cursor pad (▲▼) to choose a route.
3. Rotate the [ENTER] knob to select EDIT at the bottom of screen and then push the [ENTER] knob to show the route menu.
4. Press the cursor pad (▲▼) to choose the waypoint you want to remove.
5. Press the DELETE soft key.
6. Press the SAVE soft key.
7. Press the [CLEAR] key to close the list.

Removing a waypoint from the plotter display

1. Press the cursor to place the cursor on the waypoint you want to remove from a route.
2. Press the DELETE soft key.

WARNING
Delete 0001WP Are you sure?
YES NO

3. Push the [ENTER] knob.
The route is redrawn, eliminating the waypoint removed.

5.6 Information on Route Report

The route report provides various information about routes, such as time distance and necessary fuel to go to a waypoint in route.

1. Open the route list.
2. Press the cursor pad (▲▼) to choose the route desired.
3. Rotate the [ENTER] knob to choose REPORT at the bottom of screen and then push the [ENTER] knob.

The route report for the route appears.

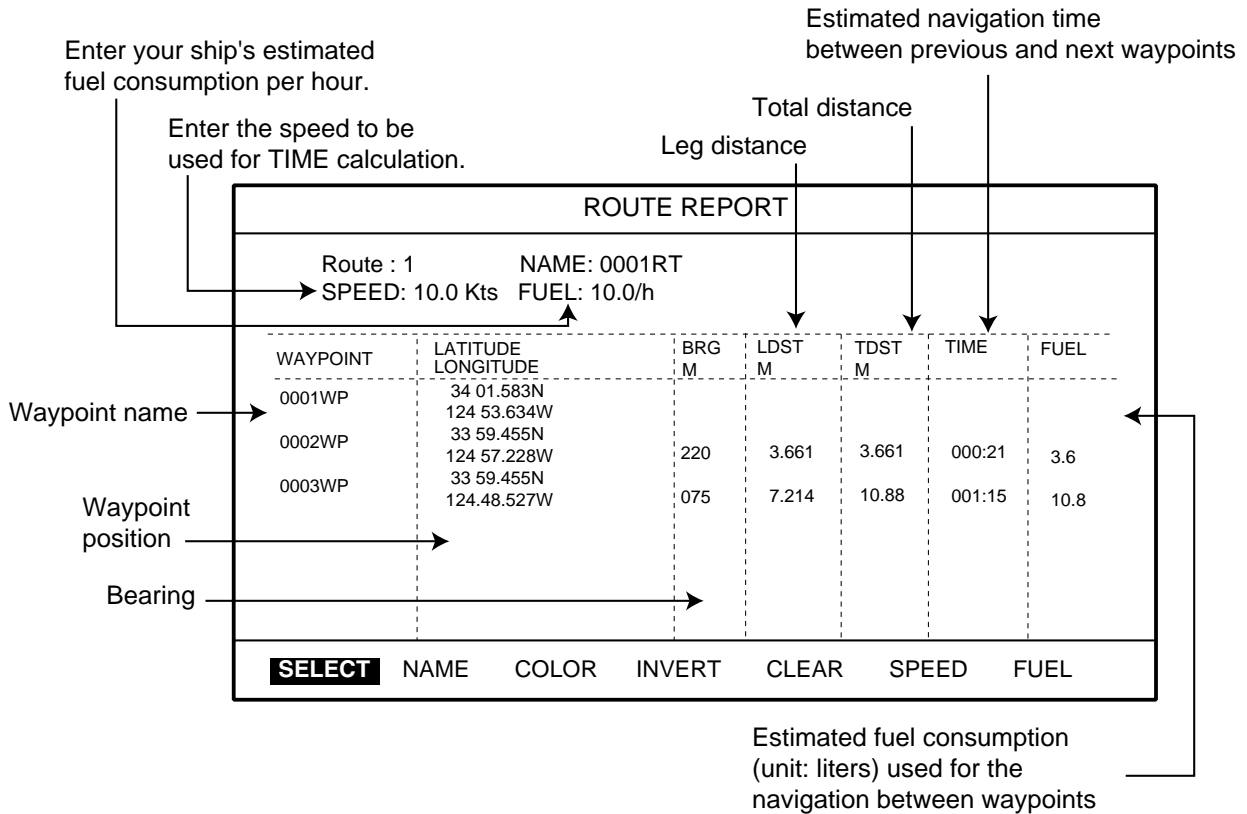

Route report

4. Press the [CLEAR] key twice to close the route report.

Entering the speed for TIME column

Enter speed to be used for TIME calculation.

1. Show the route report.
2. Rotate the [ENTER] knob to choose SPEED at the bottom of screen and then push the [ENTER] knob to show the SPEED window.

SPEED **1**0.0 kt

You can change the digit by pressing the cursor pad (◀▶).

3. Enter the ship's speed and then SAVE soft key.

Entering the fuel consumption for FUEL column

Enter your ship's estimated fuel consumption per hour to calculate fuel consumption used for the route navigation.

1. Show the route report.
2. Rotate the [ENTER] knob to choose FUEL at the bottom of screen and then push the [ENTER] knob to show the FUEL window.

FUEL **0**10.0 kt

3. Enter the fuel consumption of your boat.

You can change the digit by pressing the cursor pad (◀▶).

4. Press the SAVE soft key.

5.7 Changing the Color of Route Line

You can select the color for the route line among 8 colors: black, light-green, red, purple, yellow, gray, brown and dark green.

1. Open the route list.
2. Press the cursor pad (▲▼) to choose a route.
3. Rotate the [ENTER] knob to choose COLOR at the bottom of screen and then push the [ENTER] knob.

The color window appears.

4. Rotate the [ENTER] knob to choose a color.
5. Push the [ENTER] knob.
6. Press the [CLEAR] key to close the menu.

5.8 Searching Routes

You can search for a route through the route list or on the plotter display.

Searching a route through the route list

1. Open the route list.
2. Rotate the [ENTER] knob to choose SEARCH at the bottom of screen.
3. Push the [ENTER] knob.

The NAME window appears.



Name window

4. Enter the route name you want to search.
You can change the digit by pressing the cursor pad (◀▶).
5. Push the SAVE soft key.
The selected route name is shown at the top of the list.
6. Press the [CLEAR] key to close the menu.

Searching a route on the plotter display

1. Open the route list.
2. Press the cursor pad (▲▼) to choose the route desired.
3. Rotate the [ENTER] knob to choose PLOT at the bottom of screen.
4. Push the [ENTER] knob.
The plotter display appears with the chosen route at the screen center.

5.9 Reversing the Waypoints Order in a Route

The order of waypoints in a route can be reversed as follows.

1. Open the route list.
2. Press the cursor pad (▲▼) to choose the route desired.
3. Rotate the [ENTER] knob to choose REVERSE at the bottom of the screen.
4. Push the [ENTER] knob to reverse the waypoints order in the route.
5. Press the [CLEAR] key to close the list.

5.10 Erasing Routes

You can erase routes as follows:

1. Open the route list.
2. Press the cursor pad (▲▼) to choose the route you want to erase.
3. Rotate the [ENTER] knob to choose DELETE at the bottom of screen.
4. Press the [ENTER] knob twice to erase.
5. Press the [CLEAR] key to close the route list.

6. NAVIGATION

This chapter shows you how to get to a desired destination by using “quick points”, waypoints, port services and routes.

6.1 Navigating to Quick Points

The quick points feature allows you to navigate to a cursor-selected location. Each time a quick point is entered, the previous quick point is written over.

Navigating to a quick point

1. Operate the cursor pad to place the cursor at the location where you want to enter a quick point.
2. Press the [TLL/GOTO] key to show the GO TO window.

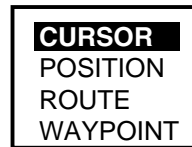

GO TO window

3. Rotate the [ENTER] knob to choose CURSOR and then push the [ENTER] knob.

A line connects between own ship and destination, marked “DEST,” and it shows the shortest course to the destination. The destination is marked with a flag.

Also, range and bearing from own ship to the destination appear in the data window. This location is saved to the WAYPOINT LIST as waypoint “DEST.”

FIX → □ DEST	
34° 35. 897N 135° 16. 763E	
DST	BRG
3.29nm	202° M

Quick point data window

You can also set the quick point by manually entering the longitude and latitude of the point. Choose POSITION at step 3 to do this.

To cancel the navigation, locate the cursor on the quick waypoint and then press the STOP soft key.

Navigating a quick route

1. Press the cursor pad to place the cursor at the position where you want to enter a waypoint.
2. Press the [ROUTE] key to show the new waypoint window.
3. If necessary, arrange the waypoint data.
4. Press the SAVE soft key.
5. Repeat steps 1 through 4 to complete the route.

Maximum 35 points can be entered. To erase a waypoint, place the cursor on the waypoint which you want to erase and then press the DELETE soft key.

6. Press the cursor pad to place the cursor on the first quick point of the route.
7. Press the [TLL/GOTO] key.

A line connects between own ship and the all quick points. The line shows the shortest course between quick points. Arrows on the line show the direction to follow the route. Range and bearing from own ship to the first destination appears in the data window.

To stop the navigation, place the cursor on the current destination and then press the STOP soft key.

Note: You can continue to add the quick point up to 35 points. If you want to create a new quick route, place the cursor on a leg in the route and then press the RELEASE soft key.

Navigating to ports, port service

C-MAP NT+™ chart cards have a port service list which shows services available at ports and harbors. You can use the list to set destination as follows.

1. Press the [MENU] key to show the menu bar.
2. Rotate the [ENTER] knob to choose FIND and then push the [ENTER] knob.
3. Rotate the [ENTER] knob to choose PORT SERVICES or PORT and then push the [ENTER] knob to show the appropriate window.



Port service window



Port window

4. Do one of the following depending on selection made at step 3.

PORT SERVICES

Select service mark desired with the [ENTER] knob, and then push the [ENTER] knob. Then, the display shows the location of those services.

The appropriate port names are shown in order of distance from own ship.

Rotate the [ENTER] knob to choose the port desired and push the [ENTER] knob twice. The service marks of the selected port appear. If you are okay to set this port as destination, press the [ENTER] knob to close the window. Confirm that the cursor is located on the selected port, and then press the [TLL/GOTO] key. Choose CURSOR and then push the ENTER knob.



Sample filling station, service marks

PORT

Press the cursor pad (▲▼) to choose port and then press the [ENTER] knob. Press the [ENTER] knob three times. Press the [TLL/GOTO] key, choose CURSOR and then push the [ENTER] knob.

6.2 Navigating to Waypoints

You can select an existing waypoint as destination by cursor, by name or through the WAYPOINT LIST.

To cancel the navigation, locate the cursor on the destination waypoint, and then press the STOP soft key.

Selecting waypoint by cursor

1. Press the cursor pad to place the cursor on the waypoint which you want to set as destination.
2. Press the [TLL/GOTO] key.
A line runs between waypoint selected and own ship's position. Also, range and bearing from own ship's position to waypoint appear in the data window.

Selecting waypoint by name

1. Press the cursor pad to place the cursor at a location not occupied by waypoint.
2. Press the [TLL/GOTO] key to show the GOTO window.

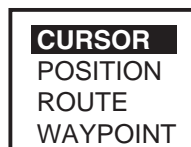

GOTO window

3. Rotate the [ENTER] knob to choose WAYPOINT and then push the [ENTER] knob.

The SELECT NAME window appears.

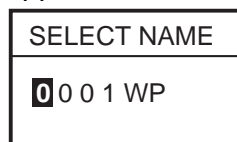

SELECT NAME window (for waypoints)

4. Enter the waypoint name you want to set as destination.
5. Press the SAVE soft key.

Selecting waypoint through WAYPOINT LIST

1. Press the [MENU] key to show the menu bar.
2. Rotate the [ENTER] knob to choose PLOTTER and then push the [ENTER] knob.
3. Rotate the [ENTER] knob to choose WAYPOINTS and then push the [ENTER] knob to show the WAYPOINT LIST.
4. Press the cursor pad (▲▼) to choose the waypoint which you want to set as destination.
5. Press the [TLL/GOTO] key.

6.3 Following a Route

You can follow a route as follows.

Setting a complete route as destination

This method enables you to navigate from the first waypoint of a route.

1. Press the cursor pad to place the cursor at the location not occupied by waypoint.
2. Press the [TLL/GOTO] key to show the GO TO window.
3. Rotate the [ENTER] knob to choose ROUTE and then push the [ENTER] knob to show the SELECT ROUTE window.

SELECT ROUTE	
ROUTE NAME	
1	0001RT
2	0002RT
3	0003RT
4	_____
5	_____
6	_____
7	_____
8	_____
9	_____
10	_____

Select route window

4. Rotate the [ENTER] knob to choose a route which you want to set as destination.
5. Push the [ENTER] knob.

Setting part of a route as destination

You can start the route navigation from any waypoint in a route.

1. Open the route list.
2. Press the cursor pad (▲▼) to choose the route desired.
3. Rotate the [ENTER] knob to choose PLOT at the bottom of the screen, and then push the [ENTER] knob.

The plotter display appears.

4. Press the cursor pad to place the cursor on any waypoint which is part of the route you want to set as destination.
5. Press the [TLL/GOTO] key.

A line runs between destination selected and own ship's position. Also, range and bearing from own ship's position to destination appear in the data window.

You can change the destination in the route by pressing the PREV or NEXT soft key.

Skipping route waypoints

In some instances you may want to “skip” waypoints while following a route. In the figure below, for example, the vessel has decided to navigate from waypoint 05 to 03, skipping waypoint 04.

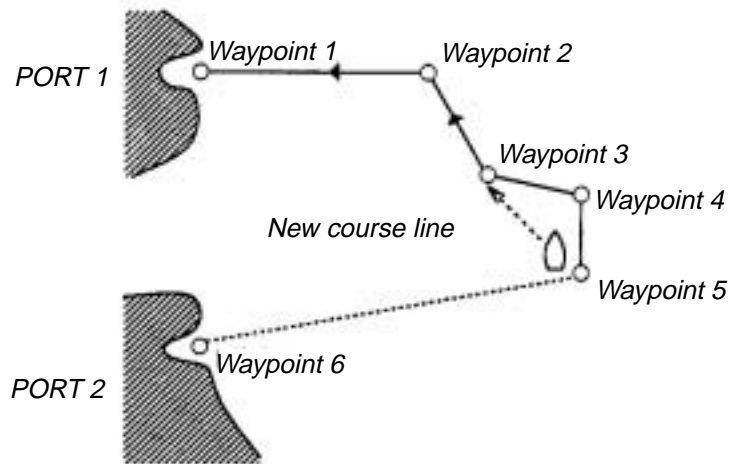

1. Press the cursor pad to place the cursor on a waypoint which is part of the route.
2. Press the ROUTE LIST soft key to show the route list.
3. Press the cursor pad to choose a route.
4. Rotate the [ENTER] knob to choose EDIT at the bottom of screen and then push the [ENTER] knob.
The route menu appears.
5. Press the cursor pad (▲▼) to choose the waypoint you want to skip.
6. Press the SKIP soft key.
7. Press the SAVE soft key to close the route menu.
8. Press the [CLEAR] key to close the route list.

6.4 Canceling Navigation

1. Press the [TLL/GOTO] key.
The confirmation window appears.



2. Confirm that “STOP” is selected, and then push the [ENTER] knob.
The navigation is cancelled.

7. ALARMS

The plotter section has seven conditions which generate both audio and visual alarms: arrival, XTE, temperature, depth, anchor, STW and grounding alarms. When an alarm is violated both audio and visual alarms are released. You may silence the audio alarm with the [CLEAR] key. The visual alarm remains on the screen until the offending alarm is deactivated or the reason for the alarm has disappeared.

You may set up the alarms on the ALARM menu.

6. Press the [MENU] key to show the menu bar.

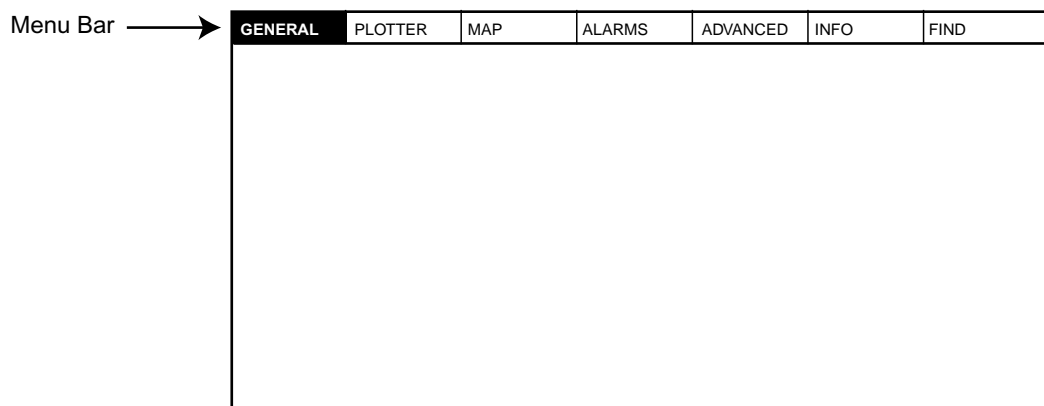

Menu bar

7. Rotate the [ENTER] knob to choose ALARMS and then push the [ENTER] knob to show the ALARMS menu.

AUDIBLE ALARM	Off
ARRIVAL ALARM	Off
XTE ALARM	Off
TEMPERATURE ALARM	Off
DEPTH ALARM	Off
ANCHOR ALARM	Off
STW ALARM	Off
GROUNDING ALARM	Off
GROUNDING ALARM RANGE	0.25 nm
GROUNDING ALARM REPORT	
FISH ALARM	Off
FISH ALARM (B/L)	Off

Alarms menu

7.1 Audible Alarm On/Off

Audio and visual alarms are released whenever an alarm setting is violated. You can enable or disable the audio alarm as follows:

1. Press the [MENU] key to show the menu bar.
2. Rotate the [ENTER] knob to choose ALARMS and then push the [ENTER] knob to show the ALARMS menu.
3. Rotate the [ENTER] knob to choose AUDIBLE ALARM and then push the [ENTER] knob.



4. Rotate the [ENTER] knob to choose Internal, Internal + External or Off as appropriate.
5. Push the [ENTER] knob.
6. Press the [MENU] key to close the menu.

7.2 Arrival Alarm

The arrival alarm informs you that your boat is approaching a destination waypoint. The area that defines an arrival zone is that of an imaginary circle which you approach from the outside of it. The alarm will be released if your boat enters the imaginary circle. Note that this alarm is available only when a destination is set.

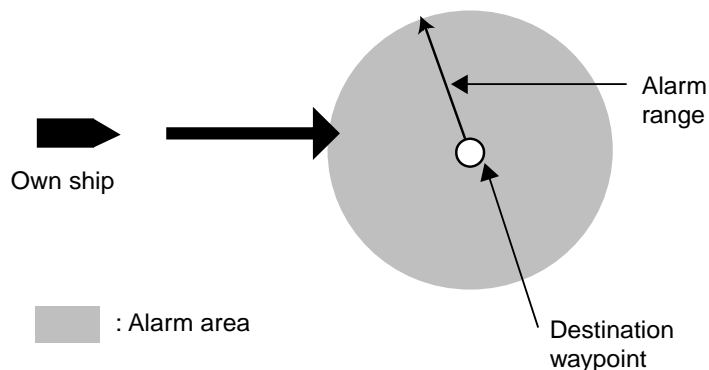

How the arrival alarm works

1. Open the ALARMS menu.
2. Rotate the [ENTER] knob to choose ARRIVAL ALARM and then push the [ENTER] knob.



3. Rotate the [ENTER] knob to choose the "x.xx (value) nm" and then push the [ENTER] knob.
4. Use the cursor pad to choose digit and rotate the [ENTER] knob to enter value.
5. Press the SAVE soft key and [MENU] key in order to close the menu.

7.3 XTE (Cross-Track Error) Alarm

The XTE alarm warns you when your boat is off its intended course. Note that this alarm is available only when a destination is set.

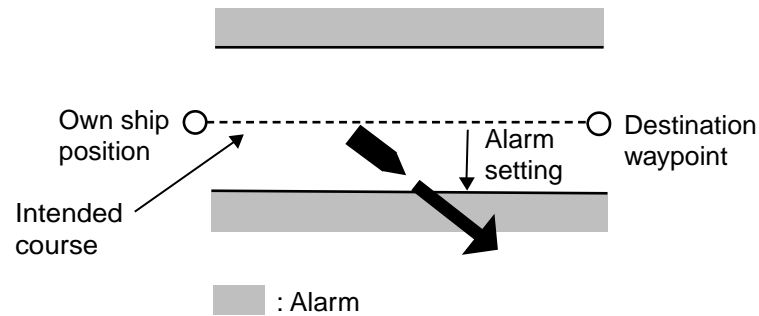

How to XTE alarm works

1. Open the ALARMS menu.
2. Rotate the [ENTER] knob to choose XTE ALARM and then push the [ENTER] knob.

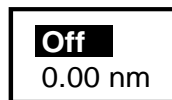

3. Rotate the [ENTER] knob to choose "x.xx (value) nm" and then push the [ENTER] knob.
4. Rotate the [ENTER] knob to enter value.
To change the digit, press the cursor pad (◀▶).
5. Press the SAVE soft key and [MENU] key in order to close the menu.

7.4 Temperature Alarm

Note: This alarm requires water temperature data.

There are two types of water alarms: Within Range and Out of Range. The Within Range alarm sounds when the water temperature is within the range set, and the Out of Range sounds when the water temperature is higher or lower than the range set.

1. Open the ALARMS menu.
2. Rotate the [ENTER] knob to choose TEMPERATURE ALARM and then push the [ENTER] knob.

Off
Max +32.00 F
Min +32.00 F

3. Confirm that the cursor is at the top line, and then push the [ENTER] knob.

Off
Within Range
Out of Range

4. Rotate the [ENTER] knob to choose Within Range or Out of Range as appropriate and then push the [ENTER] knob.
5. Rotate the [ENTER] knob to choose Max and then push the [ENTER] knob.
6. Enter the value for the maximum temperature and then press the SAVE soft key.
7. Rotate the [ENTER] knob to choose Min, and then push the [ENTER] knob.
8. Enter the value for Min.
For Min, you can switch between plus and minus by rotating the [ENTER] knob.
9. Press the SAVE soft key and [MENU] key in order to close the menu.

7.5 Anchor Alarm

The anchor alarm informs you that your boat is moving when it should be at rest.

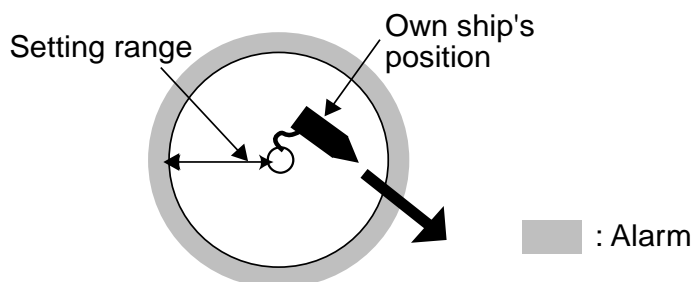

How the anchor watch alarm works

1. Open the ALARMS menu.
2. Rotate the [ENTER] knob to choose ANCHOR ALARM and push the [ENTER] knob.



3. Rotate the [ENTER] knob to choose "x.xx (value) nm" and then push the [ENTER] knob.
4. Rotate the [ENTER] knob to enter the value.
5. Push the SAVE soft key and [MENU] key in order to close the menu.

7.6 STW Alarm

The STW alarm warns you when your boat's speed is over the speed range set.

1. Open the ALARMS menu.
2. Rotate the [ENTER] knob to choose STW ALARMS and then push the [ENTER] knob.

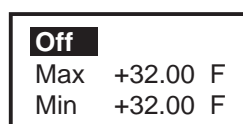

3. Confirm that the cursor is located at the top line and then push the [ENTER] knob.
4. Rotate the [ENTER] knob to choose On and then push the [ENTER] knob.
5. Rotate the [ENTER] knob to choose Max, and then push the [ENTER] knob.
6. Rotate the [ENTER] knob to enter the value, and then press the SAVE soft key.
7. Rotate the [ENTER] knob to choose Min, and then push the [ENTER] knob.
8. Enter the value for Min, similar to how you did for Max.
9. Press the SAVE soft key and [MENU] key in order to close the menu.

7.7 Depth Alarm

Note: This alarm requires depth data.

The depth alarm sounds when the depth is within the alarm range set.

1. Open the ALARMS menu.
2. Rotate the [ENTER] knob to choose DEPTH ALARM and then push the [ENTER] knob.

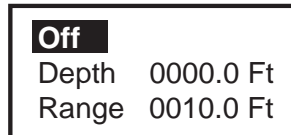

3. Confirm that the cursor is located at the top line, and then push the [ENTER] knob.



4. Rotate the [ENTER] knob to choose On and then push the [ENTER] knob.
5. Rotate the [ENTER] knob to choose Depth and then push the [ENTER] knob.
6. Enter the starting point of range and then press the SAVE soft key.
7. Rotate the [ENTER] knob to choose Range and then push the [ENTER] knob.
8. Enter the alarm range, and then press the SAVE soft key.
9. Press the [MENU] key to close the menu.

7.8 Grounding Alarm

The grounding alarm sounds when there is an object on chart data which is within the range and depth set. Further, you can know what kind of object is causing the alarm when it enters in the range.

1. Open the ALARMS menu.
2. Rotate the [ENTER] knob to choose GROUNDING ALARM and then push the [ENTER] knob.
3. Rotate the [ENTER] knob to choose “xx (value) ft” and then push the [ENTER] knob.
4. Enter the depth value desired.
5. Press the SAVE soft key.
6. Press the [CLEAR] key.
7. Rotate the [ENTER] knob to choose GROUNDING ALARM RANGE and then push the [ENTER] knob.

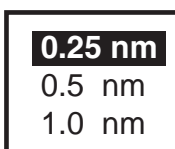

8. Rotate the [ENTER] knob to choose the range and then push the [ENTER] knob.
9. Push the [MENU] key to close the menu.

When the grounding alarm warns, you can know what kind of object has entered the setting range and depth by choosing GROUNDING ALARM REPORT from the ALARMS menu.

7. ALARM

This page is intentionally left blank.

8. CUSTOMIZING YOUR UNIT

This chapter describes the various options which allow you to customize the plotter section to suit your needs.

8.1 GENERAL Menu

The GENERAL menu provides the basic setup for the unit.

LANGUAGE	English
KEYPAD BEEP	Off
PALETTE	Normal
TIME LINE	Infinite
TIME REFERENCE	UTC
TIME FORMAT	12 hour
DATE FORMAT	MM-DD-YY
AUTO INFO	On Points
SHIP ICON	
WIND GRAPH	
UNITS OF MEASURE	

General menu

LANGUAGE

You can choose the language to display from among English, Italian, French, German, Spanish, Norwegian and Swedish.

KEYPAD BEEP

Turns key beep on/off.

PALETTE

The display hue can be matched to the current lighting condition from among SunLight, Night, Normal and NOAA (NOAA-like colors).

TIME LINE

Choose the interval for the time line (own ship's vector) from among 2 min, 10 min, 30 min, 1 hour, 2 hours and Infinite. The length of the bar shows distance your ship will move within selected time. Also the line can be erased by selecting Off.

TIME REFERENCE

GPS uses UTC time. If you would rather use local time, key in the time difference between it and UTC time. Rotate the [ENTER] knob to change the digits and "+" "-".

TIME FORMAT

Chooses time notation; 12 hours or 24 hours.

8. CUSTOMIZING YOUR UNIT

DATE FORMAT

Chooses date notation; MM-DD-YY or DD-MM-YY.

AUTO INFO

Chooses what data is available with the cursor; Off, On Points or On All.

On Points: Data for selected chart symbol, for example, lighthouse or harbor.

All Points: Data for any location within the area covered by the chart.

SHIP ICON

Chooses the shape of own ship marker; ●, ⊕ or ▲.

WIND GRAPH

See section 2.10 for details about the wind display.

UNITS OF MEASURE

Chooses unit of measurement for distance, speed, depth, altitude and temperature.

Distance: nm, sm, km, nm + ft, nm + m, sm + ft
(For "+ft" and "+m," it is used in the near range.)

Speed: Kt, mph, km/h

Depth: ft, fa, m, pb

Altitude: ft, fl, m

Temperature: C, F

8.2 MAP Menu

The MAP menu sets up the map display.

ZOOM TYPE	Standard
FONTS & SYMBOLS	NORMAL
PERSPECTIVE VIEW	Off
DYNAMIC NAV-AIDS	Off
MIXING LEVELS	On
SAFETY STATUS BAR	Off
NAV AIDS PRESENTATION	US
CURRENTS PREDICTION	
MAP CONFIGURATIONS	

Map menu

ZOOM TYPE

Chooses the zoom type between Standard and Flexi-Zoom.

Standard: Normal zoom function

Flexi-Zoom: Shows the scale indication.

FONTS & SYMBOLS

Chooses the size of landmarks and their names, between NORMAL and LARGE.

PERSPECTIVE VIEW

Chart data is projected in perspective mode, for 3D simulation, during navigation.

DYNAMIC NAV-AIDS

Shows the flash from the lighthouse/buoy with the actual interval.

MIXING LEVELS

Detailed chart data and coarse chart data may be incorporated and displayed in areas where they are mixed. With detailed chart data displayed and own ship position or cursor position as reference, coarse chart data area of low accuracy is shown in white when this setting is disabled. When enabled, coarse chart data is shown in the same scale as detailed chart data and its location is marked with a dots.

SAFETY STATUS BAR

When this item is turned On, the following menu bar appears at the top of screen.

NORMAL	BEST MAP	DATA OFF	DECLUT.	DANGERS	CAUTIONS
--------	----------	----------	---------	---------	----------

NORMAL (or U.ZOOM or O.ZOOM)

This indication appears to help you select a suitable chart scale.

NORMAL: Suitable chart scale is selected.

U.ZOOM: Chart scale is too small.

O.ZOOM: Chart scale is too large.

BEST MAP

Shown in red when the unsuitable chart scale is selected.

DATA OFF

Mixing levels can be turned on when the electronics chart coverage area does not provide enough coverage to completely fill the display screen.

When the cursor or own ship mark is placed in the area with coverage, the chart data is shown as below.

On: The chart line in the area with no coverage is shown. This area is filled with dots.

Off: The area with no coverage is not shown (goes to white).

DECLUT.

For C-MAP MAX charts, symbols of low priority (ex. map symbols on land) can be automatically hidden to unclutter the screen when you change the scale.

When the function is turned on, DECLUT. appears in red.

DANGERS

Shown in red when the GROUNDING alarm detects the high-risk object (listed in the grounding report) when the GROUNDING alarm is turned on.

CAUTIONS

Shown in red when the GROUNDING alarm detects the low-risk object when the GROUNDING alarm is turned on.

NAV AIDS PRESENTATION

Chooses what kind of nav aids symbols to display, International or US.

CURRENTS PREDICTION

Displays the current prediction window, which shows the direction and speed of the current at the place of current symbol (arrow shaped) selected with cursor.

CURRENTS PREDICTION	
Apr/25/05	10:05:26AM
DIR - - -T	SPD -.- -kt

Current prediction window

This window can show the past and future current data in by pressing INCR. TIME or DECR. TIME soft key. Each press of those keys shows the past (or future) current data in 30 minutes intervals. Current data for the desired date and time is also available by using the SET TIME soft key. Note that current symbols change their shapes and orientations to show the current direction depending on the time set in the window when the cursor is not placed on the current mark. (DIR and SPD data in the window are blank.)

To erase the current prediction window, press the EXIT soft key.

MAP CONFIGURATION**DISPLAY MODE**

Chooses the map to display; Full, Medium, Low, Tides or Custom.

“Full” shows all data in the chart card. Note that data can be arranged only when Custom is chosen here. As for each items, refer to the handbook for C-MAP.

Settings of Display modes

Partition	Items	Display mode			
		Full	Medium	Low	Tides
MARINE SETTINGS	NAMES	On	On	On	On
	BUOYS ID	On	Off	Off	Off
	NAV AIDS	On	On	On	Off
	LIGHT SECTORS	On	Off	Off	Off
	ATTENTION AREAS	On	On	Off	Off
	TIDES & CURRENTS	On	Off	Off	On
	SEABED TYPE	On	Off	Off	Off
	PORTS & SERVICES	On	On	Off	Off
	TRACK & ROUTES	On	Off	Off	Off
	UNDERWATER OBJECTS	On	On	Off	Off
DEPTH SETTINGS	DEPTH RANGE	On	On	Off	Off
	DEPTH RANGE MIN	0	0	0	0
	DEPTH RANGE MAX	32805	16	16	16
	ROCKS MIN	0	0	0	0
	ROCKS MAX	32805	16	16	16
LAND SETTINGS	LAND ELEVATION VALUES	On	Off	Off	Off
	ROADS	On	Off	Off	Off
	POINTS OF INTEREST	On	Off	Off	Off
CHART SETTINGS	LAT/LON GRID	On	Off	Off	Off
	CHART BOUNDARIES	On	Auto	Off	Off
	VALUE ADDED DATA	On	Off	Off	Off

8. CUSTOMIZING YOUR UNIT

Setting details

DEPTH SETTINGS

Item	Settings
DEPTH RANGE	On, Off
DEPTH RANGE MIN	0-49211 ft
DEPTH RANGE MAX	0-49212 ft
ROCKS MIN	0-32804 ft
ROCKS MAX	0-32805 ft

LAND SETTINGS

Item	Settings
LAND ELEVATION VALUES	On, Off
ROADS	On, Off
POINTS OF INTEREST	On, Off

CHART SETTINGS

Item	Settings
LAT/LON GRID	On, Off
CHART BOUNDARIES	On, Off, Auto
VALUE-ADDED DATA	On, Off

MARINE SETTINGS

Item	Settings
NAMES	On, Off
BOUYS ID	On, Off
NAV AIDS	On, Off
LIGHT SECTORS	On, Off
ATTENTION AREAS	On, Off
TIDES & CURRENTS	On, Off
SEABED TYPE	On, Off
PORTS & SERVICES	On, Off
TRACKS & ROUTES	On, Off
UNDERWATER OBJECTS	On, Off

8.3 ADVANCED Menu

The ADVANCED menu calibrates data.

FIX

Item	Settings
FIX CORRECTION	GPS-generated position may be off by some seconds because of various factors. In this case, you can automatically correct GPS position by selecting On.
COMPUTE CORRECTION	Corrects the GPS antenna position. After placing the cursor at the own ship's true position, select this item.
CORRECTION OFFSET	Corrects the GPS antenna position manually. Enter the longitude and latitude numeric data of own ship's true position.
POSITION FILTER	When the DOP or receiving condition is unfavorable, the GPS fix may change, even if the vessel is dead in water. This change can be reduced by smoothing the raw GPS fixes. You can choose the setting from among Off, Low, Medium and High. The higher the setting, the more smoothed the raw data, however too high a setting slows response time to change in latitude and longitude. This is especially noticeable at high ship's speeds. Off is normal setting; increase the setting if the GPS fix changes.
SPEED FILTER	During position fixing, ship's velocity (speed) is directly measured by receiving GPS satellite signals. The raw velocity data may change randomly depending on receiving conditions and other factors. You can reduce this random variation by increasing the filter setting. Like with latitude and longitude filter, the higher the speed filter the more smoothed the raw data. If the setting is too high, however, the response to speed and course change slows. For no smoothing, choose Off. (Off, Low, Medium, High)

NAVIGATE

Item	Settings
COORDINATE SYSTEM	Choose the coordinate display method among ddd mm ss, ddd mm.mm, ddd mm.mmm and ddd.ddddd for latitude, or TD.
MAP DATUM	Geodetic datum is a reference for geodetic survey measurements consisting of fixed latitude, longitude and azimuth values associated with a defined station of reference. You must have the correct geodetic datum selected in your plotter so that it will reference the correct point on the chart for a given latitude and longitude. Although WGS-84 is now the world standard, other categories of charts still exist.
MAP ORIENTATION	North Up, Course Up, Auto Course Up
MAP ORIENTATION RES	Choose the resolution angle for the map orientation. (Setting range: 5° to 60°)

COMPASS

Item	Settings
BEARINGS	Choose how to calculate bearing, Mag or True. True bearing is a bearing measured using true North as the reference direction, and it is calculated by the formula True Bearing = Magnetic Bearing -Magnetic Variation. Magnetic bearings are measured with magnetic north as the reference direction. Select Mag when using a magnetic compass, True when using a gyrocompass.
VARIATION	The location of the magnetic north pole is different from the geographical north pole. This causes a difference between the true and magnetic north location. This difference is called magnetic variation, and varies with respect to the observation point on earth. Your unit is preprogrammed with all the earth's magnetic variations. However, you may wish to enter variation manually to refine accuracy by entering the magnetic variation referring to a nautical chart.
CALIBRATION	Offsets latitude/longitude position to further refine position accuracy. This table is used to match magnetic value on the plotter with the readout of compass.

8.4 INFO Menu

This menu shows the detailed information for the location selected by the cursor. Choose a location, and then open the INFO menu and select item.

8.5 FIND Menu

You can find objects on the chart data in use dividing with the category of TIDE STATION, WRECKS and OBSTRUCTIONS.

Choose the appropriate category from the FIND menu, and then push the [ENTER] knob.

8. CUSTOMIZING YOUR UNIT

This page is intentionally left blank.

9. DATA TRANSFER

This chapter provides information for saving and replaying data to and from memory cards, and updating and downloading data.

9.1 Memory Card Operations

The memory cards store these data: waypoints, routes and track.

9.1.1 Selecting the card slot to use

There are two card slots, upper and lower. Choose the one to use for memory cards as follows:

1. Press the [MENU] key to show the menu bar.
2. Rotate the [ENTER] knob to choose PLOTTER and then push the [ENTER] knob.

TRACK
ROUTES
WAYPOINTS
MEMORY CARD

Plotter menu

3. Rotate the [ENTER] knob to choose MEMORY CARD and then push the [ENTER] knob.

The MEMORY CARD list appears.

Currently selected slot

MEMORY CARD				
	NAME	TYPE	DATE	TIME
SLOT 1				
FILE 1				
WPTS 7				
QWPTS 0				
RTES 2				
TRKS 0				
SAVE	LOAD	DELETE	INITIALIZE	CHANGE

Memory card list

4. Rotate the [ENTER] knob to choose CHANGE at the bottom of screen and then push the [ENTER] knob to change the active slot.

The currently selected slot is shown at the left-hand top corner.

SLOT 1: Upper slot

SLOT 2: Lower slot

9.1.2 Formatting memory cards

Before you can use a memory card it must be formatted. This prepares the card for use with the system. Note that formatting a memory card erases all data from the card.

1. Insert the memory card to the selected slot.
2. Open the MEMORY CARD LIST.
3. Rotate the [ENTER] knob to choose INITIALIZE at the bottom of screen and then push the [ENTER] knob.

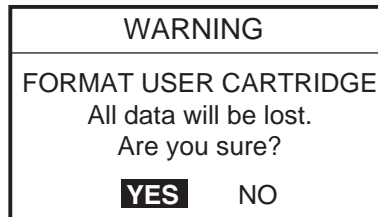

4. Push the [ENTER] knob to format the card.

Note: If the memory card was not inserted correctly, the message "FILE NOT FOUND." appears.

9.1.3 Saving data to a memory card

1. Insert a formatted memory card into the selected slot.
2. Press the [MENU] key to show the menu bar.
3. Rotate the [ENTER] knob to choose PLOTTER and then push the [ENTER] knob to show the PLOTTER menu.
4. Rotate the [ENTER] knob to choose MEMORY CARD and then push the [ENTER] knob to show the MEMORY CARD list.
5. Rotate the [ENTER] knob to choose SAVE and then push the [ENTER] knob.

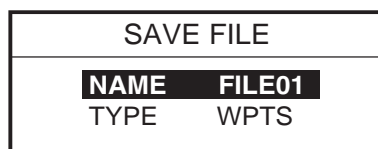

6. Press the [ENTER] knob, and then enter the file name for which you want to save the data under.
7. Rotate the [ENTER] knob and then push the [ENTER] knob.



8. Rotate the [ENTER] knob to choose WPTS (waypoints), TRACK or ROUTE as appropriate.
9. Push the [ENTER] knob.
10. Press the SAVE soft key.

9.1.4 Playing back data from a memory card

Data (track, waypoints, routes) can be loaded from a memory card and displayed on the screen. This feature is useful for observing past data.

1. Insert the memory card to play back into the selected slot.
2. Open the MEMORY CARD list.
3. Rotate the [ENTER] knob to choose LOAD and then push the [ENTER] knob.

9.2 Uploading/Downloading Data

You can upload/download waypoints and routes from/to a PC or another GP-7000/F to the internal memory, through the NMEA1, NMEA 2 or RS-232C port at the rear of the display unit.

9.2.1 Uploading/downloading waypoints data

You may upload/download all waypoints data as follows.

1. Connect the PC or another GP-7000/F to the equipment.
2. Choose INPUT/OUTPUT from the ADVANCED menu.
3. Choose NMEA 1 OUTPUT, NMEA 2 OUTPUT or RS232 3 OUTPUT appropriately.

The sentence window appears.

GLL	On	WPL	On
VTG	On	RTE	On
BWR	Off	TLL Out	On
DBT	Off		
DPT	Off		
MTW	Off		
VHW	Off		
WCV	Off		
APA	Off		
APB	On		
HDG	Off		
BOD	Off		
XTE	Off		
RMA	Off		
RMB	On		
RMC	On		
GGA	Off		
HSC	Off		
AAM	Off		
GTD	Off		
MWV	Off		
ZDA	Off		

Sentences window

4. Choose WPL and then set it on.
5. Press the [CLEAR] key several times to close the window and menus.
6. Open the WAYPOINT LISTS.

9.3 Waypoint, Route Format

You may transfer waypoint and route data to another GP-7000 series unit or a PC in Standard or Furuno format, via the NMEA1 port, NMEA2 port or PC NMEA IN port.

1. Press the [MENU] key to show the menu bar.
2. Rotate the [ENTER] knob to choose ADVANCED from the menu bar and then push the [ENTER] knob.
3. Rotate the [ENTER] knob to choose INPUT/OUTPUT and then push the [ENTER] knob.
4. Rotate the [ENTER] knob to choose WPL/RTE FORMAT and then push the [ENTER] knob.





5. Choose Furuno or Standard as appropriate and then push the [ENTER] knob.
Standard: NMEA format WPL and RTE sentences are output when “SEND” is executed to transfer waypoint list or route list.
Furuno: Waypoint and route data in Furuno original format (P sentence) are output when “SEND” is executed to transfer waypoint list or route list. Waypoint color, shape and comment data are also sent.
6. Press the [MENU] key to close the menu.

10. MAINTENANCE & TROUBLESHOOTING

10.1 Maintenance

Regular maintenance is important for continued performance. Important points to be checked from time to time are shown below.



WARNING

Do not open the equipment.

Hazardous voltage which can cause electrical shock exists inside the equipment. Only qualified personnel should work inside the equipment.

Location	Check point	Remedy
Antenna unit	Check for loosened and corroded bolts.	Tighten loosened bolts. Replace heavily corroded bolts.
Antenna cable	Check connection point for watertightness.	Replace damaged parts.
	Check connector for tightness and corrosion.	
	Check cables for damage.	
Display unit connectors	Check for tight connection.	Tighten loosened connectors.
Ground terminal	Check for tight connection and corrosion.	Clean or replace as necessary.
Display unit	Dust and foreign material on the display unit.	Dust or dirt may be removed from the cabinet with soft cloth. Water-diluted mild detergent may be used if desired. DO NOT use chemical cleaners to clean the display unit; they may remove paint and markings. Wipe the LCD carefully to prevent scratching, using tissue paper and an LCD cleaner. To remove dirt or salt deposits, use an LCD cleaner, wiping slowly with tissue paper so as to dissolve the dirt or salt. Change paper frequently so the salt or dirt will not scratch the LCD.
Transducer	Check the transducer face for marine life, which can reduce sensitivity.	Remove marine life from the transducer when drydocking the boat. Use a piece of wood to remove any marine life.

10.2 Replacement of Fuse

 CAUTION
<p>Use the correct fuse.</p> <p>Use of a wrong fuse can cause fire or damage the equipment.</p>

The fuse on the power cable protects the system from reverse polarity of the ship's mains and equipment fault. If the fuse blows, find the cause before replacing it. Use only a 3A fuse. Using the wrong fuse will damage the unit and void the warranty.

Name	Type	Code No.
Fuse	FGBO-A 3A AC125V	000-549-063

10.3 Replacement of Battery

A battery installed on the circuit board inside the display unit preserves data when the power is turned off. The life of the battery is about three years. When the battery voltage is low the battery icon () appears on the display. When this happens, contact your dealer to request replacement of the battery.

Name	Type	Code No.
Battery	CR2477/1HF	000-150-460-10

Note: If you require data currently displayed, save it to a SD memory card before replacing the battery.

 WARNING
<p> Be sure the battery is inserted correctly.</p> <p>Wrong polarity may cause an explosion.</p>

10.4 Simple Troubleshooting

This section provides simple troubleshooting procedures which the user can follow to restore normal operation. If you cannot restore normal operation do not attempt to check inside the unit. Any trouble should be referred to a qualified technician.

General troubleshooting

If ...	Then ...
you cannot turn on the power	check for blown fuse.
	check that the power connector is firmly fastened.
	check for damaged power cable.
	check battery for proper voltage output.
	press the [POWER/BRILL] key a little harder.
no picture appears	press the [POWER/BRILL] key and then rotate the [ENTER] knob.
there is no response when a key is pressed	turn off and on the power.
the picture goes off suddenly*	press the [POWER/BRILL] key to turn the power on.

*: When turning off and on again the breaker, press the [POWER/BRILL] key to power on the equipment.

Plotter troubleshooting

If ...	Then ...
position is not fixed within 90 seconds	check that antenna connector is firmly fastened.
	check number of satellites received, on the GPS STATUS display.
position is wrong	enter position offset, on the ADVANCED menu.
the track is not plotted	check that On is selected at TRACK in the PLOTTER menu.
	check that On is selected at VISIBLE in the PLOTTER menu.
bearing is wrong	check the VARIATION in the ADVANCED menu.
the ship's speed indication is not zero after the ship is stopped	try to decrease SPEED FILTER in the ADVANCED menu.

10.5 Diagnostics

This section provides the procedures for testing the equipment for proper operation. Four tests are provided: RAM menu, Dim menu, Cartridges and Serial ports. To access the test menu, do the following:

1. Press the [POWER/BRILL] key to turn on the equipment while holding the [CLEAR] key down.
2. Release the [MENU] key when you hear the beep.

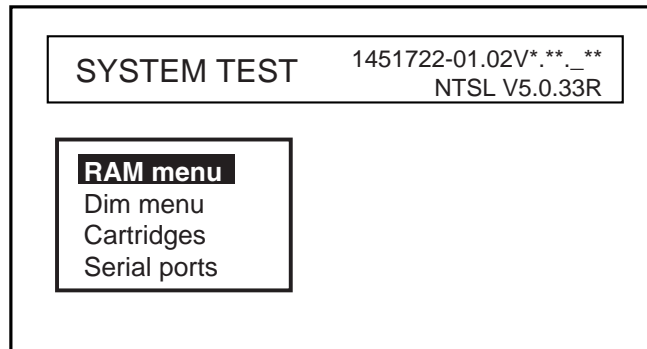

*: Program version No.

SYSTEM TEST menu

10.5.1 RAM menu

The RAM menu checks each memory circuit and signal main board. Results for device checks are shown as OK or NG (No Good). For any NG, request service.

1. Rotate the [ENTER] knob to choose “RAM menu” on the SYSTEM TEST.
2. Push the [ENTER] knob to show the RAM window.

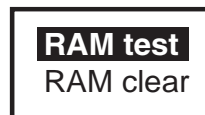

RAM window

3. Rotate the [ENTER] knob to select “RAM test” and then push the [ENTER] knob to start the RAM test.
4. Confirm that “OK” appears.

10.5.2 Dim menu

The Dim menu checks the contrast and backlight control circuits for proper operation.

1. Rotate the [ENTER] knob to choose “Dim menu” on the SYSTEM TEST.
2. Push the [ENTER] knob to show the Dim window.



Dim window

3. Rotate the [ENTER] knob to select “Contrast” or “Backlight” as appropriate, and then push the [ENTER] knob.
4. Press the cursor pad to change the setting.
5. Confirm that the contrast or backlight changes appropriately.

10.5.3 Cartridge

The Cartridge item checks internal chart data or the chart card data in use.

Checking the internal chart data

1. Rotate the [ENTER] knob to choose “Cartridge” on the SYSTEM TEST.
2. Push the [ENTER] knob to show the Cartridge window.

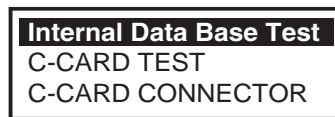

Cartridge window

3. Rotate the [ENTER] knob to choose “Internal Data Base Test” and then push the [ENTER] knob to start the test.
4. Confirm the test result.

Checking the chart card in use

1. Rotate the [ENTER] knob to choose “SD-CARD TEST” on the Cartridge window.
2. Push the [ENTER] knob to show the card test display.
3. Confirm the test result.

10.5.4 Serial ports

You can confirm the signal input.

1. Rotate the [ENTER] knob to choose Serial port from the SYSTEM TEST.
2. Push the [ENTER] knob to show the Serial port window.



Serial port

3. Rotate the [ENTER] knob to choose “Change parameters” and then push the [ENTER] knob.

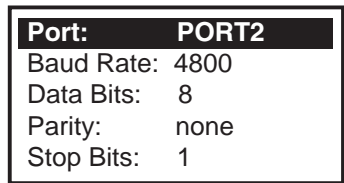

4. Enter the settings for the port in use and then push the [CLEAR] key.
5. Rotate the [ENTER] knob to choose “Input data display” and then push the [ENTER] knob.
6. Press the [CLEAR] key twice to finish.

Note: When choosing Input data display, the data input from the external equipment connected are shown.

10.6 Program No.

You can confirm the software program No by following procedure.

1. Rotate the [ENTER] knob to choose “ADVANCED”, and then push the [ENTER] knob.
2. Rotate the [ENTER] knob to choose “SYSTEM UPDATE”, and then push the [ENTER] knob to show the System update menu..

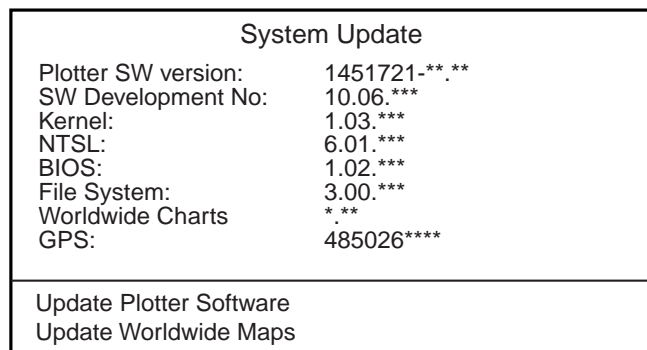

*: Program version No.

3. To escape from the System update menu, press the [MENU] key.

10.7 Clearing the Memory

The memory can be cleared to restart operation with default settings. All tracks, waypoints and routes are deleted and all default menu settings are restored.

1. Turn the power on while holding the [MENU] key down.
2. Release the [MENU] key when you hear the beep.
3. Rotate the [ENTER] knob to choose “RAM menu” and then push the [ENTER] knob.

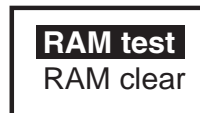

RAM window

4. Rotate the [ENTER] knob to choose “RAM clear” and then push the [ENTER] knob.

The message “Are you sure?” appears.

5. Push the [ENTER] knob to clean the memory.

The equipment restarts automatically.

10.8 GPS Cold Start

Cold start clears the Almanac (stored in the memory) to receive the latest Almanac from the GPS satellites. When the equipment has not been used for a long time (over one year), execute cold start as shown below to receive the latest Almanac.

1. Choose ADVANCED from the menu bar, and then push the [ENTER] knob to show the ADVANCED menu.
2. Rotate the [ENTER] knob to choose INPUT/OUTPUT, and then push the [ENTER] knob.
3. Rotate the [ENTER] knob to choose INTERNAL GPS SETUP and then push the [ENTER] knob.



Internal GPS setup window

4. Rotate the [ENTER] knob to choose RESTART GPS.
5. Push the [ENTER] knob to restart.

10. MAINTENANCE & TROUBLESHOOTING

This page is intentionally left blank.

APPENDIX

Menu Tree

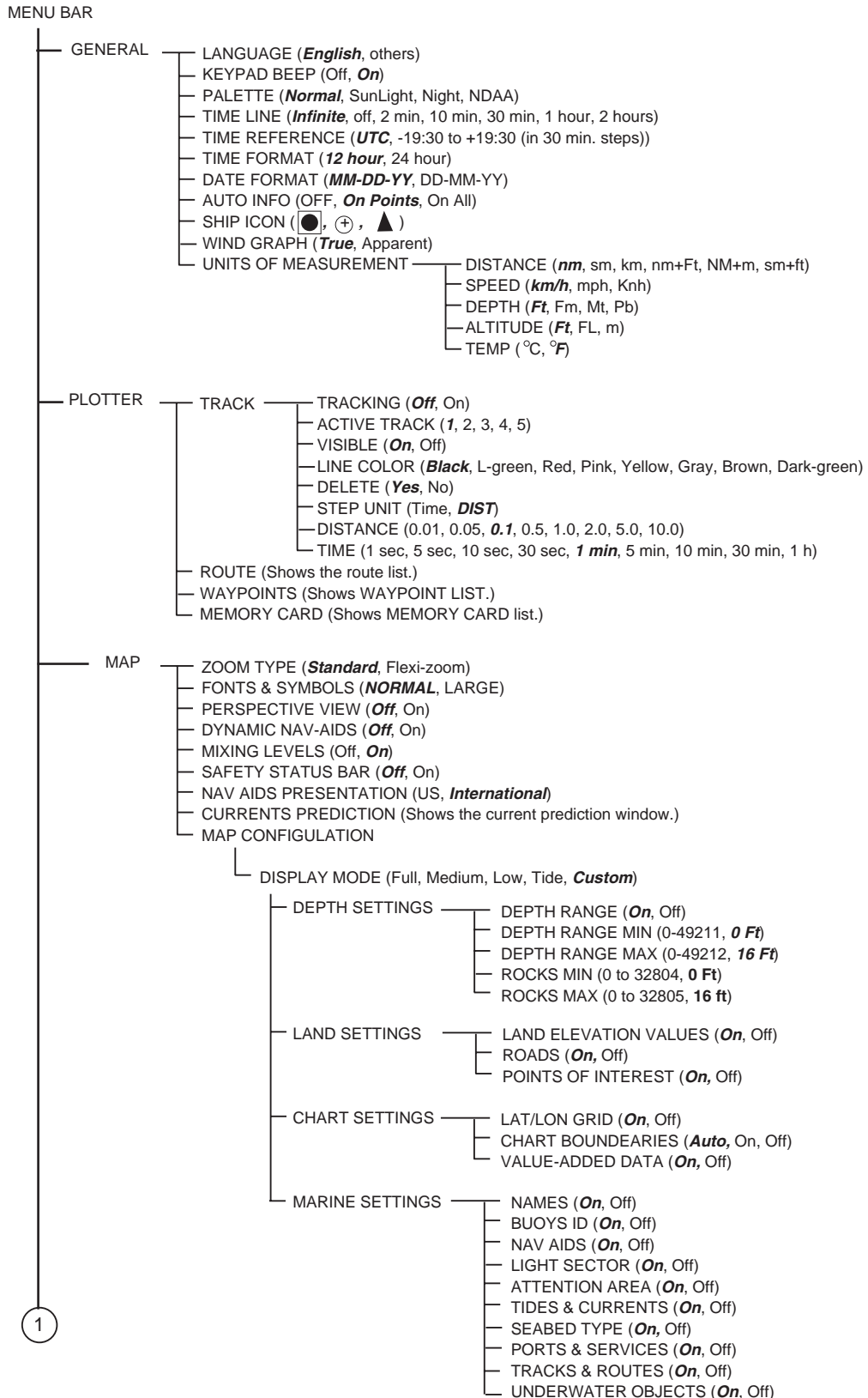

1

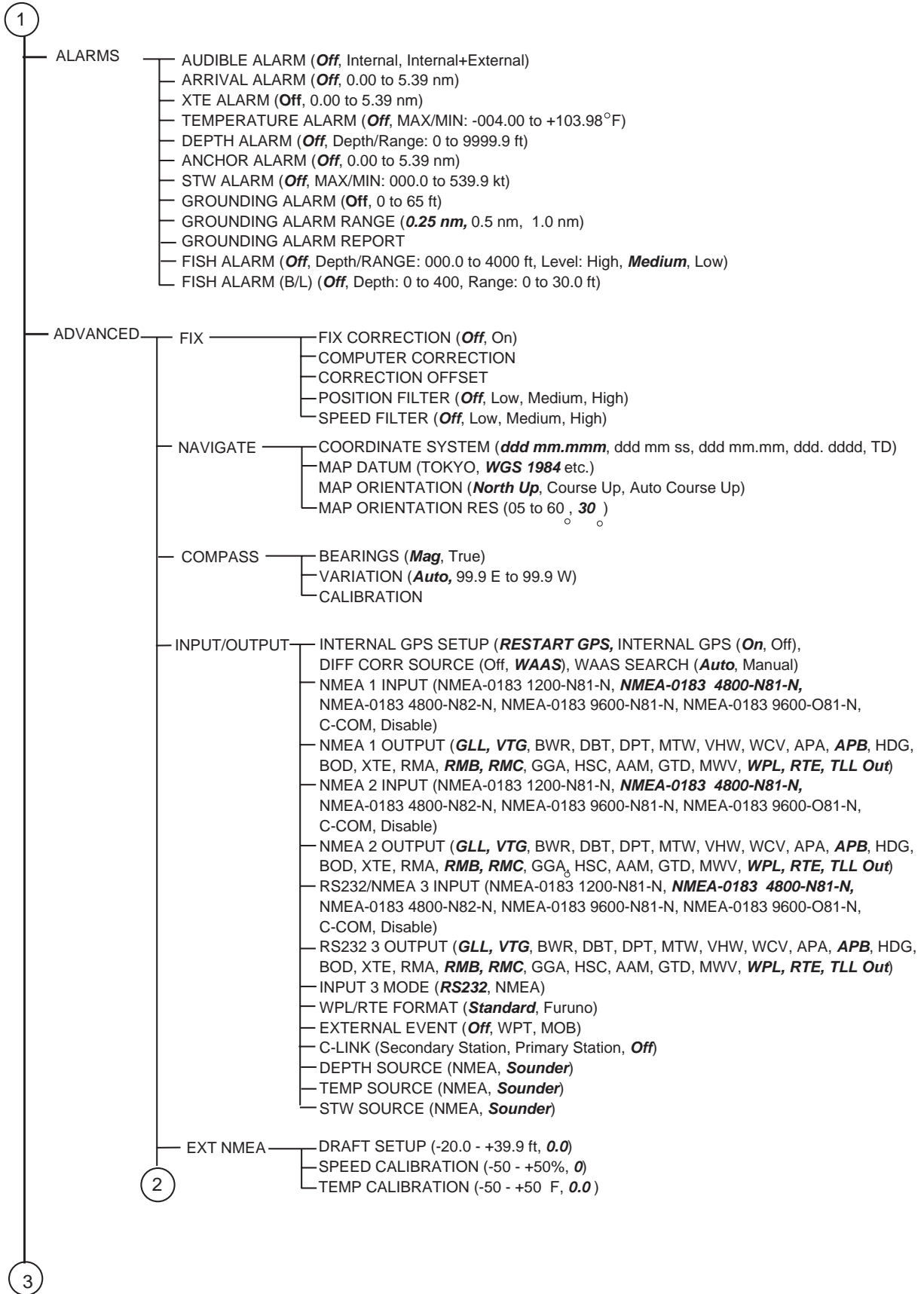

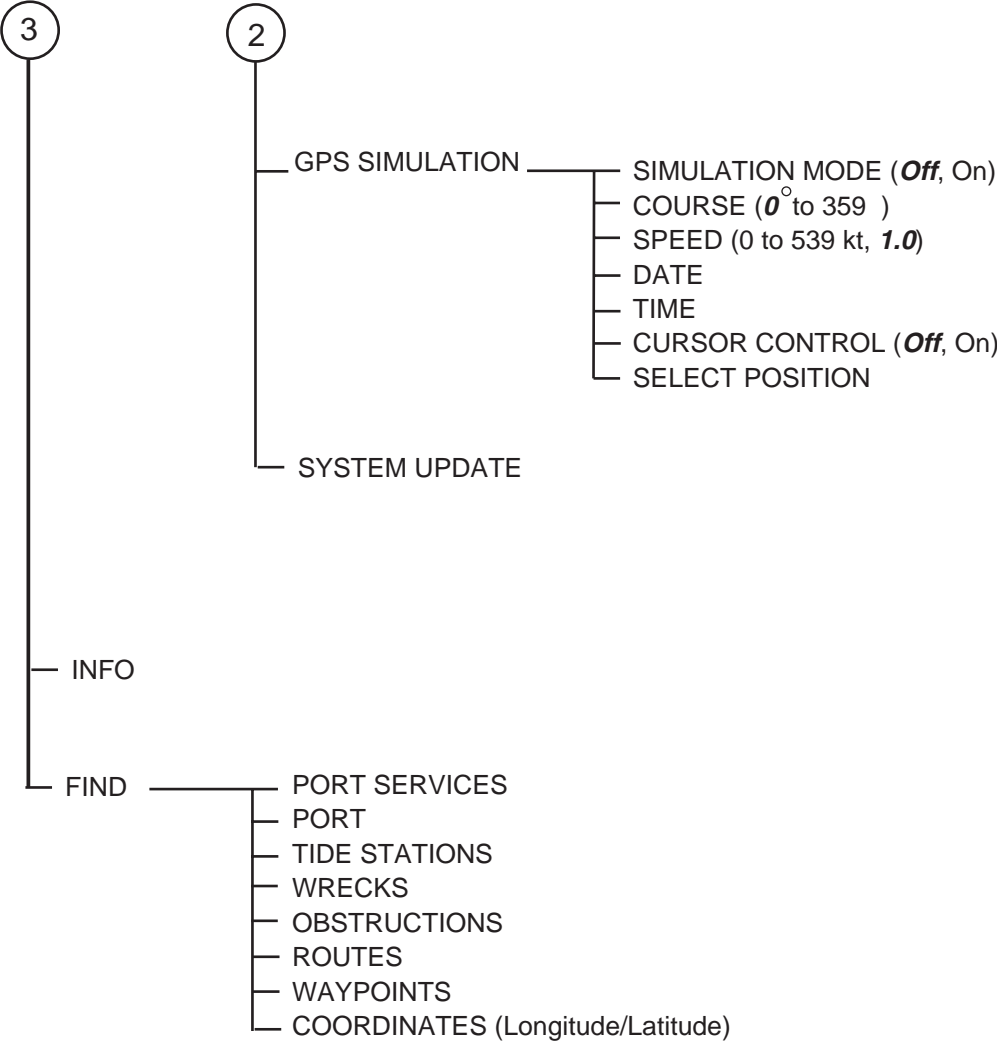

What is WAAS?

WAAS, available in North America, is a provider in the worldwide SBAS (Satellite Based Augmentation System) navigation system. An SBAS provider furnishes GPS signal corrections to SBAS users. Two more SBAS providers are also currently under development, MSAS (Multi-Functional Satellite Augmentation System) for Japan and EGNOS (Euro Geostationary Navigation Overlay Service) for Europe. All providers will be compatible with one another, thus providing “seamless” position fixes to SBAS users.

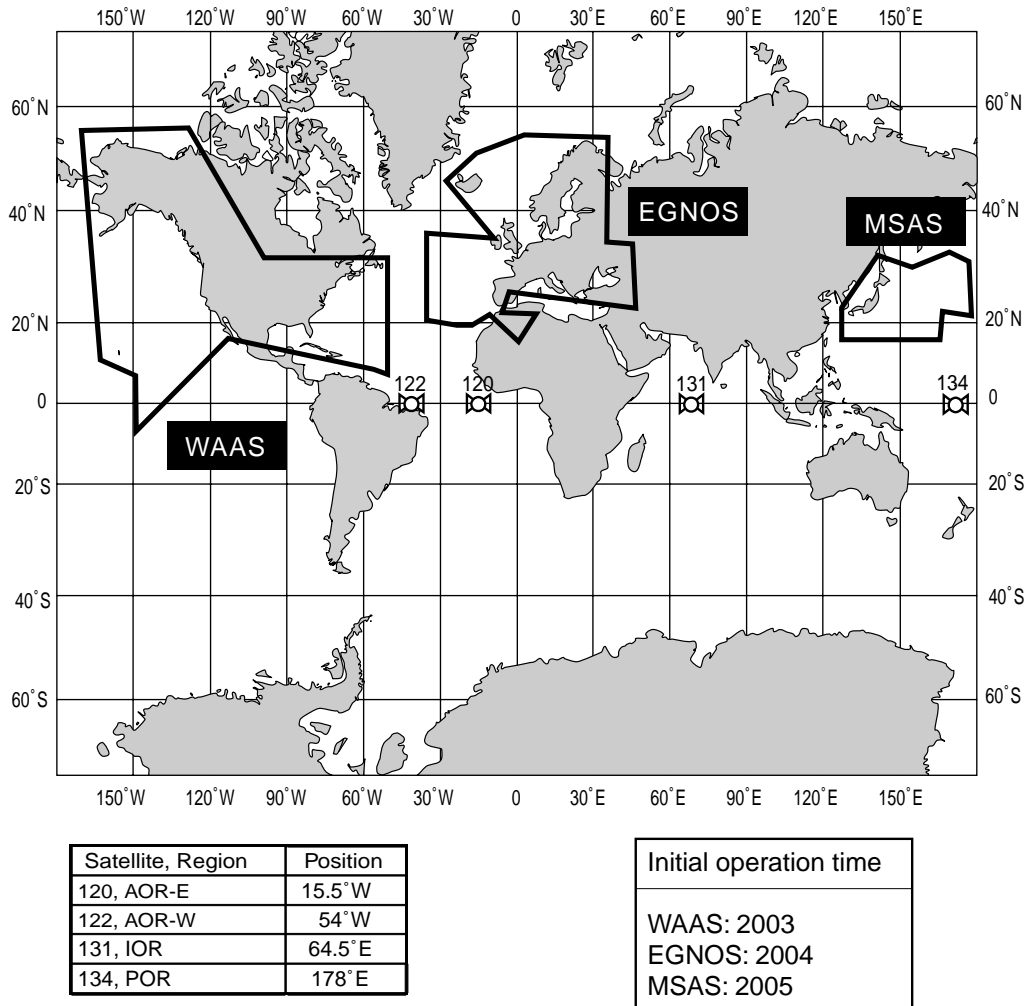

At the time of this software release, SBAS is still under development. (Providers are expected to have initial operations capability from the times shown above.) During this developmental period, which may last for several years, there is no guarantee of the accuracy, integrity, continuity, or availability of the SBAS signal. Furuno will accept no responsibility for the use of the signal for other than the above stated purpose. It is the user’s responsibility to exercise common prudence and navigational judgment while using the SBAS signal in the developmental phase.

Note: This manual uses “WAAS” when referring to any SBAS provider.

World Time Chart

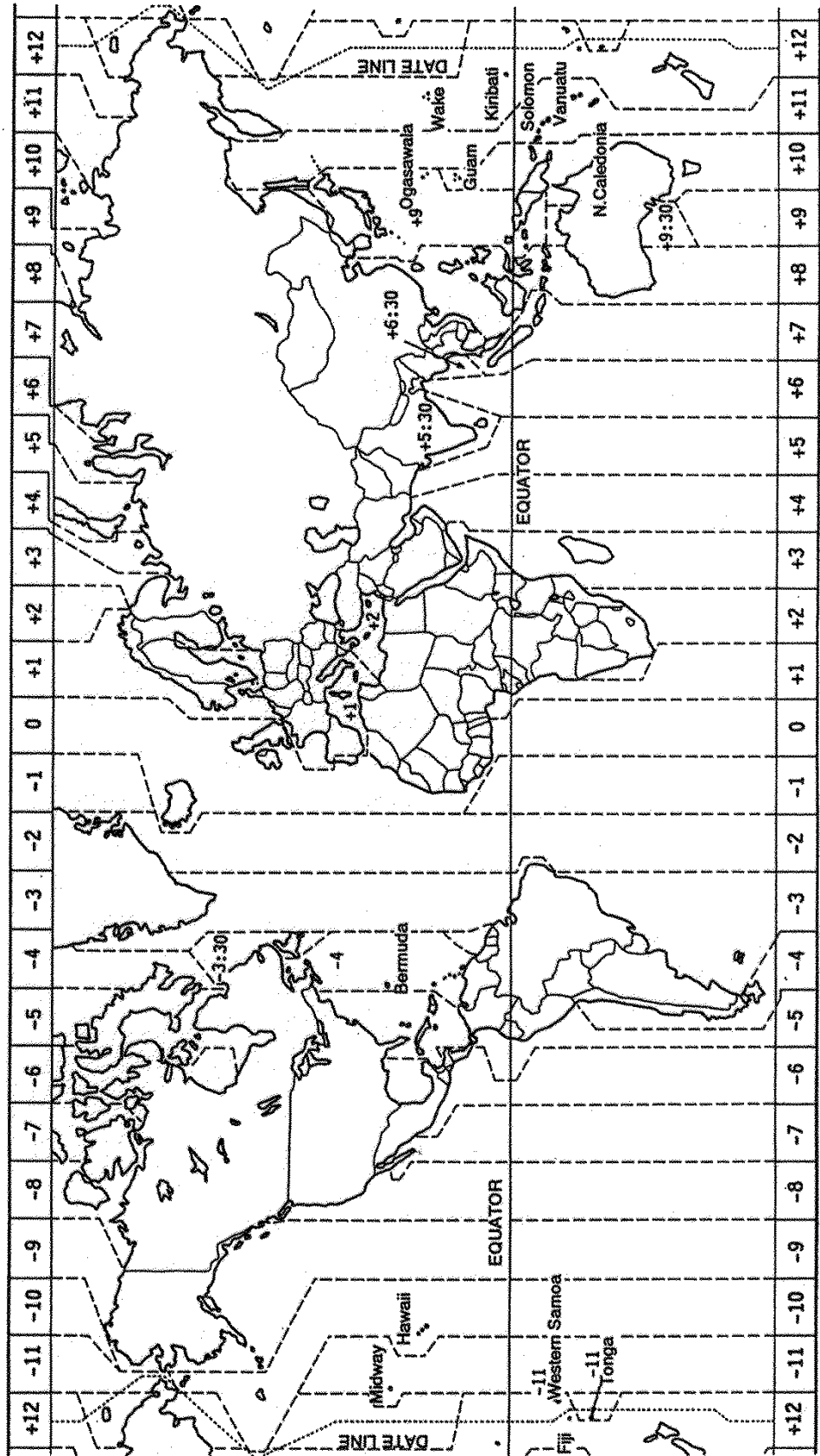

This page is intentionally left blank.

SPECIFICATIONS OF GPS PLOTTER/SOUNDER GP-7000

1 GENERAL

- | | | |
|-----|--------------|---|
| 1.1 | Display | 7-inch wide color LCD |
| 1.2 | Projection | Mercator |
| 1.3 | Usable Area | 80° latitude or below |
| 1.4 | Display Mode | Plotter, Nav Data, Highway display, Compass display |
| 1.5 | Alarms | Arrival and Anchor watch, Cross track error, Temperature, Depth, Grounding, Ship's speed alarms |

2 GPS RECEIVER

- | | | |
|-----|--------------------------|--|
| 2.1 | Receiving Channels | |
| | GPS | 12 channels parallel, 12 satellites tracking |
| | WAAS | 1 channel |
| 2.2 | Rx Frequency | 1575.42 MHz |
| 2.3 | Rx Code | C/A code, WAAS |
| 2.4 | Position Fixing System | All in view, 8-state Kalman filter |
| 2.5 | Position Accuracy | |
| | GPS | 10 m (95% of the time, HDOP ≤ 4) |
| | WAAS | 3 m (95% of the time) |
| 2.6 | Tracking Velocity | 999 kt |
| 2.7 | Position-fixing Time | Warm start: 12 s approx., Cold start: 90 s approx. |
| 2.8 | Position Update Interval | 1 s |

3 DISPLAY UNIT

- | | | |
|-----|----------------|------------------------|
| 3.1 | Display Mode | TFT color |
| 3.2 | Display Pixels | 480 (W) x 234 (H) dots |

4 PLOTTER FUNCTIONS

- | | | |
|-----|---------------------------|--|
| 4.1 | Effective Projection Area | Depending on chart card in use |
| 4.2 | Track Display | Plot interval: by time
(1 sec, 5 sec, 10 sec, 30 sec, 1 min, 5 min, 10 min, 30 min, 1 h)
or by distance (0.01, 0.05, 0.1, 0.5, 1.0, 2.0, 5.0, 10.0 nm) |
| 4.3 | Memory Capacity | Track: 12000 points, waypoint: 2000 points |
| 4.4 | Storage Capacity | Simple route: 200 routes with 35 waypoints each |
| 4.5 | MOB | 1 point |
| 4.6 | Quick Routes | 1 course |

4.7 Electronic Chart Card C-MAP NT+/MAX chart SD card

5 INTERFACE

5.1 Input data sentences IEC61162-1 and NMEA 0183 Ver1.5
DBT, DPT, MTW, TLL, WPL, VHW, HDT, HDG, DSC, MWV

5.2 Output data sentences IEC61162-1 or NMEA 0183 Ver1.5 selected on menu
\$GPAAM, \$GPAPB, \$GPBOD, \$GPBWC, \$GPBWR, \$GPGLL,
\$GPGTD, \$GPHDG, \$GPGGA, \$GPRMA, \$GPRMB, \$GPRMC,
\$GPVTG, \$GPXTE, \$GPZDA, \$GPWPL, \$GPMWV, \$GPVHW,
\$GPTLL, \$GPRTE, \$GPMTW

6 POWER SUPPLY

6.1 Display Unit 12-24 VDC: 1.5-0.8 A

7 ENVIRONMENTAL CONDITION

7.1 Ambient Temperature Antenna Unit: -20°C to +70°C
Display Unit: -15°C to +55°C

7.2 Relative Humidity 95% or less at 40°C

7.3 Water proofing Antenna Unit: IPX6
(IEC60529) Display Unit: IPX5

7.4 Vibration IEC 60945

8 COATING COLOR

8.1 Antenna Unit N9.5 (white)

8.2 Display Unit Cover: 2.5GY5/1.5, Panel: N3.0

INDEX

A

alarms	7-1, 10-18
anchor	7-5
arrival	7-2
audio	7-2
depth	7-6
grounding	7-7
STW	7-5
temperature	7-4
XTE	7-3
auto course-up	2-2
auto info	8-2

B

battery	10-2
brilliance	1-4

C

cartridge	10-6
celestial display	2-9
chart card	1-2
chart scale	2-4
compass	8-5
compass display	2-6
contrast	1-4
course-up	2-2
cursor	2-3
current setting	8-2

D

date format	8-2
diagnostics	10-5
Dim menu	10-6
display mode	8-2
download	9-3

F

fix	8-7
fuse	10-2

G

GPS cold start	10-8
----------------------	------

GPS status display	2-8
graph display	2-10

H

highway display	2-7
-----------------------	-----

K

keypad beep	8-1
-------------------	-----

L

language	8-1
----------------	-----

M

maintenance	10-1
memory card	9-1
menu	1-7
MOB	1-6

N

navigate	8-8
navigation	6-1
canceling	6-6
route	6-5
waypoints	6-4
navigation data display	2-5
North-up	2-1

P

palette	8-1
port	6-3
port service	6-3

Q

quick point	6-1
-------------------	-----

R

RAM menu	10-5
route	5-1
connecting	5-3
color	5-7
erasing	5-8
report	5-6

reversing	5-8
searching	5-8

S

serial ports	10-7
ship icon	8-2
simulation mode	1-9
soft keys.....	1-5

T

track	3-1
active	3-1
color	3-2
displaying.....	3-2
erasing	3-4
hiding	3-3
interval	3-3
method.....	3-3
time format.....	8-1
time line	8-1
time reference.....	8-1

U

units of measure	8-2
upload	9-3

W

WAAS	AP-4
waypoint.....	4-1
editing	4-4
entering.....	4-1
erasing	4-5
hiding	4-9
list.....	4-3
searching	4-7
showing.....	4-9
sorting	4-7
wind display	2-11
wind graph	8-2