

FURUNO

OPERATOR'S MANUAL

GPS RECEIVER

MODEL GP-320B



FURUNO ELECTRIC CO., LTD.
NISHINOMIYA, JAPAN



SAFETY INSTRUCTIONS



CAUTION

Confirm that the power supply voltage is compatible with the voltage rating of the equipment.

Connection to the wrong power supply can cause fire or damage the equipment.

NOTICE

No one navigation device should ever be solely relied upon for the navigation of a vessel.

Always confirm position against all available aids to navigation, for safety of vessel and crew.

TABLE OF CONTENTS

SYSTEM OVERVIEW.....	iii
EQUIPMENT LISTS	v
1. MOUNTING	1
2. WIRING	2
3. DEFAULT SETTINGS	6
4. TROUBLESHOOTING, BATTERY	7
SPECIFICATIONS.....	SP-1
PACKING LIST	
OUTLINE DRAWING	
Declaration of Conformity	

SYSTEM OVERVIEW

The GP-320B is a GPS receiver with WAAS (Wide Area Augmentation System) capability. WAAS, available in North America, is a provider in the worldwide SBAS (Satellite Based Augmentation System) navigation system. An SBAS provider furnishes GPS signal corrections to SBAS users, for even better position accuracy, typically better than three meters. Two more SBAS providers are also currently under development, MSAS (Multi-Functional Satellite Augmentation System) for Japan and EGNOS (Euro Geostationary Navigation Overlay Service) for Europe. All providers will be compatible with one another, thus providing “seamless” position fixes to SBAS users.

SBAS is currently in the developmental phase and SBAS providers are expected to have initial operations capability from the times shown below. During the developmental phase the reliability and availability of the SBAS signal cannot be guaranteed.

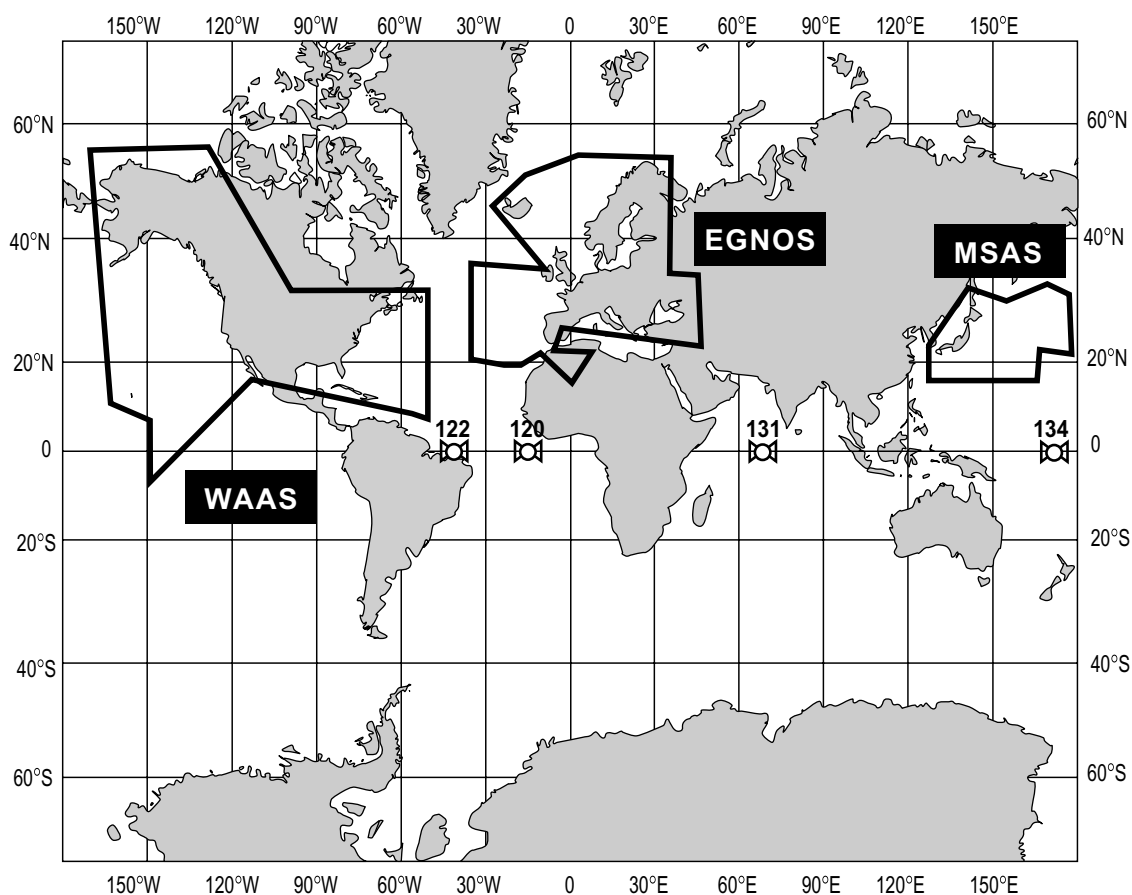

Satellite, Region	Position
120, AOR-E	15.5°W
122, AOR-W	54°W
131, IOR	64.5°E
134, POR	178°E

Expected operations capability

WAAS: 2003
 EGNOS: 2004
 MSAS: 2005

Note: Unless otherwise noted, this manual uses “WAAS” when referring to any SBAS provider.

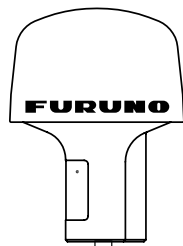

NavNet Series

Model 1722C	Model 1833C
Model 1722	Model 1933C
Model 1732C	Model 1943C
Model 1732	Model 1833
Model 1742C	Model 1933
Model 1742	Model 1943
Model 1752C	Model 1953C
Model 1752	GD-1900C
Model 1762C	GD-1700C
Model 1762	GD-1700

Multi Display RD-30*
Echo Sounder LS-6100

* = WAAS is inoperative.

Other Equipment*

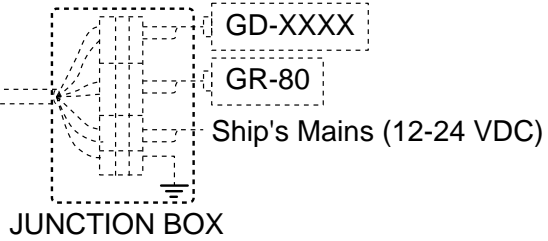

EQUIPMENT LISTS

Standard supply

Name	Type	Code No.	Qty	Remarks
GPS Receiver	GP-320B	—	1	With 10 m cable

Optional equipment

Name	Type	Code No.	Qty	Remarks
Cable Assembly	MJ-A7SPF/SRMD-100	000-144-534	1	7P-7P, straight, 10 m
Mast Mounting Kit	CP20-01111	004-365-780	1	
Right Angle Antenna Base	NO.13-QA330	000-803-239	1	
L-angle Antenna Base	NO.13-QA310	000-803-240	1	
Handrail-mount Antenna Base	NO.13-RC5160	000-806-114	1	

(This page intentionally left blank.)

1. MOUNTING

Mounting considerations

Follow the guidelines below to choose a suitable mounting location for the antenna unit.

- The antenna may be mounted three ways: screwed into a pipe (local supply), fixed to a post with the optional mast mounting kit, or screwed into an optional mounting base. For fixing by the post or pipe, it is recommended to use stays to prevent damage to the GPS receiver.
- Select a location out of the radar beam. The radar beam will obstruct or prevent reception of the GPS signal.
- The location should be well away from a VHF antenna. A GPS receiver is interfered by a harmonic wave of a VHF antenna.
- The location should be well away from an Inmarsat antenna. Inmarsat transmission will obstruct or prevent reception of the GPS signal.
- There should be no interfering object within the line-of-sight to the satellites. Objects within line-of-sight to a satellite, for example, a mast, may block reception or prolong acquisition time.
- Mount the antenna unit as high as possible to keep it free of interfering objects and water spray, which can obstruct reception of the GPS signal if the water freezes.
- Observe the following minimum separation distances from other antenna units.

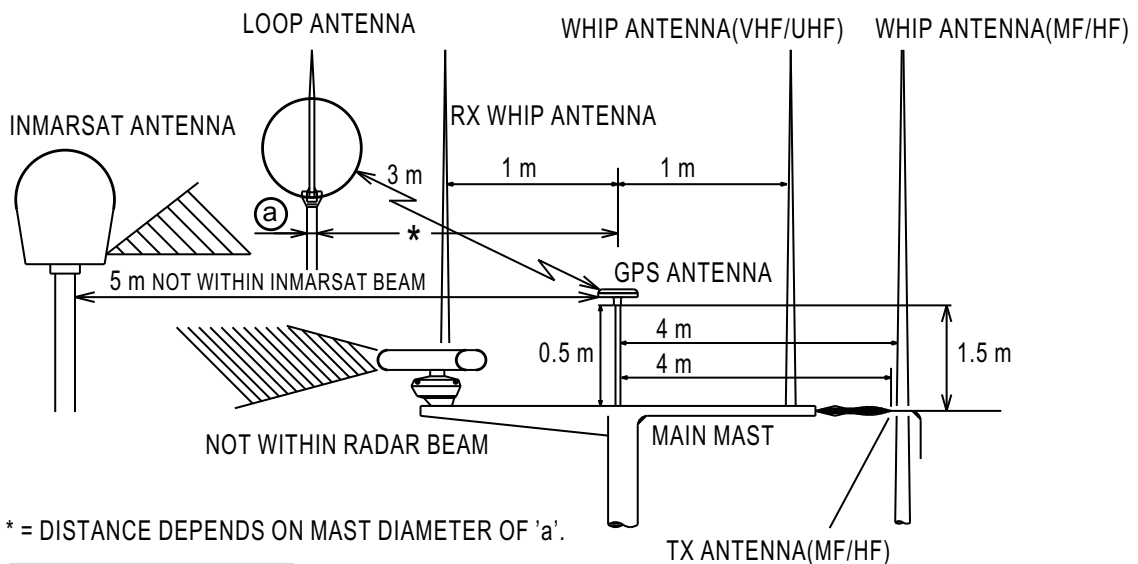

DIA. OF 'a'	DISTANCE (MIN.)
10 cm	1.5 m
30 cm	3 m

Mounting procedure

Install the antenna unit by referring to the installation diagram on page D-1.

2. WIRING

This unit outputs position and speed to external equipment. NavNet equipment, Multi Display RD-30 and Echo Sounder LS-6100 can be connected directly. For connection to other equipment, use a junction box (local supply) which has seven terminals.

The antenna cable is 10 meters long. If the distance between the antenna unit and the display monitor is more than 10 meters, use the optional cable assy. (10 m). Up to four extension cables can be connected serially.

Connecting to FURUNO NavNet equipment

Connect the antenna cable to the DATA1 port on NavNet equipment.

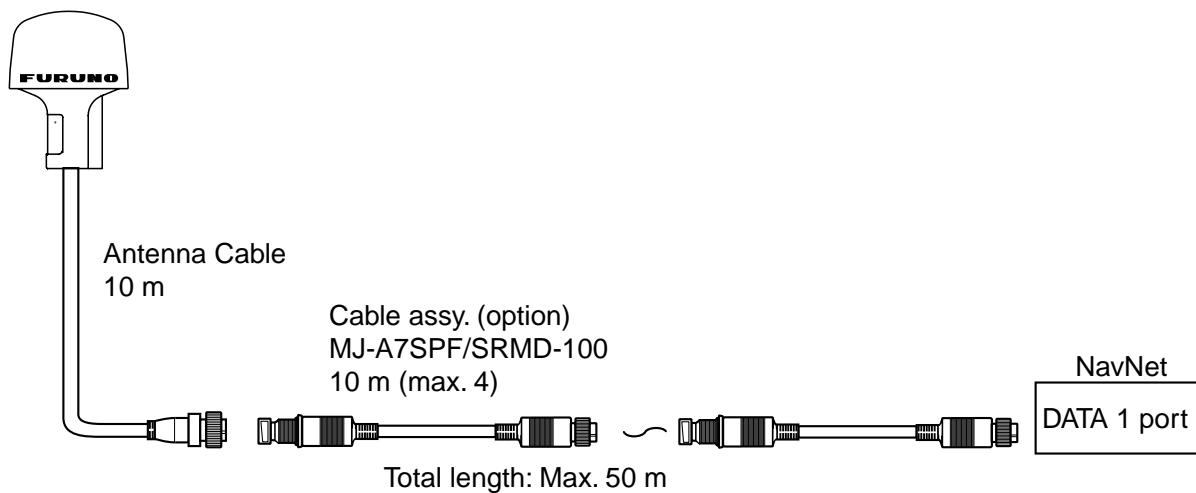

Waterproofing connectors

If you use the cable assy.(s), waterproof their connectors by wrapping them with vulcanizing tape and then vinyl tape. Bind tape ends with suitable cable-ties.

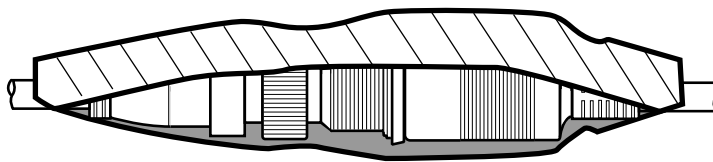

Connecting to Multi Display RD-30

WAAS is not operative in this installation.

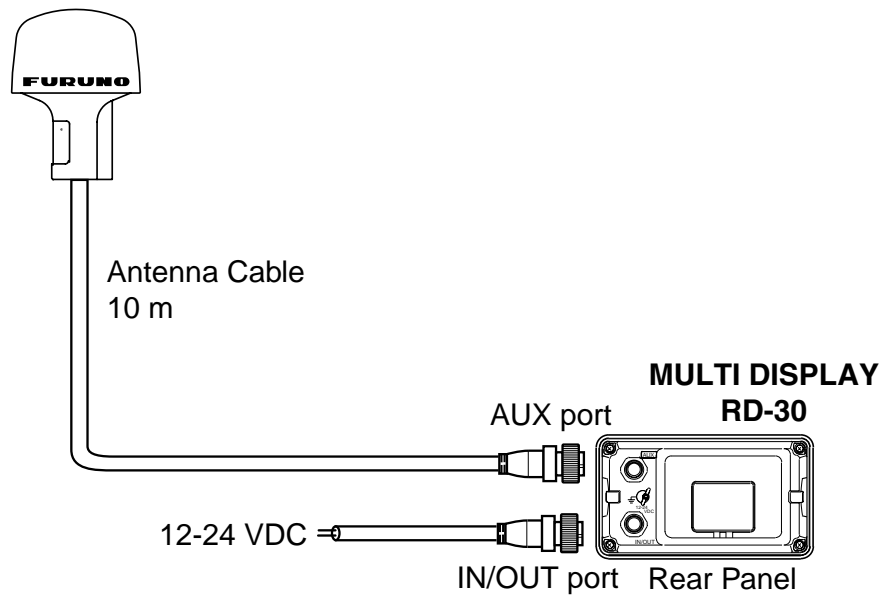

Connecting to Echo Sounder LS-6100

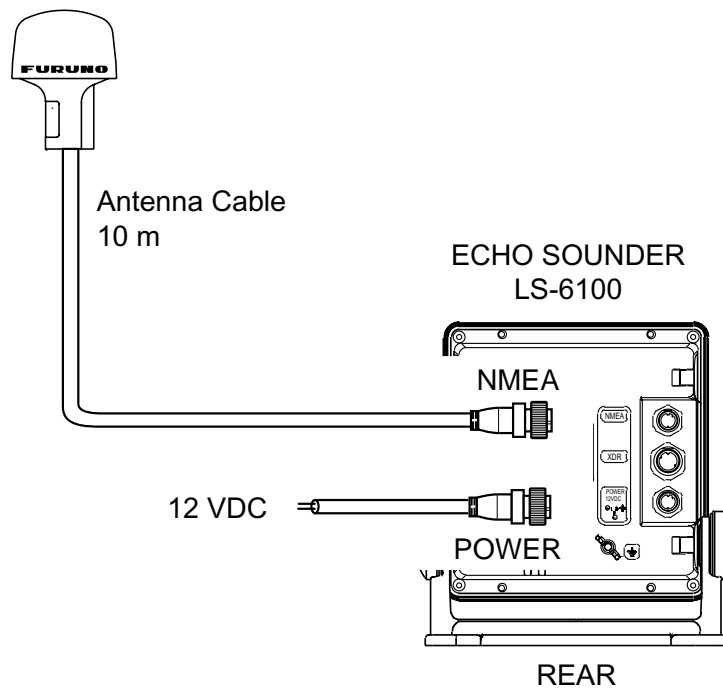

Connecting to other equipment

Remove the connector from the antenna cable and attach crimp-on lugs or similar terminals to the cable's cores. Connect the cores to the junction box as below.

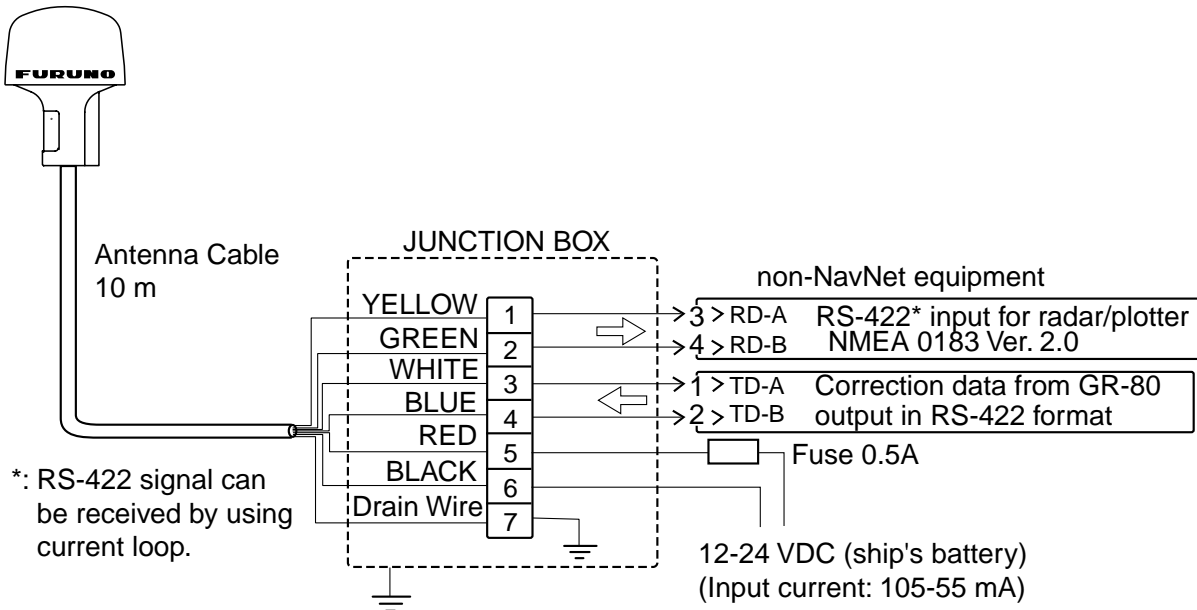

Note 1: When connecting FURUNO DGPS beacon receiver GR-80 to this unit, set it as follows:

Byte Format, 8-6; First Bit, LSB; Parity Bit, None; Stop Bit, 1; Bit Rate, 8.

Note 2: The signal ground and frame ground are separated, however the power line is not isolated. Therefore, do not connect the signal ground to the frame ground when other equipment is connected to a positive ground battery.

Note 3: WAAS function is inoperative when wiring as shown above.

Output/Input data sentences

Priority	Input Data		Output Data		Settable Output Cycle	Default Output
High ↑			GPDTM	Geometric datum	Yes	Yes
	XXGGA	GPS position status (time of fix, latitude, longitude, receive status, satellite used)	GPGGA	GPS fix data	Yes	Yes
	XXZDA	UTC date (time in minutes and seconds, day, month, year, time)	GPZDA	UTC time and date	Yes	Yes
	XXGLL	Position (latitude, longitude)	GPGLL	Geographic position, latitude and longitude	Yes	Yes
			GPVTG	Course over ground and ground speed	Yes	Yes
↓ Low	XXRMC	Navigation data (UTC time and latitude, longitude, ground speed, true course, year, month, day)	GPRMC	Recommended minimum specific GPS/TRANSIT data	Yes	Yes

Note 1: Data output from high to low priority.

Note 2: GPDTM data is attached in front of GPGGA, GPGLL and GPRMC when those sentences are output.

Note 3: "XX" means talker ID.

3. DEFAULT SETTINGS

	Setting	Default setting	Backup
GPS	Initial Latitude/Longitude	North=34°44.0000, East=135°21.0000	Yes
	Date, Time	2001/1/1, 00:00:13	Yes
	Antenna Height	0 m	Yes
	Almanac Data	—	Yes
	Ephemeris Data	—	Yes
RECEIVER	Local Zone Time	+0	Yes
	PDOP	6	Yes
	Geometric Datum	WGS84	Yes
	Mask Elevation	5°	Yes
	Disable Satellite	None	No
	Smoothing Coefficient	2 (Standard)	No
	Dynamic Coefficient	2 (Standard)	No
	Data Output (Cycle)	DTM, GGA, ZDA, GLL, VTG, RMC (1 s)	Yes
DGPS Setting Parameter	1 (LSB first)	Yes	
WAS	GEO Satellite, Provider ID	Auto: from 120, in sequential order	No
	WAAS Availability	OFF	No
	Type 0 Message	0: Correct data not output for 60 s	Yes

4. TROUBLESHOOTING, BATTERY

Troubleshooting

If the message “No position data” appears on the display of NavNet equipment, there may be a problem with the GPS receiver. Turn off the power and then check the following points:

- 1) Check for objects around the antenna which may interfere with reception.
- 2) Check that the antenna cable is firmly fastened.
- 3) If extension cable(s) are used, check for water leakage at junction point(s).
- 4) Check the antenna cable for damage.
- 5) Check the antenna for damage.

If the problem seems to be with the antenna cable or antenna, contact your dealer.

Battery

The antenna unit contains a lithium battery which preserves data when the power is turned off, and its life is approximately 20 years (operating rate 70%) for large vessels and 10 years (operating rate 20%) for small vessels. The equipment can be used when the voltage of the battery is low, however data is not backed up and the unit starts up in the “cold start” condition.

SPECIFICATIONS OF THE GPS RECEIVER GP-320B

1. GENERAL

1.1 Receiving Channels

GPS	12 channels parallel, 12 satellites tracking
WAAS	1 channel

1.2 Rx Frequency 1575.42 MHz

1.3 Rx Code C/A code, WAAS

1.4 Position Fixing System All in view, 8-state Kalman filter

1.5 Position Accuracy

GPS	10 m (95% of the time, HDOP 4)
DGPS	5 m (95% of the time, external data required)
WAAS	3 m (95% of the time)

1.6 Tracking Velocity 999 kt

1.7 Position-fixing Time Warm start: 12 s approx., Cold start: 90 s approx.

1.8 Position Update Interval 1 s

2. I/O INTERFACE

2.1 Data format IEC 61162-1 (NMEA 0183 Ver 2.30)

2.2 Output data DTM, GGA, ZDA, VTG, GLL, RMC

2.3 Input data DGPS: RTCM SC-104
Control command

3. POWER SUPPLY

12-24 VDC: 105-55 mA

4. ENVIRONMENTAL CONDITION

4.1 Ambient Temperature -25°C to +70°C

4.2 Relative Humidity 95% at 40°C

4.3 Water proofing IEC 60529: IPX6

4.4 Vibration IEC 60945

5. COATING COLOR

N9.5

PACKING LIST

20AW-X-9852 -0 1/1

GP-320B (E)

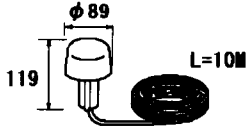
NAME	OUTLINE	DESCRIPTION/CODE No.	Q'TY
ユニット	UNIT		
GPS受信機 GPS RECEIVER		GP-320B(E) 004-367-500	1

(略図の寸法は、参考値です。 DIMENSIONS IN DRAWING FOR REFERENCE ONLY.)

C4422-Z02-A

マストへの取付け MAST MOUNTING

0) マスト取付金具CP20-0111(C)がジョイントマストに固定する。
USE MAST MOUNTING KIT CP20-0111 (OPTION).

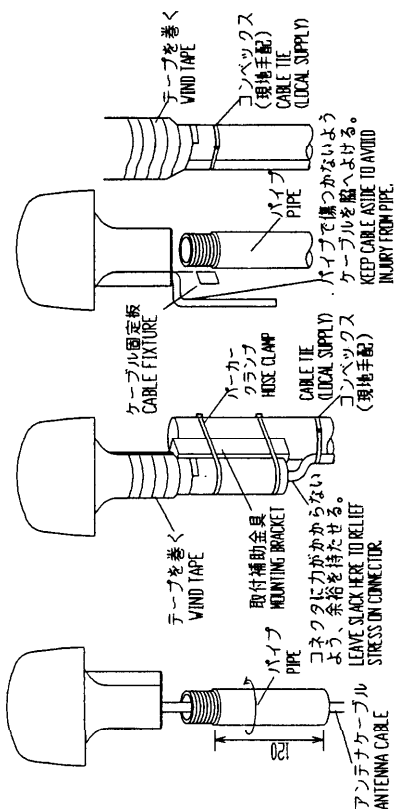

B) スタンションやバルビットにつけるときの HANDRAIL MOUNTING

レール用アンテナベース No.13-RC5160 (コード番号: 000-806-114)
取付可能レール径: φ19~φ32
USE HANDRAIL MOUNTING BASE No.13-RC5160 (CODE No.000-806-114, OPTION)
THE DIAMETER OF THE HANDRAIL MAY BE FROM φ19mm TO φ32mm.

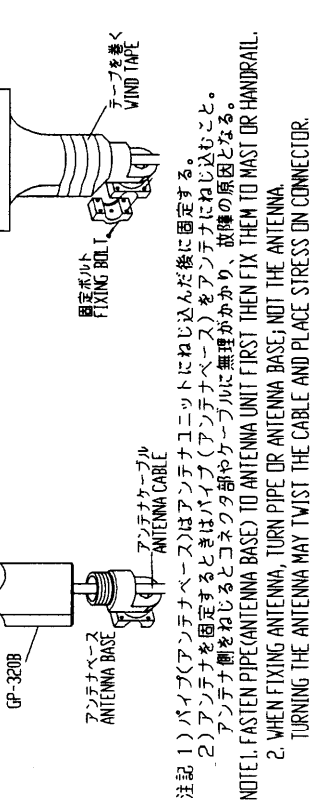

注記 1) パイプ(アンテナベース)はアンテナユニットにねじ込んだ後に固定する。
2) アンテナを固定するときにはパイプ(アンテナベース)をアンテナにねじ込むこと。
アンテナ側をねじるとコネクタ部やケーブルに無理がかかり、故障の原因となる。
NOTE 1. FASTEN PIPE(ANTENNA BASE) TO ANTENNA UNIT FIRST THEN FIX THEM TO MAST OR HANDRAIL.
2. WHEN FIXING ANTENNA, TURN PIPE OR ANTENNA BASE; NOT THE ANTENNA.
TURNING THE ANTENNA MAY TWIST THE CABLE AND PLACE STRESS ON CONNECTOR.

C) 取付ける場所が傾斜しているとき ANTENNA BASE MOUNTING

オプションのアンテナベースを使う。
USE OPTIONAL ANTENNA BASE

傾斜角 INCLINATION	5° - 33°	32° - 65°	65° - 98°
取付方法 MOUNTING METHOD			
アンテナベース型式 ANTENNA BASE TYPE	右型アンテナベース No.13-0A330 000-803-219	L型アンテナベース No.13-0A310 000-803-240	

取付場所 MOUNTING LOCATION

THE FIGURE BELOW SHOWS THE RECOMMENDED SEPARATION DISTANCES FROM OTHER ANTENNAS TO AVOID MUTUAL INTERFERENCE. 他の機器のアンテナから下の図の距離以上離す。



表 1 TABLE 1

寸法(mm) DIMENSION	公差(mm) TOLERANCE
0 < L ≤ 50	±1.5
50 < L ≤ 100	±2.5
100 < L ≤ 500	±3

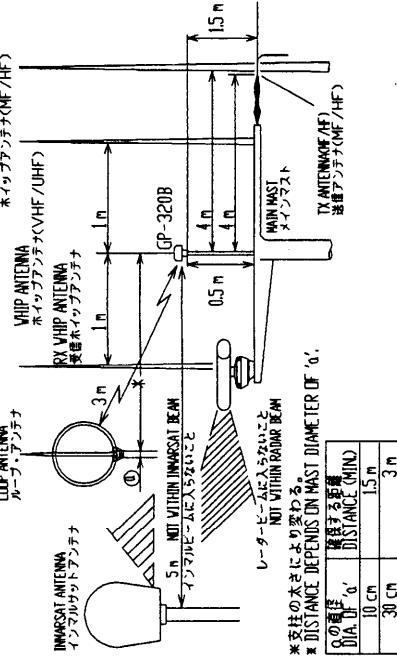
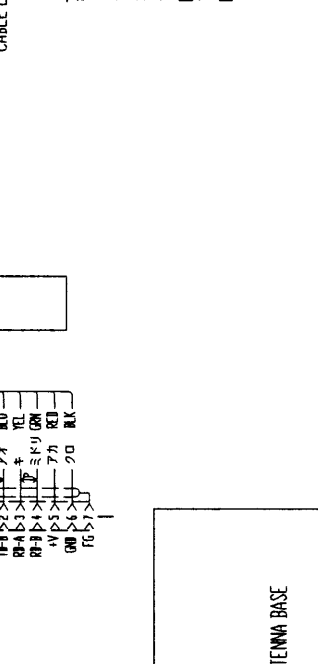
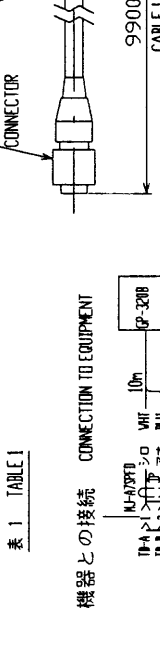

注記: 指定外の寸法公差は表 1 による
NOTE: TABLE 1 INDICATES TOLERANCE OF DIMENSIONS.

DRAWING No. 40015 02	J. YAMASAKI	TITLE	GP-320B
APPROVED	40015 01 1 Y. K.	名称	GPS受信機
SCALE	1/2	型式	外寸図
FIG. No.	C4422-G01-B	機種	GPS RECEIVER
		質量	質量はケーブルを含む。 MASS W/ CABLE
		寸法	20-023-100G-1
		図名	OUTLINE DRAWING

FURUNO**FURUNO ELECTRIC CO., LTD.**

9-52 Ashihara-Cho, Nishinomiya City, 662-8580, Hyogo, Japan

Tel: +81 798-65-2111 Fax: +81 798-65-4200

Pub NO. DOC-461

Declaration of ConformityWe **FURUNO ELECTRIC CO., LTD.**-----
(Manufacturer)

9-52 Ashihara-Cho, Nishinomiya City, 662-8580, Hyogo, Japan

(Address)

declare under our sole responsibility that the product

GPS receiver Model GP-320B-----
(Model name, serial number)

is in conformity with the essential requirements as described in the Directive 1999/5/EC of the European Parliament and of the Council of 9 March 1999 on radio equipment and telecommunications terminal equipment (R&TTE Directive) and satisfies all the technical regulations applicable to the product within this Directive

EN 60945: 1997-01 (IEC 60945 Third edition: 1996-11)

EN 60950: 2000 (IEC 60950: 1999-04)

(title and/or number and date of issue of the standard(s) or other normative document(s))

For assessment, see

- Statement of Opinion N° 02214062/AA/00 of 10 April 2002 issued by Telefication, The Netherlands
- EMC Test report FLI 12-02-004 of 25 February 2002 and Safety Test report FLI 12-02-005 of 28 February 2002 prepared by Furuno Labotech International Co., Ltd.

On behalf of Furuno Electric Co., Ltd.

Hiroaki Komatsu
Manager,
International Rules and Regulations

Nishinomiya City, Japan
June 17, 2002

(Place and date of issue)-----
(name and signature or equivalent marking of authorized person)

© **FURUNO ELECTRIC CO., LTD.**

9-52 Ashihara-cho,
Nishinomiya, Japan

Telephone : 0798-65-2111

Telefax : 0798-65-4200

Your Local Agent/Dealer

All rights reserved.

Printed in Japan

PUB.No. OME-44220

(YOSH) GP-320B

FIRST EDITION : APR. 2002

B : JUL. 03,2002



* 0 0 0 8 0 9 2 9 1 0 0 *



* O M E 4 4 2 2 0 B 0 0 *