



FURUNO®

21" High resolution Multi-color LCD radar
to 10,000 GT SOLAS ship

ARPA MARINE RADAR

WITH FULL ARPA AND AIS FUNCTION

Models **FAR-2117/2127/2137S**

- Improved detection capability by new MIC and I/F amplifier
- LCD display providing crisp echo images
- Two independent X- and S-band radars can be interswitched to meet SOLAS requirements on ships 3,000 - 10,000 GT
- Easy operation by customizable function keys, trackball/wheel palm module, and rotary controls
- Low spurious magnetrons meeting ITU-R unwanted emission standards
- ARPA functions is provided as a standard: displaying 100 ARPA targets acquisition
- Displays 1000 of AIS symbols
- X- and S-band dual installations without an extra interswitch device



The future today with FURUNO's electronics technology.

FURUNO ELECTRIC CO., LTD.

9-52 Ashihara-cho, Nishinomiya City, Japan Phone: +81 (0)798 65-2111
Fax: +81 (0)798 65-4200, 66-4622 URL: www.furuno.co.jp

Catalogue No. R-185

TRADE MARK REGISTERED
MARCA REGISTRADA

FURUNO's user friendly concept and Reliable performance,



Keyboard Type with trackball

You can perform most operations with this Multi-Function control (trackball) and the rotary wheel. The trackball is easy to use thanks to the ergonomically designed palm rest. The Palm Control Unit is selectable as a main control unit. (Specify when ordering.)



Trackball Type

Alternative of the full-keyboard Control Unit or additional as a remote operation.

Leading-edge technology are integrated! Ease of installation...

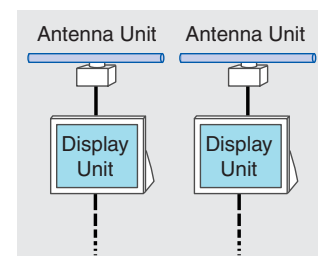
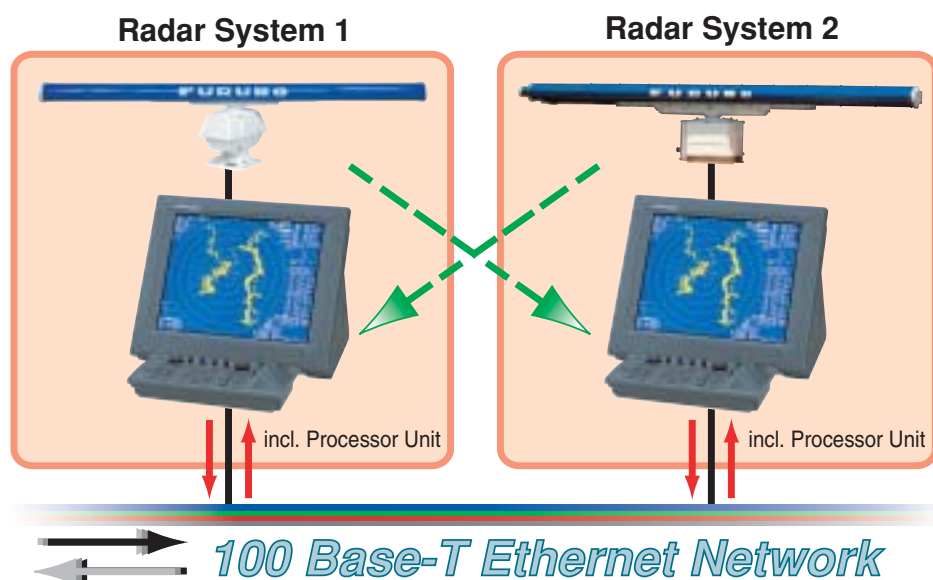

Stand-alone radar system

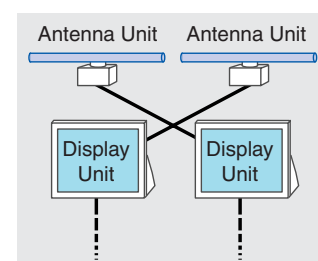

Interswitch

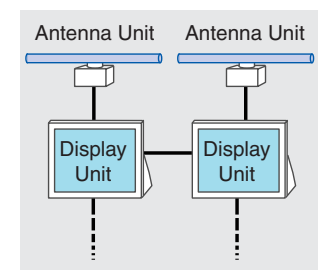

Remote operation

- **Other Radar Images**
- **Chart Information**
- **COG**
- **SOG**
- **STW etc.**

The radars can be connected in the Ethernet network for a variety of user requirements. SOLAS Chapter V as amended requires X- and S-band radars on 3,000 GT ships and larger. Each of X- and S-band radars can be interswitched without using an extra option. Up to four radar can be

interchanged in the network. In addition, the essential navigational data including the electronic chart, L/L, COG, SOG, STW, etc. can be supplied on Ethernet.

The revolutionary FAR-21x7 series of X and S-band radars are the result of FURUNO's 50 years of experience in the marine electronics and advanced computer technology. This series of equipment is designed to meet the exacting standards of the International Maritime Organization (IMO) for ships of 1000 GT and more but less than 10000 GT. (NOTE: 300 GT ships can carry this series of radars)

The display unit employs a 20.1" LCD. It provides an effective picture diameter of larger than 250 mm. The SXGA monitor provides crisp radar echoes, which are presented in a selected color with a day or night background color for easy observation all lighting conditions. Different colors are assigned for marks, symbols and texts for user-friendly operations.

Target detection is enhanced by sophisticated signal processing techniques such as multi-level quantization (MLQ), echo stretch, echo average, and radar interference rejecter. Two guard zones can be set at required ranges in any sector. Other ship's movements are assessed by advanced target tracking software and alerted by CPA/TCPA data readouts. The FAR-21x7 series provide ARPA and AIS (transponder unit is required to connect) function as a standard.

A variety of radar antenna is selectable from; 4, 6.5, 8 feet radiator. The rotation speed is selectable from 24 rpm for standard radars or 42 rpm for HSC. The S-band radar FAR-2137S is also available. The S-band radar assures target detection in adverse weather where X-band radar are heavily affected by sea or rain clutter.

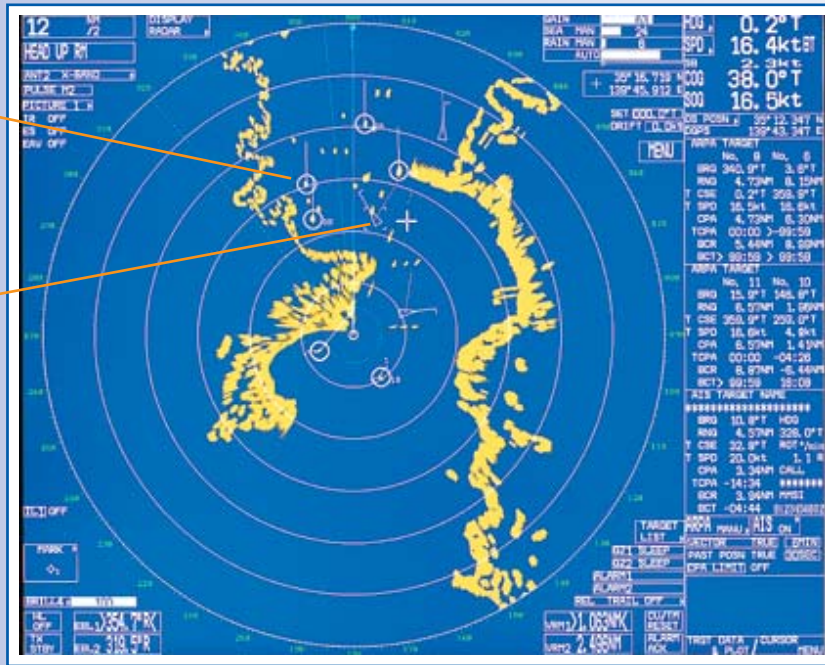

ARPA targets automatically acquired

AIS target selected for data reading.

Own ship's data

Data cells for six ARPA targets as selected by the operator. Target selected are marked with a square symbol on the radar display.

AIS

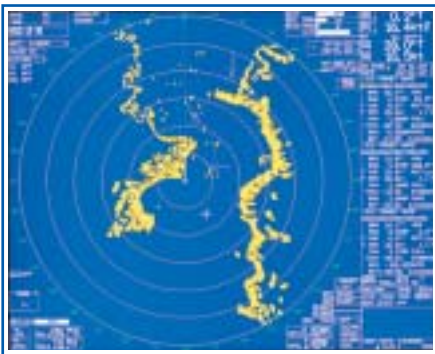

TARGET TRAILS

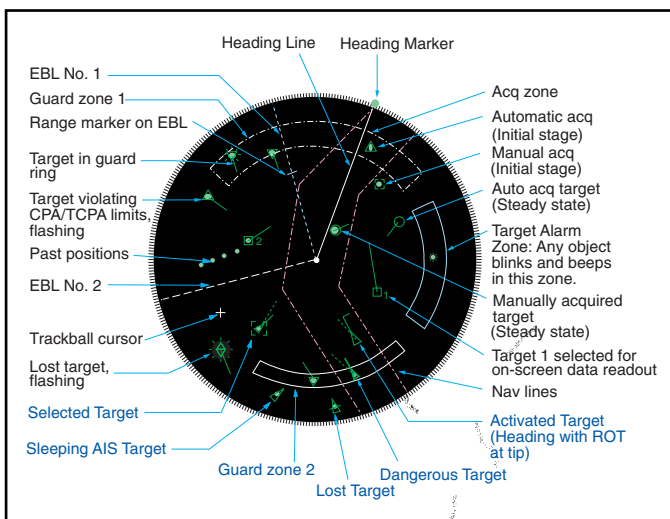
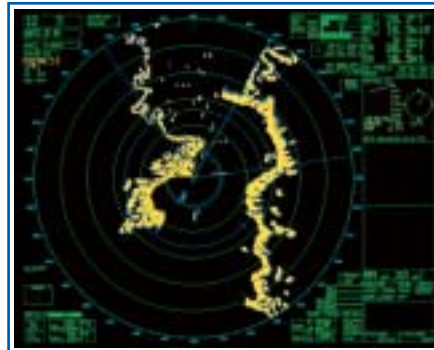

The target trails feature generates monotone or gradual shading afterglow on all objects on the display. The shading afterglow paints the display just like on an analog PPI for general use, whereas the monotone trails are useful to show own ship movement and other ship tracks in a specific fishing operation. The trail time is selectable from 15 s, 30 s, 1, 3, 6, 15, 30 min to continuous. The target trails are indicated in a different color from background colors. The unique feature in this radar/ARPA is a choice of True or Relative mode in Relative Motion (only True in TM).

Heading Line: A continuous radial line for indicating own ship's heading (called heading flasher or heading marker in older radar standards.)

Heading Marker: A mark on the bearing scale, required by the IMO MSC.64(67) Annex 4 after 1.1.1999. If off centering is performed on the above display, the Heading Line will move accordingly but the Heading Marker will remain at the same place on the bearing scale.

Past positions are shown only for target 2, but in reality all targets have their own past positions at operator selected intervals. All ARPA symbols comply with IEC 60872-1.

NIGHT VIEW

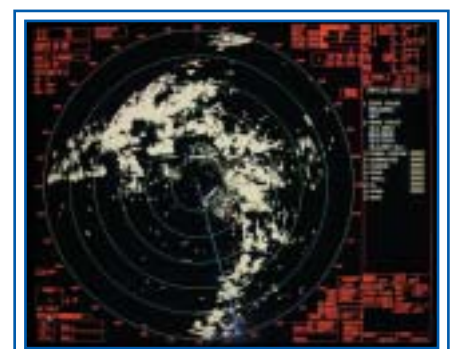

X-band antenna for FAR-2117, 2127



8 ft antenna
(4 or 6.5 ft available)

Performance Monitor
built in



S-band antenna for FAR-2137S

(It will be introduced next spring.)



Performance Monitor
built in

GUARD ZONE

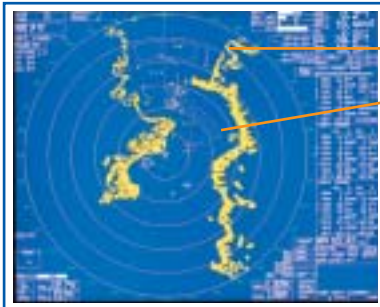

Guard
Zone



Polygon
Guard Zone

FAR-2117	X-band, 12 kW, TR up
FAR-2127	X-band, 25 kW, TR up
FAR-2137S	S-band, 30 kW, TR up

Up to Two target acquisition areas are provided. These areas also act as suppression areas, avoiding unnecessary overloading to the processor and clutter on the screen by disabling acquisition and tracking. The operator can acquire important targets without restriction outside of these areas by manual acquisition. Targets, which enter guard zones, change their tracking symbols from a circle to an inverse triangle. A target appears as a triangle when its predicted motion violates the operator set CPA and TCPA. The operator can readily change the vector lengths to evaluate the target movement trend. The polygon guard zoom is also available to watch the specified area.

RADAR MAP

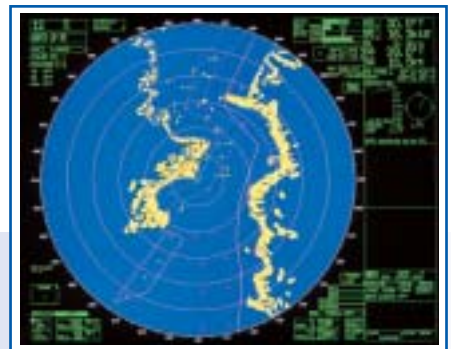
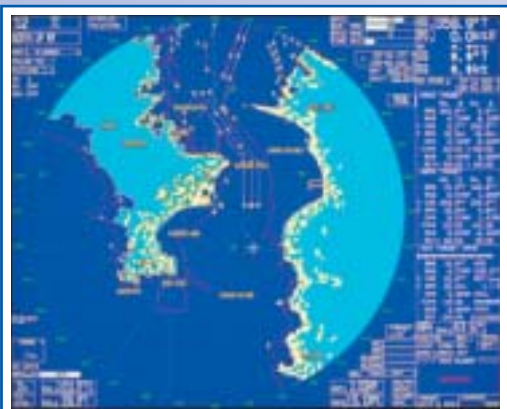

CHART OVERLAY



A map is a combination of map lines and symbols to aid route planning and monitoring on the radar equipment. 30 nav lines may be stored and each line may contain up to 30 waypoints. Five nav lines may be simultaneously shown on the display. 200 waypoints are available. Own ship and other ship tracks may be stored at a selected interval for repeated use. The two IC cards can be installed on the processor unit; Memory card (SRAM IC) stores 6,000 points of own ship and other reference locations, and the Chart card (ROM IC) carries electronic charts, from official or private source, in an ample capacity. One type of official electronic charts is ERC (Electronic Reference Charts) available from the Japanese Hydrographic Bureau.

Specifications of FAR-2117/2127/2137S

Antenna Radiators

1. Type Slotted waveguide array

2. Beamwidth and sidelobe attenuation

Radiator Type	X-Band			S-Band	
	XN-12AF	XN-20AF	XN-24AF	SN-30AF	SN-36AF
Length	4 ft	6.5 ft	8 ft	10 ft	12 ft
Beamwidth(H)	1.9°	1.23°	0.95°	2.3°	1.8°
Beamwidth(W)	20°	20°	20°	25°	25°
Sidelobe (within ± 10°)	-24 dB	-28 dB	-28 dB	-24 dB	-24 dB
Sidelobe (outside ± 10°)	-30 dB	-32 dB	-32 dB	-30 dB	-30 dB

3. Rotation X band: 24 rpm or 42 rpm
S band: 21 rpm (50 Hz), 26 rpm (60 Hz)

RF Transceiver

1. Frequency

X-band: 9410 MHz ±30 MHz

S-band: 3050 MHz ±30 MHz

2. Output power

FAR-2117: 12 kW

FAR-2127: 25 kW

FAR-2137S: 30 kW

3. Pulse length/PRR

Range scale (nm)	Pulse length (μs)	PRR (Hz)
0.125, 0.25	0.07	3000
0.5	0.07, 0.15	3000
0.75, 1.5	0.07, 0.15, 0.3	3000, 1500
3	0.15, 0.3, 0.5, 0.7	3000, 1500, 1000
6	0.3, 0.5, 0.7	1500, 1000
12, 24	0.5, 0.7	1000
48, 96	1.2	600

4. I.F. 60 MHz, Logarithmic

Bandwidth Short pulse: 40 MHz
Middle pulse: 10 MHz
Long pulse: 3 MHz

5. Noise Figure 6 dB

RADAR DISPLAY

1. Picture tube

21" color LCD (SXGA 1280 x 1024 pixels),
400 (H) x 320 (V) mm,

Effective display diameter 250 mm class

Echo Color: Yellow, green or white in 32 levels

2. Minimum range: 20 m on 0.25 nm range scale

3. Range scales and ring intervals (nm)

Range: .125, .25, .5, .75, 1.5, 3, 6, 12, 24, 48, 96

Ring: .025, .05, .1, .25, .25, .5, 1, 2, 4, 8, 16

4. Range accuracy

1% of range in use or 10 m whichever is the greater

5. Range discrimination

20 m on 0.25 nm range scale

6. Presentation modes

Head-Up, Head-Up TB, Course-Up, North-Up,
North-Up TM

7. Parallel index lines

1, 2, 3 or 6 lines (menu selectable)

8. Radar map

1500 points to create coastlines, own ship safety contour, isolated underwater dangers, buoys, traffic routing systems, prohibited areas, fairways as required by IMO.

ARPA FUNCTIONS

1. Acquisition

100 targets automatically or manually

2. Tracking

Automatic tracking of all acquired targets on the display in 0.1 to 32 nm

3. Suppression areas

Combined with two acquisition areas of 3-3.5 and 5.5-6 nm, or 0.5 nm deep sector or circle in 0.3-32 nm.

4. Vector

True or relative 30 s, 1, 3, 6, 15, 30 min for prediction of target motion

5. Past positions

5 or 10 past positions of tracked targets at intervals of 30 s, 1, 2, 3, 6 min.

6. Collision warning

CPA limit: 0.2 - 10 nm, TCPA limit: 0 - 99 min.

7. Guard zone

Two zones: sector or polygon may be set in any effective area

8. Trial maneuver

Dynamic or static, with selected delay time.

AIS FUNCTIONS (Data input from AIS transponder is required)

1. Symbols

Sleeping, Activated, Dangerous, Selected, Lost targets

2. Number of targets

1,000 targets max.

3. Data indication

Basic and expanded data

4. Alarm

CPA or TCPA alarm

POWER SUPPLY (specify when ordering)

1. Processor Unit

24 VDC, 100/115/220/230/440 VAC, 1ø, 50/60 Hz

2. Antenna Unit

FAR-2137S: 110 VAC, 3ø, 60 Hz; 180 VAC, 3ø, 50 Hz
220 VAC, 3ø, 50/60 Hz; 380 VAC, 3ø, 50 Hz
440 VAC, 3ø, 50/60 Hz



EQUIPMENT LIST

Standard

1. Display Unit MU-201C
2. Processor Unit RPU-013
3. Control Unit RCU-014 (trackball with type)
RCU-015 (trackball type) Specify when ordering
4. Antenna Unit with cable (15/20/30/50/100 m)
5. RF Transceiver Unit for RF-up system
6. Power Supply unit PSU-007 for FAR-2137s
7. Standard Spare Parts and Installation Materials

Optional

1. Remote Control Unit RCU-016
2. Performance Monitor PM-31 for FAR-2117/2127,
PM-51 for FAR-2137S
3. Gyro Interface GC-10 (built in Processor Unit)
4. RGB Buffer Board (built in Processor Unit)
5. RGB Connector DSUB-BNC-1 (for VDR)
6. Card Interface Unit CU-100
7. Transformer RU-1803/3305/5466-1/5693/6522
8. Rectifier RU-3424/1746B
9. Junction Box for Antenna Cable
10. External Alert Buzzer
11. MINI Chart Card
12. Hand Grip

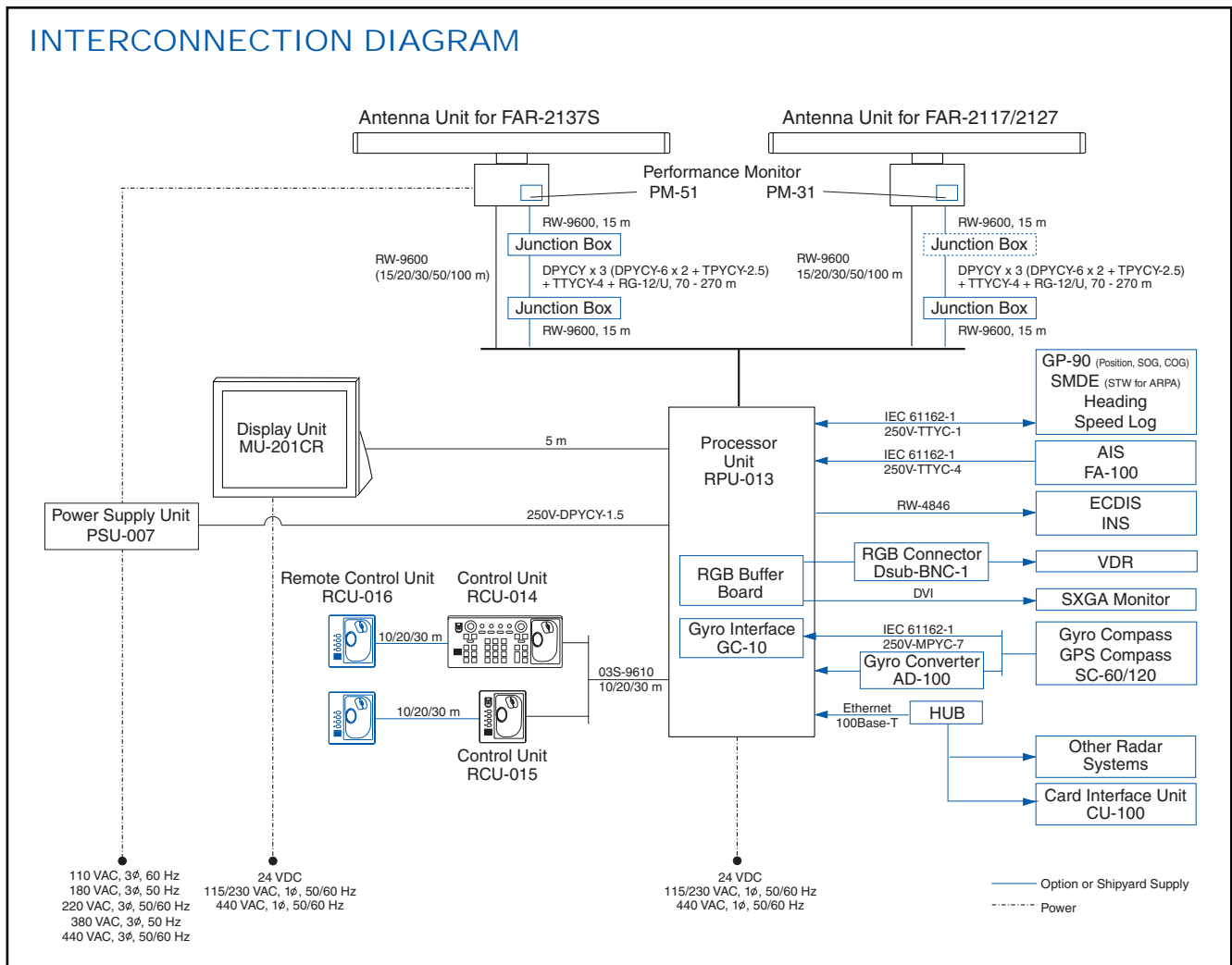

Antenna Unit for FAR-2117/2127 RSB-096/097

XN12F: 33 kg 73 lb

XN20F: 39 kg 86 lb
XN24AF: 42 kg 93 lb

XN20AF: 2040 80.3"
XN24AF: 2550 100.4"

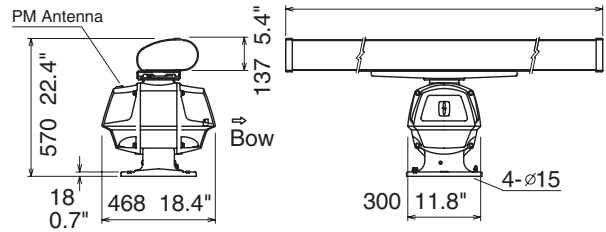
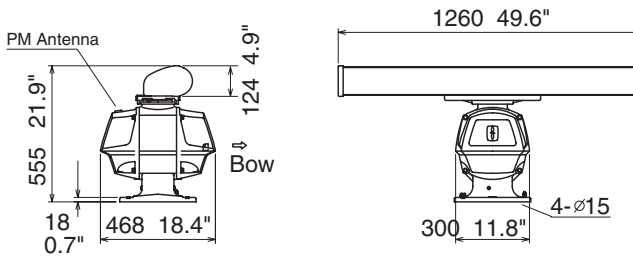

Antenna Unit for FAR-2737S RSB-098/099/100/101/102

SN-30AF: 127 kg 280 lb
SN-36AF: 133 kg 293.2 lb

SN36AF: 3765 148.2"
SN30AF: 3090 121.7"

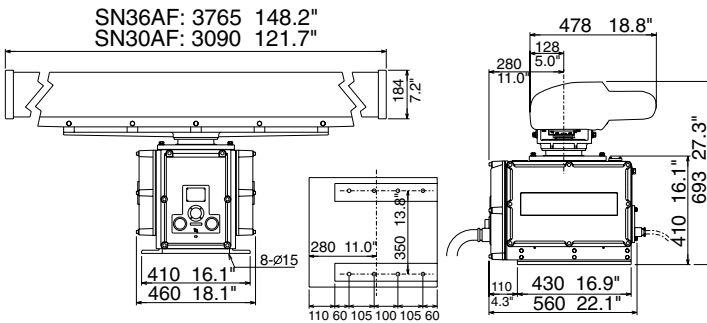

Processor Unit RPU-013

10 kg 22 lb

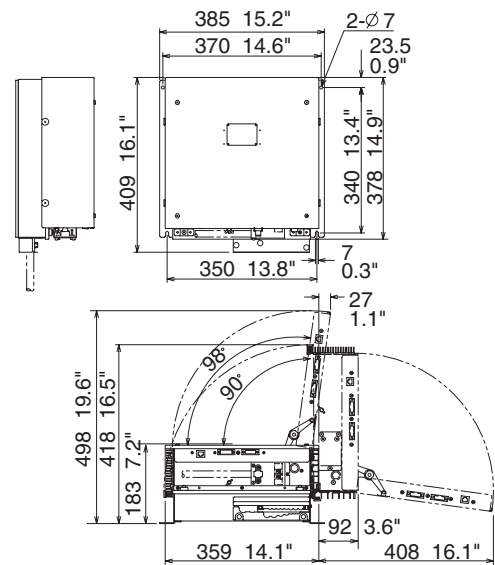

Display Unit MU-201CR 17.8 kg 39.2 lb

Bracket mount

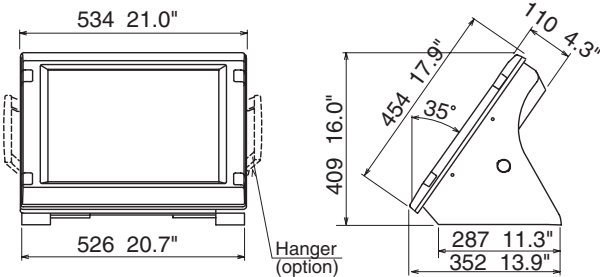

Panel mount

11.7 kg 25.8 lb

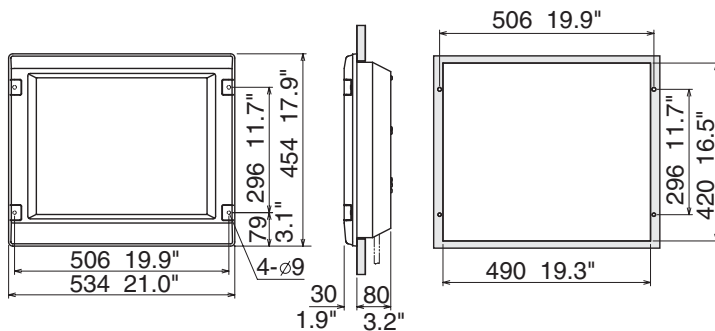

Control Unit RCU-014

2.7 kg 6 lb

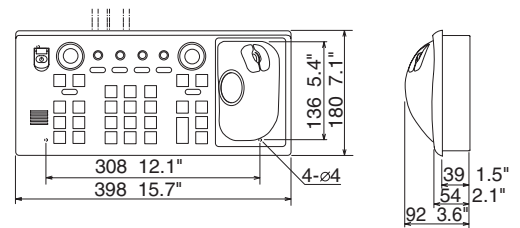

RCU-015/RCU-016

1.4 kg 3.1 lb

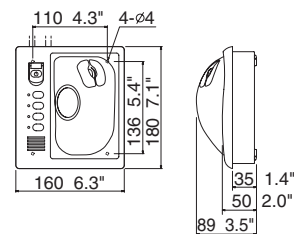

SPECIFICATIONS SUBJECT TO CHANGE WITHOUT NOTICE

0309KS Printed in Japan

FURUNO U.S.A., INC.

Camas, Washington, U.S.A.
Phone: +1 360-834-9300 Telefax: +1 360-834-9400

FURUNO (UK) LIMITED

Denmead, Hampshire, U.K.
Phone: +44 2392-230303 Telefax: +44 2392-230101

FURUNO FRANCE S.A.

Bordeaux-Mérignac, France
Phone: +33 5 56 13 48 00 Telefax: +33 5 56 13 48 01

FURUNO ESPANA S.A.

Madrid, Spain
Phone: +34 91-725-90-88 Telefax: +34 91-725-98-97

FURUNO DANMARK AS

Hvidovre, Denmark
Phone: +45 36 77 45 00 Telefax: +45 36 77 45 01

FURUNO NORGE A/S

Ålesund, Norway
Phone: +47 70 102950 Telefax: +47 70 127021

FURUNO SVERIGE AB

Västra Frölunda, Sweden
Phone: +46 31-7098940 Telefax: +46 31-497093

FURUNO FINLAND OY

Espoo, Finland
Phone: +358 9 4355 670 Telefax: +358 9 4355 6710