

FURUNO

OPERATOR'S MANUAL

NETWORK SOUNDER

MODEL **DFF3**



IMPORTANT NOTICES



- The descriptions in this manual are intended for readers with a solid knowledge of English.
- No part of this manual may be copied or reproduced without written permission.
- If this manual is lost or worn, contact your dealer about replacement.
- The contents of this manual and equipment specifications are subject to change without notice.
- Store this manual in a convenient place for future reference.
- FURUNO will assume no responsibility for the damage caused by improper use or modification of the equipment (including software) by an unauthorized agent or a third party.
- When it is time to discard this product it must be done according to local regulations for disposal of industrial waste. For disposal in the USA, refer to the Electronics Industries Alliance (<http://www.eiae.org/>).









SAFETY INSTRUCTIONS





The user and installer must read the appropriate safety instructions before attempting to install or operate the equipment.

 WARNING	Indicates a potentially hazardous situation which, if not avoided, could result in death or serious injury.
 CAUTION	Indicates a potentially hazardous situation which, if not avoided, may result in minor or moderate injury.





 Warning, Caution	 Prohibitive Action	 Mandatory Action
--	--	--

Safety instructions for the operator

 WARNING	
	Do not open the equipment. Only qualified personnel should work inside the equipment.
	Do not disassemble or modify the equipment. Fire, electrical shock or serious injury can result.
	Turn off the power immediately if the equipment is emitting smoke or fire. Fire or electrical shock can result if the power is left on.
	Turn off the power immediately if water leaks into the equipment or an object is dropped inside the equipment. Continued use can cause fire or electrical shock.
	Turn off the power immediately if you feel the equipment is acting abnormally. If the equipment is hot to the touch or is emitting strange noises, turn off the power immediately and contact your dealer for advice.





 WARNING	
	Do not operate the equipment with wet hands. Electrical shock can result.
	Do not place liquid-filled containers on the top of the equipment. Electrical shock can result.
	Do not install the equipment where it may be subjected to rain or water splash. Fire or electrical shock can result if water gets inside the equipment.
	Use the proper fuse. Use of a wrong fuse can damage the equipment and may cause fire.

A warning label is attached to the equipment. Do not remove this label. If the label is missing or illegible, contact a FURUNO agent or dealer about replacement.

 WARNING 
To avoid electrical shock, do not remove cover. No user-serviceable parts
 

Name: Warning Label (1)
Type: 86-003-1011-3
Code No.: 100-236-233-10

Safety instructions for the installer

 WARNING	
	<p>Do not open the equipment.</p> <p>Only qualified personnel should work inside the equipment.</p>
	<p>Turn off the power before beginning the installation.</p> <p>Fire or electrical shock can result if the power is left on.</p>
	<p>Be sure no water leaks at the transducer and temperature sensor.</p> <p>Water leakage can sink the vessel. Also, confirm that neither the transducer or sensor will loosen by vibration. The installer is solely responsible for the installation.</p>
	<p>Confirm that the power supply voltage is within the rating of this equipment.</p> <p>Incorrect voltage will damage the equipment and may cause fire.</p>





 CAUTION					
	<p>The transducer cable must be handled carefully, following the guidelines below.</p> <ul style="list-style-type: none"> • Keep fuels and oils away from the cable. • Locate the cable away from chemicals. • Locate the cable away from locations where it might be damaged. 				
	<p>Do not apply the power with the transducer exposed to air.</p> <p>Damage to the transducer may result.</p>				
	<p>Observe the following compass safe distances to prevent interference to a magnetic compass:</p> <table border="1" style="margin-left: auto; margin-right: auto;"> <tbody> <tr> <td style="padding: 5px;">Standard compass</td> <td style="padding: 5px;">Steering compass</td> </tr> <tr> <td style="text-align: center; padding: 5px;">0.95 m</td> <td style="text-align: center; padding: 5px;">0.60 m</td> </tr> </tbody> </table>	Standard compass	Steering compass	0.95 m	0.60 m
Standard compass	Steering compass				
0.95 m	0.60 m				

TABLE OF CONTENTS

FOREWORD	v
SYSTEM CONFIGURATION	vi
1. MOUNTING	1
1.1 Equipment Lists.....	1
1.2 Network Sounder	8
1.3 Transducer	9
1.4 Optional Speed/Temperature Sensors ST-02MSB, ST-02PSB	9
1.4.1 Mounting considerations.....	9
1.4.2 Mounting procedure.....	9
1.5 Optional Temperature Sensors	10
1.5.1 Transom mount temperature sensor T-02MTB	10
1.5.2 Thru-hull temperature sensor T-02MSB, T-03MSB	11
2. WIRING	12
2.1 Wiring Outline.....	12
2.2 Transducer Cable.....	13
3. INITIAL SETTINGS	15
3.1 Tap Setting.....	15
3.2 DIP Switch Setting	16
3.3 Operation Check	18
4. MAINTENANCE	19
4.1 Maintenance.....	19
4.2 Replacing the Fuse	20
4.3 Restoring Default Settings	20

FOREWORD

A Word to the Owner of the DFF3

Congratulations on your choice of the FURUNO DFF3 Network Sounder. We are confident you will see why the FURUNO name has become synonymous with quality and reliability.

For 60 years FURUNO Electric Company has enjoyed an enviable reputation for quality marine electronics equipment. This dedication to excellence is furthered by our extensive global network of agents and dealers.

This equipment is designed and constructed to meet the rigorous demands of the marine environment. However, no machine can perform its intended function unless operated and maintained properly. Please carefully read and follow the recommended procedures for operation and maintenance.

Thank you for considering and purchasing FURUNO.

Features

The DFF3 network sounder is a dual frequency echo sounder designed for use with the FURUNO NavNet/NavNet vx2/NavNet 3D series. The DFF3 feeds data about underwater conditions via a LAN.

A few of the features are

- FURUNO Free Synthesizer (FFS) transceiver design allows use of user-selectable operating frequencies (28 - 200 kHz).
- Automatic operation selects correct range and gain to show fish echoes and bottom in both shallow and deep waters.
- Improved discrimination of near-surface fish by eliminating the transmission line.
- Heaving compensation* stabilizes the picture against ship's pitching and rolling.
* Requires NavNet 3D display device and Satellite Compass SC-30, heading data fed in NMEA 2000[®] format.
- ACCU-FISH[®] feature estimates length and depth of individual fish.
(Transducer 50/200-1T only for use with NavNet 3D.)
- 1/2/3 kW output

Note: The terms "NavNet" and "Navnet 3D" refer to the models listed below.

Navnet/NavNet vx2	NavNet 3D
Model 17x2 Series, Model 17x2C Series, Model 17x4 Series, Model 17x4C Series, GD-1720, GD-1720C, Model 18x3C(-BB) Series, Model 18x4C(-BB) Series, Model 19x3C(-BB) Series, Model 19x4C(-BB) Series, GD-1900C(-BB), GD-1920C(-BB)	MFDBB, MFD8, MFD12

SYSTEM CONFIGURATION

Basic configuration shown with solid line.

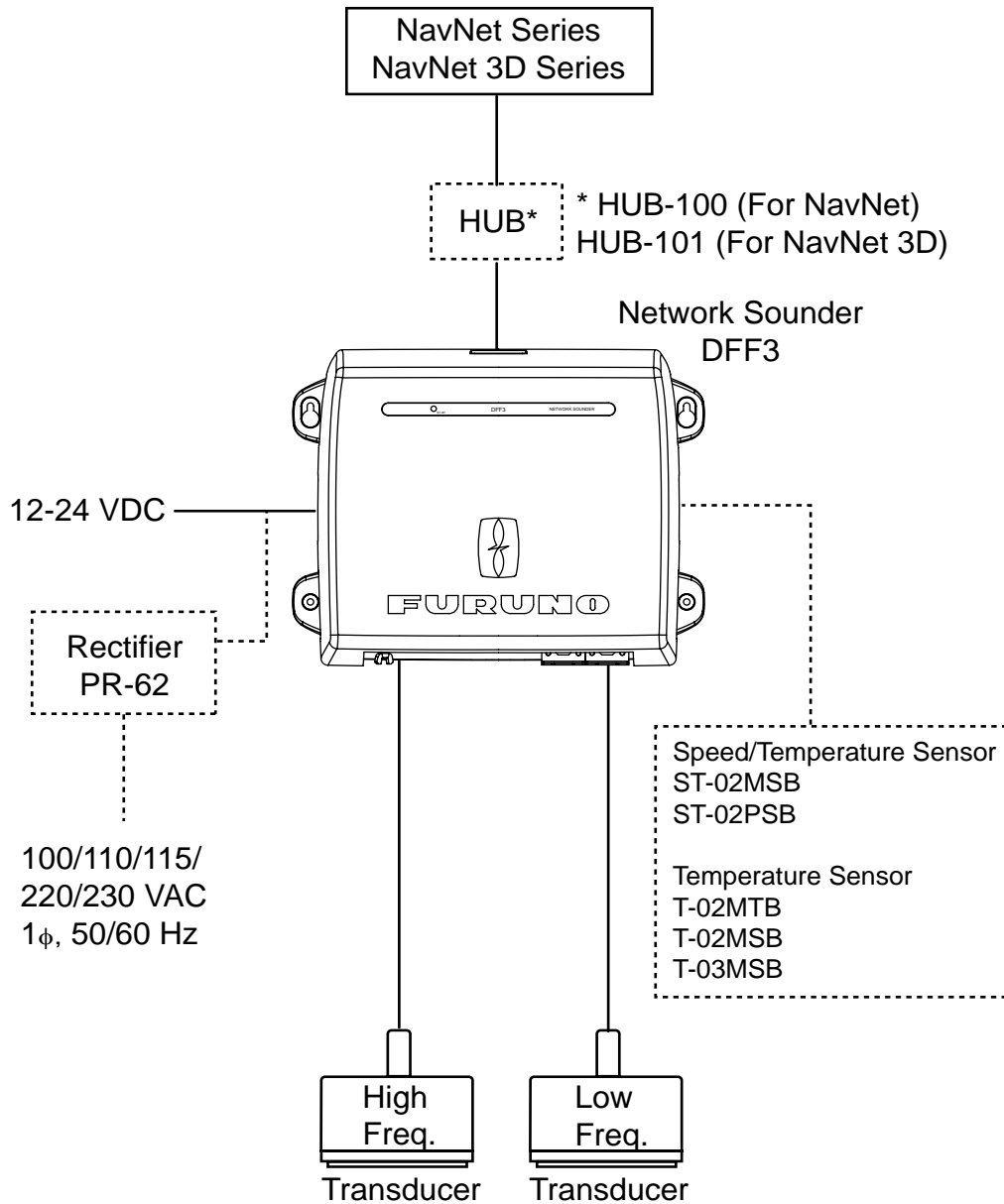

1. MOUNTING

1.1 Equipment Lists

Standard supply

Name	Type	Code No.	Qty	Remarks
Network Sounder	DFF3	—	1	
Spare Parts	SP02-05601	001-033-740	1 set	Fuse
Installation Materials	CP02-08500	000-011-917	1 set	- Power cable (3.5 m) - LAN cable (5 m for NavNet 3D) - Self-tapping screws

Optional supply

Name	Type	Code No.	Remarks
Transducer	1/2/3kW available. See next page for choices.	—	
Thru-hull pipe		—	
Tank		—	
Cable Assembly	MJ-A6SPF0017-010C	001-159-704-10	1 m, for NavNet
	MJ-A6SPF0017-050C	001-159-705-10	5 m, for NavNet
	MJ-A6SPF0017-100C	001-159-706-10	10 m, for NavNet
	MJ-A6SPF0017-200C	001-159-707-11	20 m, for NavNet
	MJ-A6SPF0017-300C	001-159-708-11	30 m, for NavNet
	MOD-Z072-020+	000-167-175-10	2 m, for NavNet 3D (HUB-101)
	MOD-Z072-100+	001-167-177-10	10 m, for NavNet 3D (HUB-101)
Speed/Temperature Sensor	ST-02MSB	000-137-986	Thru-hull mount, steel hull
	ST-02PSB	000-137-987	Thru-hull mount, plastic hull
Temperature Sensor	T-02MTB	000-040-026	Transom mount
	T-02MSB	000-040-040	Thru-hull mount
	T-03MSB	000-040-027	Thru-hull mount
Rectifier	PR-62	000-013-484	100 VAC
		000-013-485	110 VAC
		000-013-486	220 VAC
		000-013-487	230 VAC

1. MOUNTING

Transducer, thru-hull pipe and tank combinations

Output (W)	Frequency (kHz)	Ship type	Transducer	Thru-hull pipe	Tank	
1k/1k	28/50	Steel	28F-8	TWB-6000(2)	T-656	
		FRP	50B-9B	-	-	
	28/88	Steel	28F-8	TWB-6000(2)	T-657	
		FRP	88B-8	-	-	
	50/88	Steel	50B-9B	TWB-6000(2)	T-658	
		FRP	88B-8	-	-	
	50/200	Steel	50/200-1T or	TFB-5000(1)	T-603	
			50/200-1ST	-	T-603F	
		FRP	50/200-12M	-	-	
			-	-	-	
	1k/2k	28/200	Steel	28F-8	TWB-6000(2)	T-657
			FRP	200B-8/8B	-	-
50/200		Steel	50B-9B	TWB-6000(2)	T-658	
		FRP	200B-8/8B	-	-	
88/200		Steel	88B-8	TWB-6000(2)	T-659	
		FRP	200B-8/8B	-	-	

Output (W)	Frequency (kHz)	Ship type	Transducer	Thru-hull pipe	Tank
2k/2k	28/50	Steel	28F-18 50B-12	TFB-7000(2)	T-634
		FRP		TRB-1100(2)	T-634-F
	28/82	Steel	28F-18 82B-35R	TFB-7000(2)	T-636
		FRP		TRB-1100(2)	T-636-F
	28/88	Steel	28F-18 88B-10	TFB-7000(2)	T-636
		FRP		TRB-1100(2)	T-636-F
	28/200	Steel	28F-18 200B-8/8B	TFB-7000(2)	T-638
				TRB-1100(2)	T-638-F
		FRP	28BL-6HR 200B-8/8B	TFB-7000(2)	T-693
			TRB-1100(2)	T-693-F	
	38/200	Steel	38BL-9HR 200B-8/8B	TFB-7000(2)	T-693
		FRP		TRB-1100(2)	T-693-F
	50/82	Steel	50B-12 82B-35R	TFB-7000(2)	T-643
		FRP		TRB-1100(2)	T-643-F
	50/88	Steel	50B-12 88B-10	TFB-7000(2)	T-643
		FRP		TRB-1100(2)	T-643-F
	50/200	Steel	50B-12 200B-8/8B	TFB-7000(2)	T-645
				TRB-1100(2)	T-645-F
		FRP	50BL-12HR 200B-8/8B	TFB-7000(2)	T-693
			TRB-1100(2)	T-693-F	
		Steel	50BL-12 200B-8/8B	TFB-7000(2)	T-693
				TRB-1100(2)	T-693-F
	82/200	Steel	82B-35R 200B-8/8B	TFB-7000(2)	T-649
		FRP		TRB-1100(2)	T-649-F
	88/200	Steel	88B-10 200B-8/8B	TFB-7000(2)	T-649
		FRP		TRB-1100(2)	T-649-F
	28/107	Steel	28F-18 100B-10R	TFB-7000(2)	T-636
		FRP		TRB-1100(2)	T-636-F

1. MOUNTING

Output (W)	Frequency (kHz)	Ship type	Transducer	Thru-hull pipe	Tank
2k/3k	28/150	Steel	28F-18 150B-12H	TFB-7000(2)	T-637
		FRP		TRB-1100(2)	T-637-F
	50/107	Steel	50B-12 100B-10R	TFB-7000(2)	T-643
		FRP		TRB-1100(2)	T-643-F
	50/150	Steel	50B-12 150B-12H	TFB-7000(2)	T-644
		FRP		TRB-1100(2)	T-644-F
3k/2k	68/200	Steel	68F-30H 200B-8/8B	TFB-7000(2)	T-647
		FRP		TRB-1100(2)	T-647-F
	107/200	Steel	100B-10R 200B-8/8B	TFB-7000(2)	T-649
		FRP		TRB-1100(2)	T-649-F
3k/3k	28/38	Steel	28BL-12HR 38BL-15HR	TFB-7000(2)	T-681
		FRP		TRB-1100(2)	T-681-F
		Steel	28F/24H 38BL-15HR	TFB-7000(2)	T-681
		FRP		TRB-1100(2)	T-681-F
	28/50	Steel	28BL-12HR 50BL-24HR	TFB-7000(2)	T-681
		FRP		TRB-1100(2)	T-681-F
		Steel	28BL-12HR 50F-24H	TFB-7000(2)	T-681
		FRP		TRB-1100(2)	T-681-F
		Steel	28F-24H 50BL-24H	TFB-7000(2)	T-696
		FRP		TRB-1100(2)	T-696-F
		Steel	28F-24H 50BL-24HR	TFB-7000(2)	T-681
		FRP		TRB-1100(2)	T-681-F
	Steel	28F-24H 50F-24H	TFB-7000(2)	T-681	
	FRP		TRB-1100(2)	T-681-F	

Output (W)	Frequency (kHz)	Ship type	Transducer	Thru-hull pipe	Tank
3k/3k (con't)	28/88	Steel	28BL-12HR 88F-126H	TFB-7000(2)	T-682
		FRP		TRB-1100(2)	T-682-F
		Steel	28F-24H 88F-126H	TFB-7000(2)	T-682
		FRP		TRB-1100(2)	T-682-F
	28/150	Steel	28BL-12HR 150B-12H	TFB-7000(2)	T-683
		FRP		TRB-1100(2)	T-683-F
		Steel	28F-24H 150B-12H	TFB-7000(2)	T-683
		FRP		TRB-1100(2)	T-683-F
	28/200	Steel	28BL-12HR 200B-12H	TFB-7000(2)	T-683
		FRP		TRB-1100(2)	T-683-F
		Steel	28F-24H 200B-12H	TFB-7000(2)	T-683
		FRP		TRB-1100(2)	T-683-F
	38/50	Steel	38BL-15HR 50BL-24HR	TFB-7000(2)	T-681
		FRP		TRB-1100(2)	T-681-F
		Steel	38BL-15HR 50F-24H	TFB-7000(2)	T-681
		FRP		TRB-1100(2)	T-681-F
	38/88	Steel	38BL-15HR 88F-126H	TFB-7000(2)	T-682
		FRP		TRB-1100(2)	T-682-F
	38/150	Steel	38BL-15HR 150B-12H	TFB-7000(2)	T-683
		FRP		TRB-1100(2)	T-683-F
	38/200	Steel	38BL-15HR 200B-12H	TFB-7000(2)	T-683
		FRP		TRB-1100(2)	T-683-F
	50/88	Steel	50BL-24H 88F-126H	TFB-7000(2)	T-697
		FRP		TRB-1100(2)	T-697-F
		Steel	50BL-24HR 88F-126H	TFB-7000(2)	T-682
		FRP		TRB-1100(2)	T-682-F
		Steel	50F-24H 88F-126H	TFB-7000(2)	T-682
		FRP		TRB-1100(2)	T-682-F
50/150	Steel	50BL-24HR 150B-12H	TFB-7000(2)	T-683	
	FRP		TRB-1100(2)	T-683-F	
	Steel	50F-24H 150B-12H	TFB-7000(2)	T-683	
	FRP		TRB-1100(2)	T-683-F	

1. MOUNTING

Output (W)	Frequency (kHz)	Ship type	Transducer	Thru-hull pipe	Tank	
3k/3k (con't)	50/200	Steel	50BL-24H 200B-12H	TFB-7000(2)	T-695	
		FRP		TRB-1100(2)	T-695-F	
		Steel	50BL-24HR 200B-12H	TFB-7000(2)	T-683	
		FRP		TRB-1100(2)	T-683-F	
		Steel	50F-24H 200B-12H	TFB-7000(2)	T-683	
		FRP		TRB-1100(2)	T-683-F	
	68/150	Steel	68F-30H 150B-12H	TFB-7000(2)	T-646	
		FRP		TRB-1100(2)	T-646-F	
	68/200	Steel	68F-30H 200B-12H	TFB-7000(2)	T-646	
		FRP		TRB-1100(2)	T-646-F	
	88/150	Steel	88F-126H 150B-12H	TFB-7000(2)	T-685	
		FRP		TRB-1100(2)	T-685-F	
	88/200	Steel	88F-126H 200B-12H	TFB-7000(2)	T-685	
		FRP		TRB-1100(2)	T-685-F	
	1k	28	Steel	28F-8	TFB-5000(1)	T-604
			FRP		TRB-1000(1)	T-604-F
		50	Steel	50B-6/6B	TFB-5000(1)	T-605
			FRP		TRB-1000(1)	T-605-F
Steel			50B-9B	TFB-5000(1)	T-603	
FRP				TRB-1000(1)	T-603-F	
68		Steel	68F-8H	TFB-5000(1)	T-621	
		FRP		TRB-1000(1)	T-621-F	
88		Steel	88B-8	TFB-5000(1)	T-606	
		FRP		TRB-1000(1)	T-606-F	
200		Steel	200B-5S	TFB-5000(1)	T-605	
		FRP		TRB-1000(1)	T-605-F	
2k		28	Steel	28F-18	TFB-5000(1)	T-612
			FRP		TRB-1000(1)	T-612-F
			Steel	28BL-6HR	TFB-5000(1)	T-702
			FRP		TRB-1000(1)	T-702-F
		38	Steel	38BL-9HR	TFB-5000(1)	T-702
			FRP		TRB-1000(1)	T-702-F

Output (W)	Frequency (kHz)	Ship type	Transducer	Thru-hull pipe	Tank
2k (con't)	50	Steel	50B-12	TFB-5000(1)	T-611
		FRP		TRB-1000(1)	T-611-F
		Steel	50BL-12	TFB-5000(1)	T-702
		FRP		TRB-1000(1)	T-702-F
		Steel	50BL-12HR	TFB-5000(1)	T-702
		FRP		TRB-1000(1)	T-702-F
	82	Steel	82B-35R	TFB-5000(1)	T-609
		FRP		TRB-1000(1)	T-609-F
	88	Steel	88B-10	TFB-5000(1)	T-609
		FRP		TRB-1000(1)	T-609-F
	200	Steel	200B-8/8B	TFB-5000(1)	T-608
		FRP		TRB-1000(1)	T-608-F

1. MOUNTING

Output (W)	Frequency (kHz)	Ship type	Transducer	Thru-hull pipe	Tank
3k	28	Steel	28F-24H	TFB-4000(1)	T-616
		FRP		TRB-1000(1)	T-616-F
		Steel	28BL-12HR	TFB-4000(1)	T-616
		FRP		TRB-1000(1)	T-616-F
	38	Steel	38BL-15HR	TRB-4000(1)	T-616-
		FRP		TRB-1000(1)	T-616-F
	50	Steel	50F-24H	TFB-4000(1)	T-616
		FRP		TRB-1000(1)	T-616-F
		Steel	50BL-24HR	TFB-4000(1)	T-616
		FRP		TRB-1000(1)	T-616-F
		Steel	50BL-24H	TFB-4000(1)	T-694
		FRP		TRB-1000(1)	T-694-F
	68	Steel	68F-30H	TFB-5000(1)	T-614
		FRP		TRB-1000(1)	T-614-F
	88	Steel	88F-126H	TFB-4000(1)	T-618
		FRP		TRB-1000(1)	T-618-F
	107	Steel	100B-10R	TFB-5000(1)	T-609
		FRP		TRB-1000(1)	T-609-F
	150	Steel	150B-12H	TFB-5000(1)	T-615
		FRP		TRB-1000(1)	T-615-F
200	Steel	200B-12H	TFB-5000(1)	T-615	
	FRP		TRB-1000(1)	T-615-F	

1.2 Network Sounder

The network sounder can be installed on a desktop, deck or on a bulkhead. When selecting a mounting location for the network sounder, keep the following in mind:

- The temperature and humidity at the mounting site should be moderate and stable.
- Locate the unit away from exhaust pipes and vents.
- The mounting location should be well ventilated.
- Mount the unit where shock and vibration are minimal.
- Keep the unit away from electromagnetic field-generating equipment such as motors and generators.
- Leave slack in cables for maintenance and servicing ease.

- A magnetic compass will be affected if the network sounder is placed too close to it. Observe the compass safe distances noted in the safety instructions to prevent disturbance to the magnetic compass.

Fasten the network sounder to the mounting location with four self-tapping screws (5x20), referring to the outline drawing at the back of this manual for mounting dimensions.

1.3 Transducer

The performance of the echo sounder largely depends upon the transducer position. Select a place least affected by air bubbles since turbulence blocks the sounding path. Further, select a place least influenced by engine noise. It is known that air bubbles are fewest at the place where the bow first falls and the next wave rises, at usual cruising speed.

Note: The face of the transducer must be facing the sea bottom in normal cruising trim of the boat.

1.4 Optional Speed/Temperature Sensors ST-02MSB, ST-02PSB

1.4.1 Mounting considerations

Select a suitable mounting location considering the following points:

- Select a mid-boat flat position. The sensor does not have to be installed perfectly perpendicular. However, the sensor must not be damaged in dry-docking operation.
- Select a place apart from equipment generating heat.
- Select a place in the forward direction viewing from the drain hole, to allow for circulation of cooling water.
- Select a place free from vibration.
- Do not install near the transducer of an echo sounder, to prevent interference to the echo sounder.

1.4.2 Mounting procedure

1. Dry dock the boat.
2. Make a hole of approx. 51 mm in diameter in the mounting location.
3. Unfasten locknut and remove the sensor section.
4. Apply high-grade sealant to the flange of the sensor.
5. Pass the sensor casing through the hole.
6. Face the notch on the sensor toward boat's bow and tighten the flange.
7. Set the sensor section to the sensor casing and tighten the locknut.
8. Launch the boat and check for water leakage around the sensor.

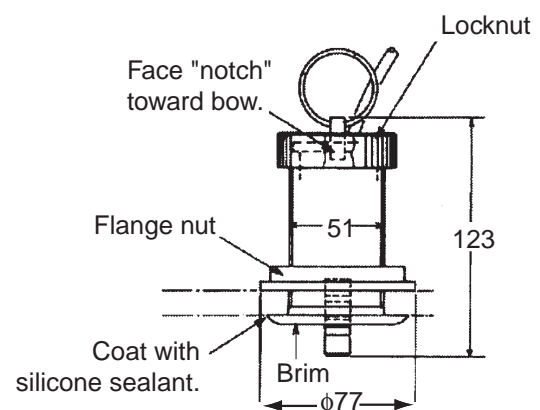

1.5 Optional Temperature Sensors

1.5.1 Transom mount temperature sensor T-02MTB

- Fix the cable at a convenient location with cable clamp.
- When the cable is led in through the transom board, make a hole of approx. 17 mm in diameter to pass the connector. After passing the cable, fill the hole with a sealing compound.

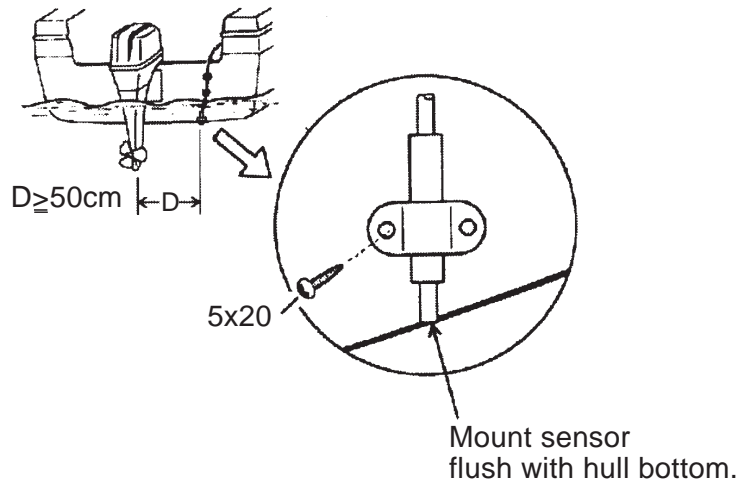

1.5.2 Thru-hull temperature sensor T-02MSB, T-03MSB

Select a suitable mounting location considering the following points:

- Select a mid-boat flat position. The sensor does not have to be installed perfectly perpendicular. However, the location should not be such that the transducer may be damaged when the boat is dry-docked.
- Locate away from equipment which gives off heat.
- Locate away from drain pipes.
- Select a location where vibration is minimal.

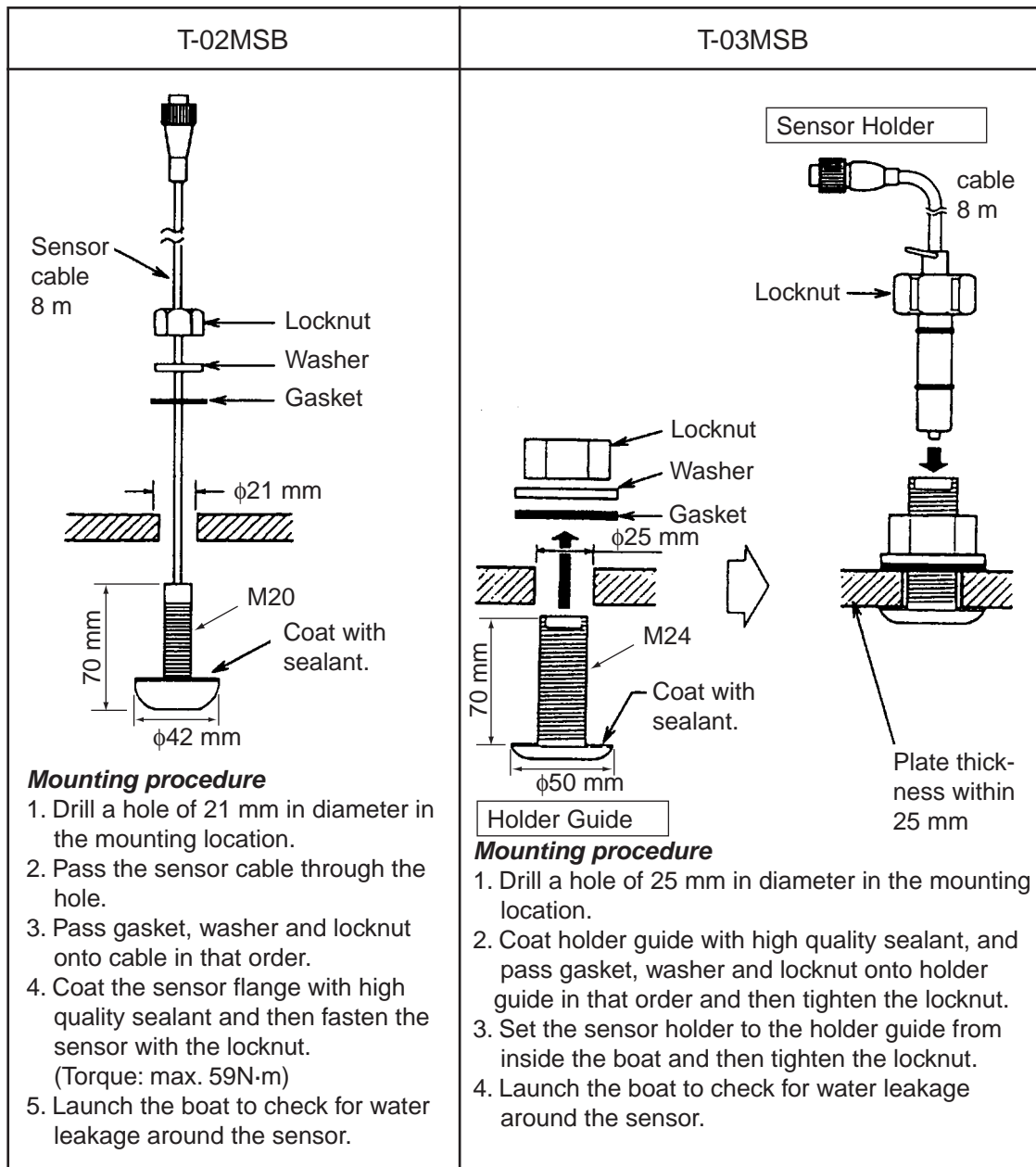

2. WIRING

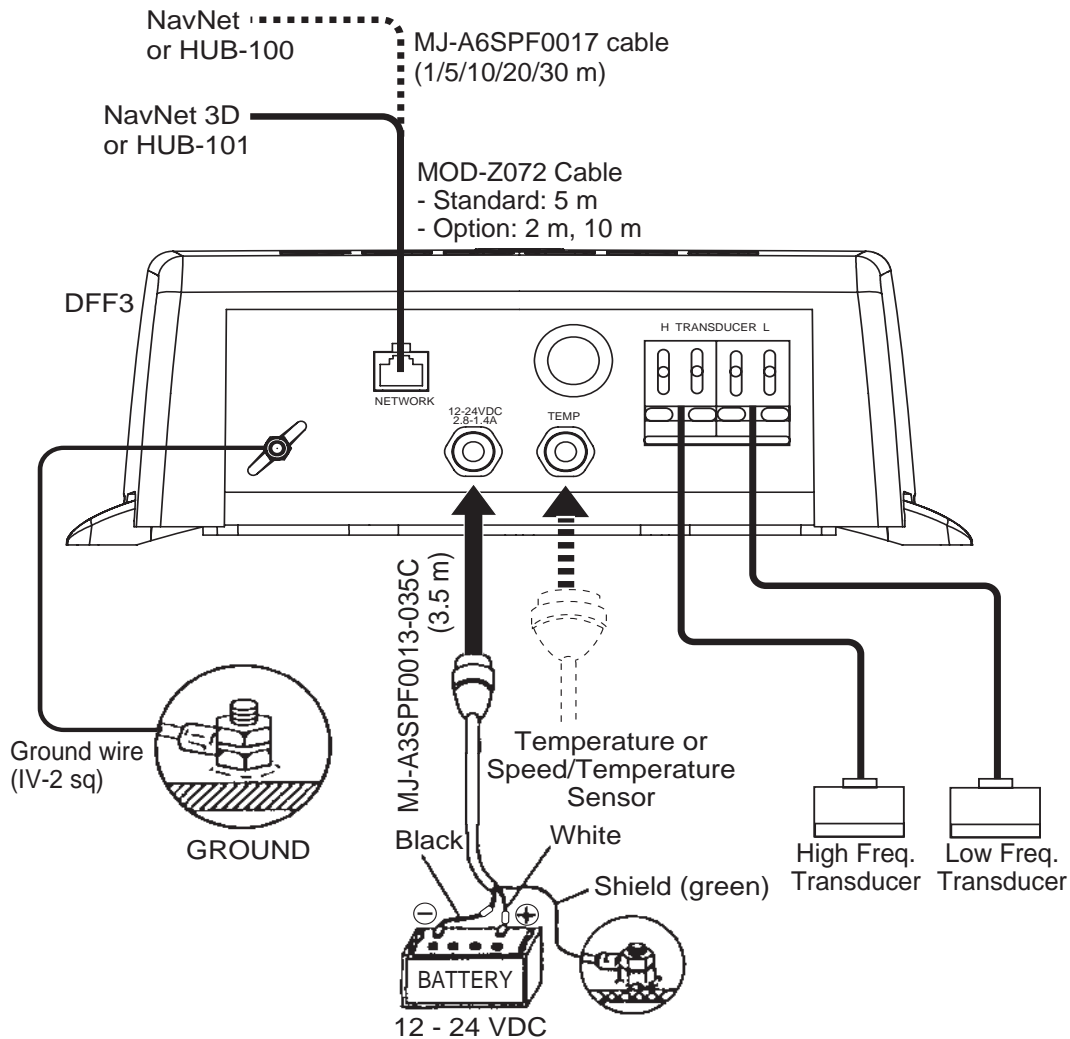

2.1 Wiring Outline

Connect the power cable, transducer cables, sensor cable, network cable and ground wire to their respective locations on the network sounder. See the next page for how to connect the transducer cables.



Ground

Connect a ground wire (IV-2 sq, local supply) between the ground terminal and ship's ground to prevent interference to the sounder picture. Make the length of the wire as short as possible. For FRP vessels, install a ground plate that measures about 20 cm by 30 cm on the outside of the hull bottom and connect the ground wire there.

	CAUTION
	Ground the equipment to prevent mutual interference.

2.2 Transducer Cable

TD-ID transducer (Airmar make transducer)

The TD-ID type transducer can be connected to this equipment. However, note the following limitations:

- TD-ID transducer cannot be used with NavNet, NavNet vx2.
- TD-ID transducer cannot be used with non-TD-ID transducer.
- Connect single TD-ID transducer to low frequency WAGO connector, regardless of actual frequency.

Cable fabrication

Fabricate the transducer cable as shown below. Separate the transducer cable well away from other electric cables to prevent interference to the sounder. This is especially important in the case of power cables from televisions and monitors.

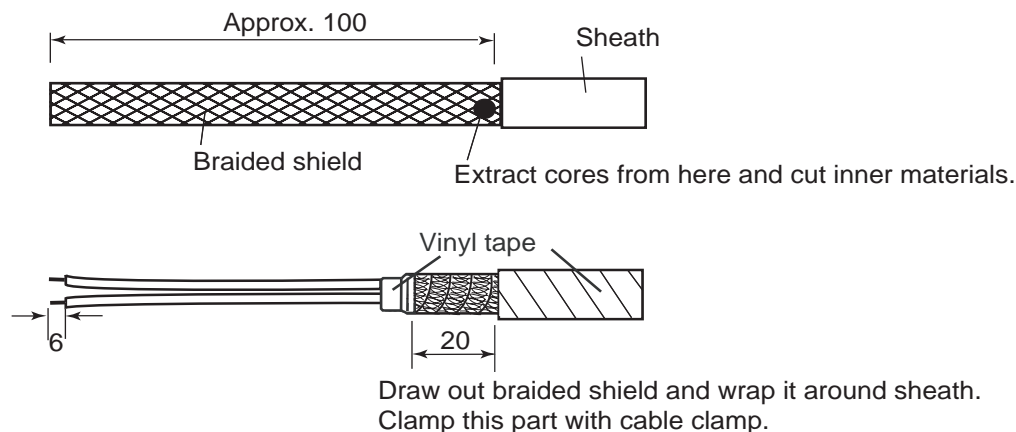

Cable connection

After fabricating the transducer cable, connect the transducer cables to the equipment with WAGO connectors.

1. Open the cover: Grasp the cover at two sides, spread cover slightly and lift.
2. Unfasten six screws to remove the shield cover.
3. Detach the two WAGO connectors (low and high frequency) inside the equipment.

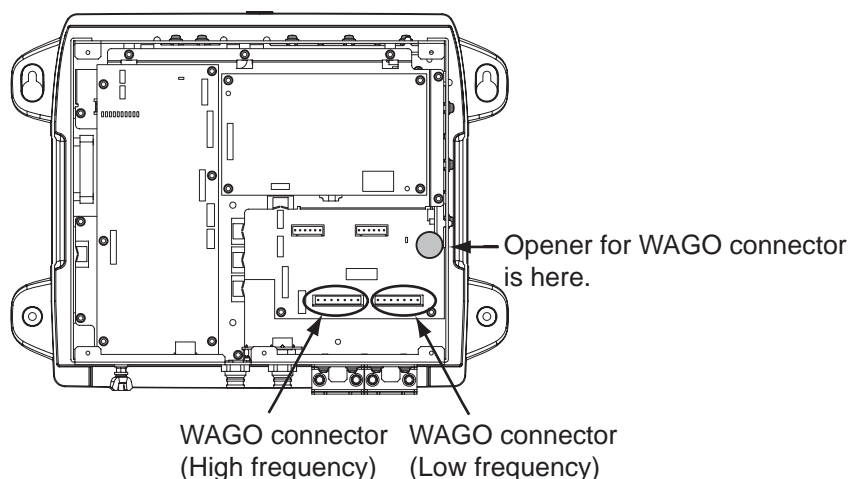

2. WIRING

4. Connect the transducer cable to the WAGO connector, following the instructions in the figure below and the interconnection diagram. (The opener for the WAGO connector is attached inside the equipment. See the figure above.)

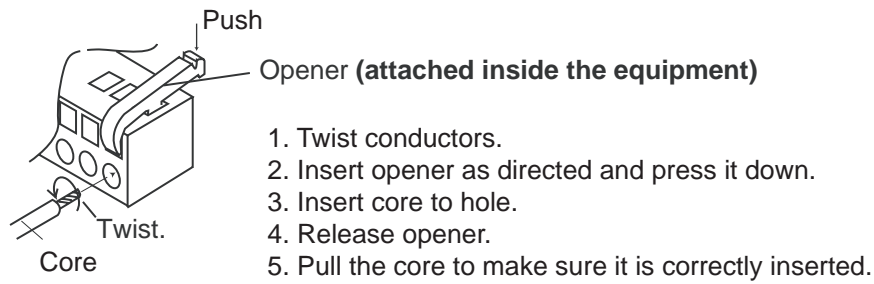

5. Unfasten the two screws labeled Screw A in the figure below.
6. Loosen the two screws labeled Screw B and slide cable clamp upward.

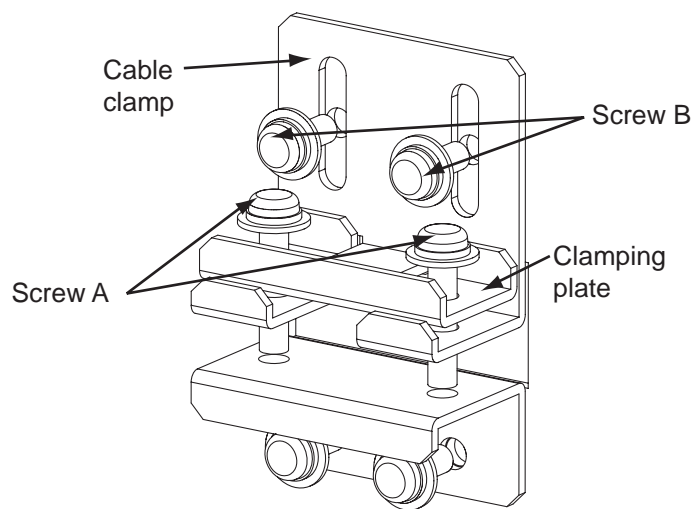

7. Pass the transducer cables through the cable entrance and connect their WAGO connectors to respective terminals inside the equipment.
8. Slide the cable clamp downward and tighten screws B and A in that order to fasten the cable clamp.

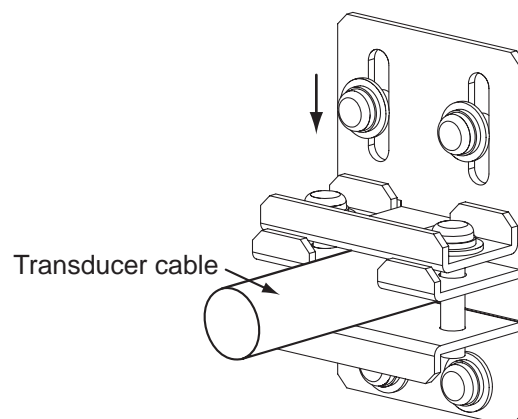

3. INITIAL SETTINGS

⚠ WARNING

Do not open the equipment unless totally familiar with electrical circuits.

Only qualified personnel should work inside the equipment.

3.1 Tap Setting

This equipment is preprogrammed for use with certain transducers. A jumper wire inside the equipment is set according to transducer model. Check the jumper wire setting instructions on the sticker attached to the chassis. Use the opener attached inside the unit to set the jumper wire. One end of the jumper wire is connected to COMMON; connect the other end to A - E in the jumper block as applicable.

For transducers not programmed, for example, Airmar make TD-ID transducer, consult a FURUNO agent or dealer for advice.

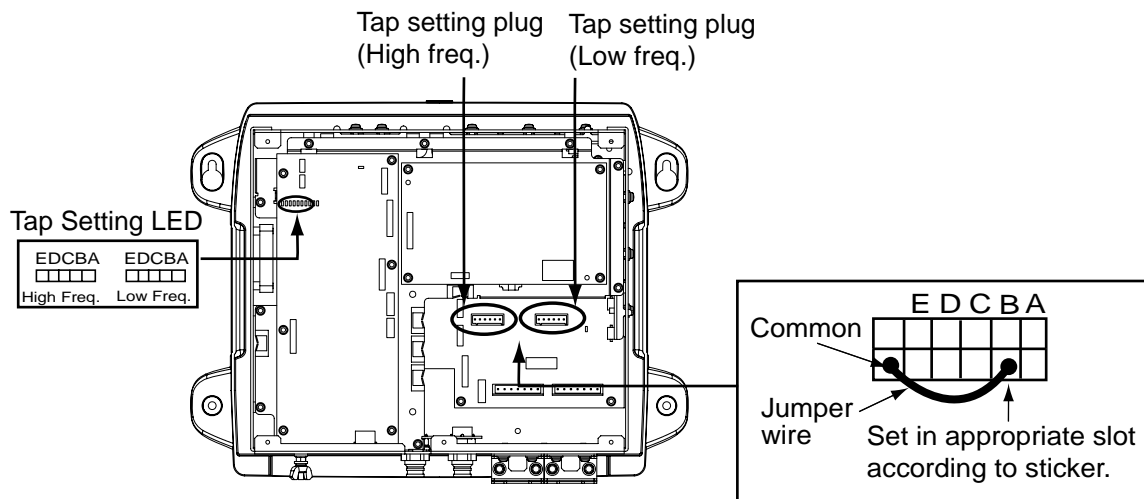

Note 1: For NavNet, the tap settings shown on the NETWORK SOUNDER SETUP are different from actual ones. Therefore, follow the instructions on the sticker inside the equipment.

Note 2: For transducers 50/200-1ST, 50/200-1T and 50/200-12M, use the tap settings for 50/200-1T (50: Tap B, 200: Tap C).

3. INITIAL SETTINGS

3.2 DIP Switch Setting

The DIP switch S2 sets up the system according to the equipment connected. In the default setting all switches (1-8) are OFF. The DIP switch S3 should not be adjusted; leave all switches in the OFF position.

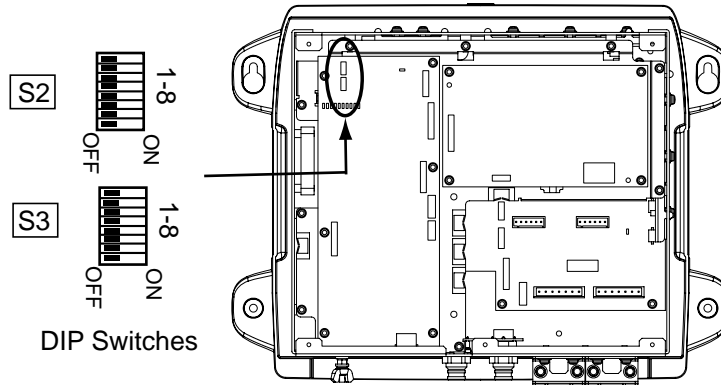

DIP switch S2 description

Switch No.	Function	Setting
1	Power on/off by NavNet or NavNet 3D	OFF: Power sync (for NavNet 3D) ^{*1} ON: No power sync (for NavNet)
2	Automatic/Manual IP address selection	OFF: Automatic IP address assignment. Use this setting for NavNet 3D. ON: Manual IP address assignment. Use this setting for NavNet, and refer to the table on the next page for IP addresses.
3 - 6	Manual IP address assignment	Valid when switch no. 2 is ON. For connection of multiple network sounders, assign each one an IP address with the Mode DIP switch, referring to the table on the next page.
7	Restore default settings (other than LAN and transducer)	See section 4.3.
8	Restore ALL default settings	See section 4.3.

*1: Power sync setting enabled at NavNet 3D.

DIP SW S2 setting, sounder and IP address

SW No.3	SW No.4	SW No.5	SW No.6	Host Name	IP Address
OFF	OFF	OFF	OFF	SOUNDER	172.031.092.001
ON	OFF	OFF	OFF	SOUNDER1	172.031.092.011
OFF	ON	OFF	OFF	SOUNDER2	172.031.092.012
ON	ON	OFF	OFF	SOUNDER3	172.031.092.013
OFF	OFF	ON	OFF	SOUNDER4	172.031.092.014
ON	OFF	ON	OFF	SOUNDER5	172.031.092.015
OFF	ON	ON	OFF	SOUNDER6	172.031.092.016
ON	ON	ON	OFF	SOUNDER7	172.031.092.017
OFF	OFF	OFF	ON	SOUNDER8	172.031.092.018
ON	OFF	OFF	ON	SOUNDER9	172.031.092.019
OFF	ON	OFF	ON		
ON	ON	OFF	ON		
OFF	OFF	ON	ON		
ON	OFF	ON	ON		
OFF	ON	ON	ON		
ON	ON	ON	ON		
ON	ON	ON	ON		

Transducer setting at NavNet/NavNet3D

After setting up the transducer at the DFF3, set transducer type at NavNet, NavNet 3D. See respective Installation Manual for the procedure.

3.3 Operation Check

For NavNet, the DFF3 is powered on/off from ship's switchboard. For NavNet 3D, it is powered on/off from the display unit. The LED on the cover of the DFF3 lights or blinks according to equipment state, as described in the table below.

LED state and meaning

LED state	Meaning
Lighting continuously	<ul style="list-style-type: none"> Standby state. (If, for NavNet, NavNet 3D no signal is received via LAN for more than 10 minutes, the equipment automatically goes into standby to lessen power consumption.) Power on (20 seconds during initialization) IP address not set
Blinking every two seconds	Normal operation
Blinking every 0.4 seconds	Transducer settings at NavNet, NavNet 3D not properly set.

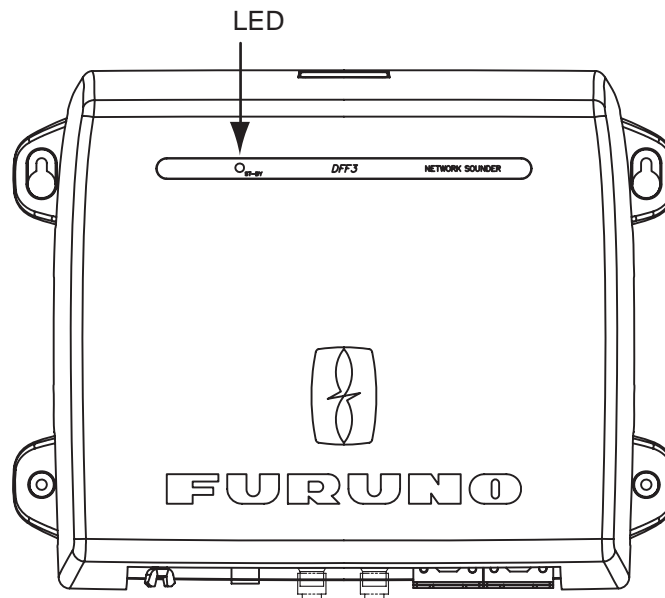

4. MAINTENANCE

⚠ WARNING

ELECTRICAL SHOCK HAZARD
Do not open the equipment.

Only qualified personnel should work inside the equipment.

NOTICE

Do not apply paint, anti-corrosive sealant or contact spray to coating or plastic parts of the equipment.

Those items contain organic solvents that can damage coating and plastic parts, especially plastic connectors.

4.1 Maintenance

Regular maintenance is essential for good performance. Check the items listed in the table below at the suggested interval to help keep your equipment in good shape for years to come.

Item	Check point, action	Check interval
Transducer cables	Check that cables are tightly fastened and are not damaged. Refasten if necessary. Replace if damaged.	Once a month
Power cable, sensor cable	Check that these cables are tightly fastened and not damaged. Refasten if necessary. Replace if damaged.	Once a month
Ground	Check for corrosion. Clean if necessary.	Once a month
Power supply voltage	Check voltage. If out of rating correct problem.	Once a month
Cleaning the network sounder's cabinet	Dust or dirt on the cabinet may be removed with a dry cloth. Do not use chemical-based cleaners to clean the cabinet; they can remove markings and damage the cabinet.	Once a month
Transducer	Marine life on the transducer face will result in a gradual decrease in sensitivity. Check the transducer face for cleanliness each time the boat is dry-docked. Carefully remove any marine life with a piece of wood or fine-grade sandpaper.	When vessel is dry-docked

4.2 Replacing the Fuse

The 5A fuse (Type: FGBO-A 125V 5A PBF, Code No. 000-155-853-10) in the snap-in fuse holder on the power cable protects the equipment from equipment fault and reverse polarity of the ship's mains. If the equipment cannot be powered, the fuse may have blown. Find out the cause for blown fuse before replacing it. If the fuse blows again after replacement, contact a FURUNO agent or dealer for advice.

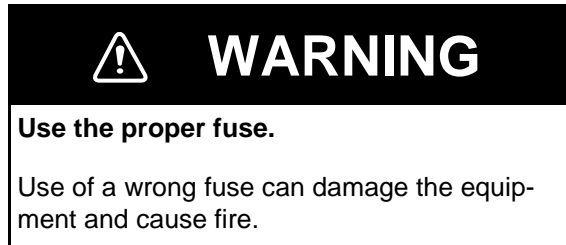

4.3 Restoring Default Settings

This procedure restores all default sounder settings on the NavNet, NavNet 3D. You can restore all default settings or restore those other than transducer and LAN. This procedure should only be performed by a suitably qualified FURUNO technician.



1. Disconnect the power and LAN cables from the DFF3.
2. Turn on the #1 and #2 switches of the Mode switch. See section 3.2 for the location.
3. Turn on the #7 or #8 switch of the Mode switch as applicable.
#7: Restore default settings other than LAN and transducer.
#8: Restore all default settings. Use this when changing transducers.
4. Connect the power cable to the DFF3, and turn on the power at the ship's switchboard.
5. The LED blinks (every four seconds) when default settings are completely restored.

PACKING LIST

02GF-X-9851 -0 1/1

DFF3-J/E

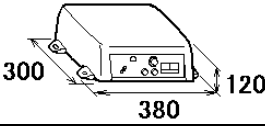
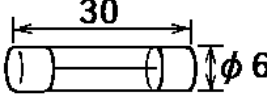
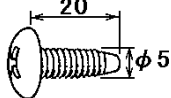
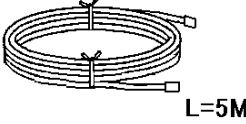
A-1

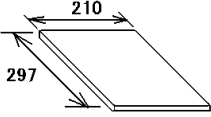
NAME	OUTLINE	DESCRIPTION/CODE No.	Q'TY
ユニット UNIT			
ネットワーク魚探 NETWORK SOUNDER		DFF3 000-011-916-00	1
予備品 SPARE PARTS		SP02-05601	
ヒューズ FUSE GLASS TUBE TYPE		FGB0-A 125V 5A PBF 000-155-853-10	2
工事材料 INSTALLATION MATERIALS		CP02-08500	
+トラスタッピングネジ 1シュ SELF-TAPPING SCREW		5X20 SUS304 000-162-608-10	4
ケーブル(組品)LAN CABLE ASSY.		MOD-Z072-050+ 000-167-176-10	1
ケーブル組品MJ CABLE ASSY.		MJ-A3SPF0013-035C (5A) 000-157-939-10	1
図書 DOCUMENT			
取扱説明書 OPERATOR'S MANUAL		OM*-20370-* 000-168-581-1* **	1

コード番号末尾の[**]は、選択品の代表コードを表します。

CODE NUMBER ENDING WITH "**" INDICATES THE CODE NUMBER OF REPRESENTATIVE MATERIAL.

型式/コード番号が2段の場合、下段より上段に代わる過渡期品であり、どちらかが入っています。なお、品質は変わりません。

TWO TYPES AND CODES MAY BE LISTED FOR AN ITEM. THE LOWER PRODUCT MAY BE SHIPPED IN PLACE OF THE UPPER PRODUCT. QUALITY IS THE SAME.

(略図の寸法は、参考値です。DIMENSIONS IN DRAWING FOR REFERENCE ONLY.)

C2037-Z01-A

**SPECIFICATIONS OF NETWORK SOUNDER
DFF3**

1 GENERAL

- 1.1 TX frequency 28-200 kHz, two frequencies alternately transmitted (selectable)
- 1.2 Output power 1/2/3 kW nominal
- 1.3 Amplifier type Wide dynamic range linear amplifier (double superheterodyne)
- 1.4 Depth range and Pulse repetition rate (PRR)

200 kHz, TX rate: 20

Range (m)	PRR (/min.)
2	2403 (max)
5	2403
10	1621
40	476
100	222
200	117
400	58
1200	34

2 INTERFACE

- 2.1 Number of port LAN: 1 port, Transducer: 2 port, Temp/speed sensor: 1 port
- 2.2 Network Ethernet 10BASE-T/100BASE-TX

3 POWER SUPPLY

- 3.1 Network sounder 12-24 VDC: 2.8-1.4 A
- 3.2 Rectifier (PR-62, option) 100/110/220/230 VAC, 1 phase, 50/60 Hz

4 ENVIRONMENTAL CONDITION

- 4.1 Ambient temperature -15°C to +55°C
- 4.2 Relative humidity 93% at 40°C
- 4.3 Degree of protection IP20
- 4.4 Vibration requirement IEC 60945

5 COATING COLOR

N2.5 (not changed)

表1 TABLE 1

寸法区分 (mm) DIMENSION	公差 (mm) TOLERANCE
$L \leq 50$	± 1.5
$50 < L \leq 100$	± 2.5
$100 < L \leq 500$	± 3

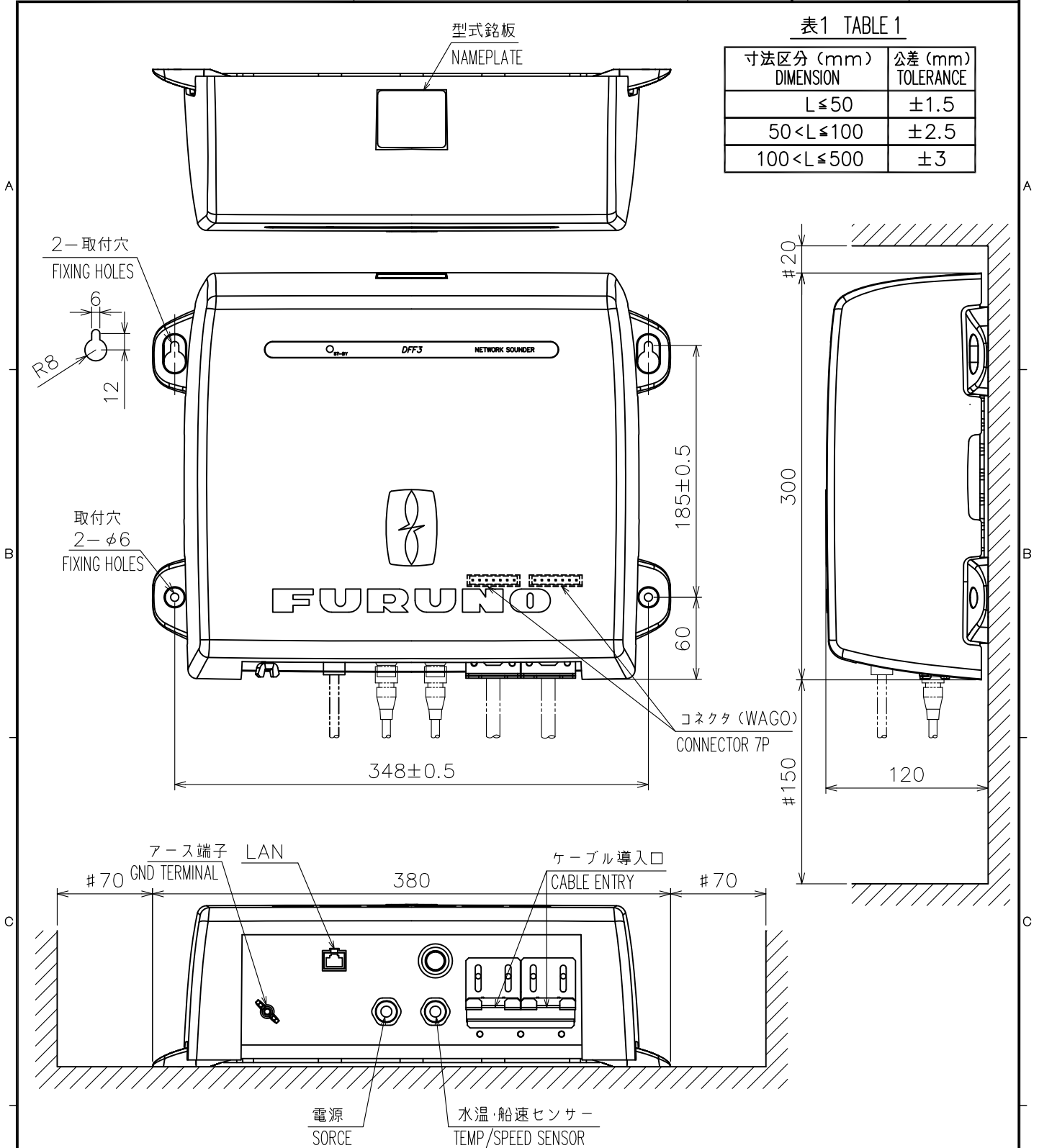

- 注 記
- 1) #印寸法は最小サービス空間寸法とする。
 - 2) 指定外の寸法公差は表1による。
 - 3) 取付用ネジはトラスタッピンネジ呼び径5×20を使用のこと。
- NOTE
1. # MINIMUM SERVICE CLEARANCE.
 2. TABLE 1 INDICATES TOLERANCE OF DIMENSIONS WHICH IS NOT SPECIFIED.
 3. USE TAPPING SCREWS 5x20 FOR FIXING THE UNIT.

DRAWN	Jan. 17 '08 T.YAMASAKI	TITLE	DFF3
CHECKED	Jan. 18 '08 T.TAKENO	名称	ネットワーク魚探
APPROVED	Jan. 18 '08 R.Esumi		外寸図
SCALE	1/4 MASS 3.9 $\pm 10\%$ kg	NAME	NETWORK SOUNDER
DWG.No.	C2037-G01-A	REF.No.	02-161-100G-1
		OUTLINE DRAWING	

ECF

(Elemental Chlorine Free)

The paper used in this manual
is elemental chlorine free.

FURUNO ELECTRIC CO., LTD.

9-52 Ashihara-cho,
Nishinomiya, 662-8580, JAPAN

Telephone : +81-(0) 798-65-2111

Fax : +81-(0) 798-65-4200

• FURUNO Authorized Distributor/Dealer

All rights reserved. Printed in Japan

A : MAR. 2008

Pub. No. OME-20370-A

(DAMI) DFF3



* 0 0 0 1 6 8 5 8 2 1 0 *